

# Modern Steel Construction

March 2024



**NASCC:  
THE STEEL CONFERENCE  
EXHIBITOR LIST  
INSIDE!**



# 2 MINUTES 18 SECONDS

W18 × 35 × 12' SPEEDRUN

- 1 COPE
- 1 FLANGE THIN
- 2 WELD PREPS
- 2 RAT HOLES
- 8 DRILLED HOLES
- 22 SCRIBES

**WATCH  
HERE**



**THE  
PEDDISUBX-1120**

**Peddinghaus**

**STRONGER** THAN  
**STEEL**®

www.peddinghaus.com | info@peddinghaus.com | (815) 937-3800



# NASCC: THE STEEL CONFERENCE

HENRY B. GONZALEZ CONVENTION CENTER  
SAN ANTONIO

MARCH 20–22, 2024

[aisc.org/nascc](http://aisc.org/nascc)



# THANK YOU TO OUR SPONSORS!

## CONFERENCE DINNER

# Nucor

## WELCOME LOUNGE

# Autodesk, Inc.

## GOLD

Atlas Tube,  
A Zekelman Company  
CADeploy, Inc.  
Controlled Automation  
MOLD-TEK  
Technologies, Inc.  
SDS2 by ALLPLAN

## SILVER

Canam | CSC – Canam Steel Corp.  
Greenbrook Engineering Services  
IDEA StatiCa US LLC  
IRyS Global, Inc. | JMT Consultants, Inc.  
Peddinghaus Corporation  
Sherwin-Williams Protective & Marine

## BRONZE

Applied Bolting Technology, Inc.  
Bull Moose Tube Company  
Chicago Metal Rolled Products  
Diligent | Gerdau | Hercules Bolt Company  
Infra-Metals Co. | Taylor Devices, Inc.  
Team Detailing Solutions LLC  
Terracon Consultants, Inc.

## ELEVATE

A.C.T. Metal Deck Supply  
Bendco Houston Pipe Benders  
Cast Connex Corporation  
Cohen Seglias Pallas Greenhall & Furman, PC  
Degenkolb Engineers + Ruby & Associates,  
A Degenkolb Company | Exact Detailing, Ltd.  
GWY, LLC | Ironworkers/IMPACT | Linq LLC  
Steel Plus Network | Taylor Devices, Inc.  
W&W | AFCO Steel

# Modern Steel Construction

March 2024

## in every issue

### departments

- 6 EDITOR'S NOTE
- 9 STEEL INTERCHANGE
- 12 STEEL QUIZ
- 84 NEW PRODUCTS
- 86 NEWS & EVENTS
- 90 STRUCTURALLY SOUND

### resources

- 88 ADVERTISER INDEX
- 89 MARKETPLACE & EMPLOYMENT

## columns

### steelwise

#### 16 Stay Stable

BY BO DOWSWELL, PE, PHD

Beam stability in industrial structures requires careful consideration of unique conditions during the design process.

### field notes

#### 23 Bridge Authority

INTERVIEW BY GEOFF WEISENBERGER

Rob Connor has helped make Purdue University a leader in steel bridge research.

### business issues

#### 26 The Significance of Soft Skills

BY ERIN CONAWAY, PE

Four engineers concur that non-technical acumen was crucial in their rise to leadership positions.



flydenver.com

44

## features

#### 30 Fork in the Road

BY KEVIN DAMRON, PE, ADAM DEMARGEL, JOHN MICHAEL JOHNSON, AND BRAD ROBSON, PE

Environmental constraints prompted mid-project design changes to a new steel bridge in Kentucky.

#### 38 Banking on Steel

BY PAUL CONSTANTINI, SE, PE, GREG MARTIN, PE, AND MARY STANZIONE, PE

Installing a larger video board at Philadelphia's Citizens Bank Park required extensive research on the existing support structure before any construction began.

#### 44 Airport Overhaul

BY CHRIS ADAMS, PE, ISABELA GONZALEZ, PE, RICHARD HAIGHT, AND THOMAS LUTZA

A balcony extension and frame conversion were the greatest challenges in remodeling Denver International Airport's Great Hall.

### conference preview

#### 51 Special Steel

BY JAMES PAWLIKOWSKI, SE

Hybrid structural systems can create a striking visual, but only if a meticulous and layered design process is done well.

### conference preview

#### 52 A Nonconformance Walks Into a CAR

BY TIM DUKE

Through the nonconformance and corrective action process, an effective quality management system can acknowledge, address, and correct internal missteps as easily as outside ones.

### conference preview

#### 55 NASCC: THE STEEL CONFERENCE 2024 Exhibitor List

**ON THE COVER:** A new bridge in Kentucky is the final link in a key Appalachian highway corridor, p. 30. (Photo: Chris Poynter, Stupp Bridge)

MODERN STEEL CONSTRUCTION (Volume 64, Number 3) ISSN (print) 0026-8445; ISSN (online) 1945-0737. Published monthly by the American Institute of Steel Construction (AISC), 130 E Randolph Street, Suite 2000, Chicago, IL 60601. Single issues \$8.00; 1 year, \$60. Periodicals postage paid at Chicago, IL and at additional mailing offices. Postmaster: Please send address changes to MODERN STEEL CONSTRUCTION, 130 E Randolph Street, Suite 2000, Chicago, IL 60601.

**DISCLAIMER:** AISC does not approve, disapprove, or guarantee the validity or accuracy of any data, claim, or opinion appearing under a byline or obtained or quoted from an acknowledged source. Opinions are those of the writers and AISC is not responsible for any statement made or opinions expressed in MODERN STEEL CONSTRUCTION. All rights reserved. Materials may not be reproduced without written permission, except for noncommercial educational purposes where fewer than 25 photocopies are being reproduced. The AISC and Modern Steel logos are registered trademarks of AISC.



Printed on paper made from a minimum of 10% recycled content.



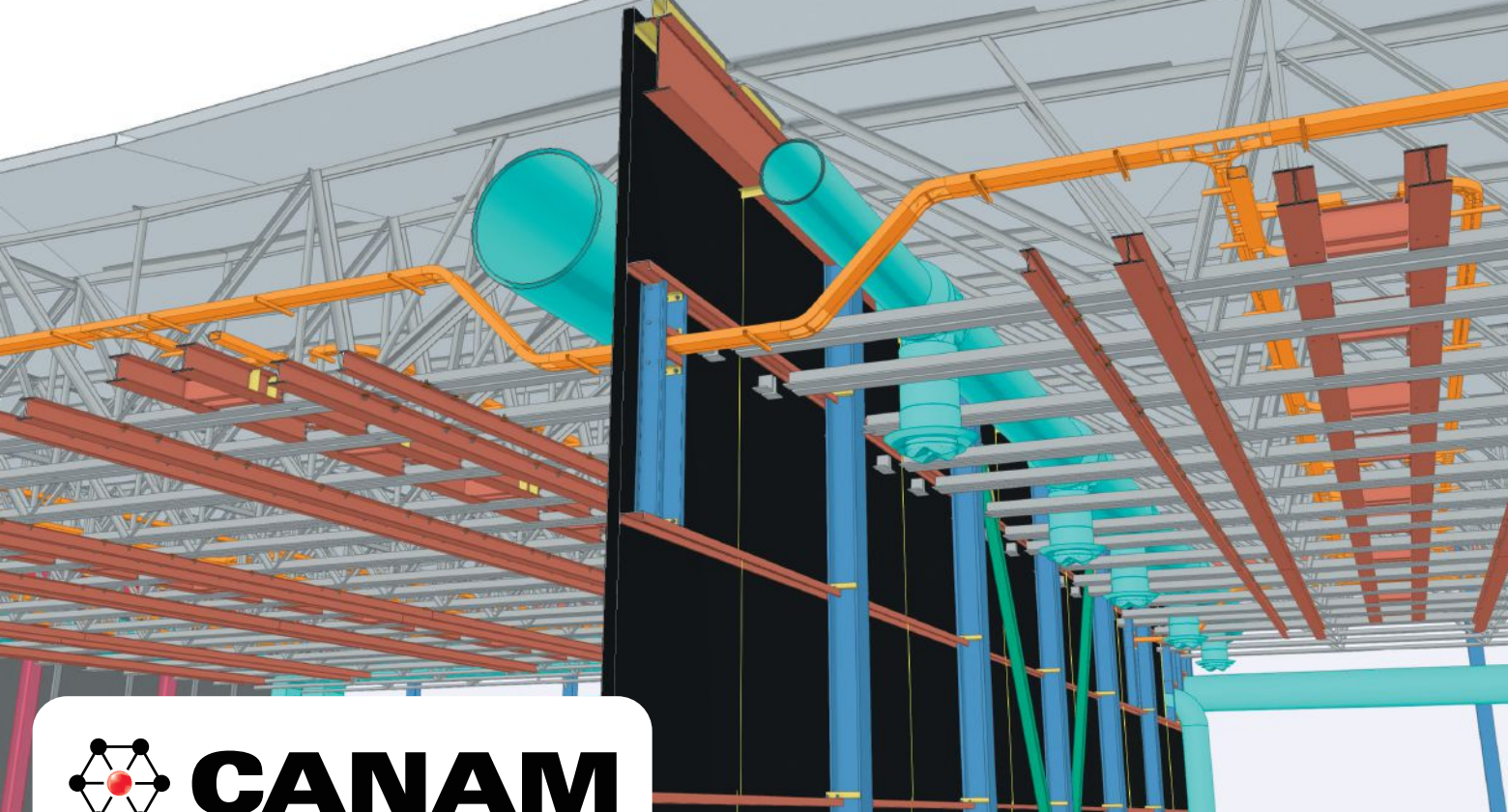

# CANAM

## Bringing you peace of mind with BIM

At Canam, we don't just bring over 60 years of expertise and deliver more than 300,000 projects, we are driven by a passion to exceed your expectations. With a dedicated team of 100+ engineers and 650+ detailers, we're not just a supplier, we're your ultimate partner for success.

Choose Canam for cutting-edge tools, inclusive support, tailored solutions, unwavering assistance, and streamlined collaboration. Elevate your collaboration and exchange with state-of-the-art technology.

Ready to elevate your steel construction projects to new heights?

Partner with Canam's dedicated BIM team and experience the difference!



Meet us at NASCC Booth #1323

[canam.com](http://canam.com)



## editor's note



Sadly, the answer, as is the case with most of our trips back to Colorado for the holidays in recent years, is no.

We used to live in Colorado (we've been in Chicago since 2002) and hit the slopes quite a bit back in the days before kids and a mortgage. Lift tickets were expensive then, and they haven't gotten cheaper. Traffic to the ski resorts was bad then, and it *definitely* hasn't gotten any better. With all the chaos of the holidays and trying to fit in visits with family and friends, skiing just became less of a priority. (And for the record, I wish people would ask if I snowboarded instead, since that's my preferred method of getting down the mountain. But alas).

That said, we took a short trip to the mountains on this visit. We headed up to Winter Park to go tubing—the kind where you ride inner tubes down a hill like a sled. The first place we tried was so crowded and expensive that we decided to head further down the road to a place my wife and her brother went as kids. For the same price as the other spot, you got four hours instead of one, and ice skating was included.

The skating is worth mentioning because, 1) I grew up in Texas and had ice skated exactly once in my life before this trip (almost 30 years ago, and it didn't go well), 2) I made a last-second decision to face my fear, put on a pair of skates, and venture onto the rink, and 3) miraculously, I didn't fall! I was no Kristi Yamaguchi, but I got around the rink a few times, built up some confidence, and actually left wanting to try it again sometime. Overall, we had a blast for a relative bargain.

What else is a relative bargain (and a blast as far as trade shows go)? NASCC: The Steel Conference. For one low price, you gain access to more than 250 sessions

We went to Colorado for the holidays, and whenever you tell people you went to Colorado in the winter, the first question they ask, almost invariably, is, "Did you ski?"

of must-have practical information you can implement as soon as you get home, an exhibit hall packed with more than 300 innovations you need to know about right now, and a chance to network with thousands of the world's best designers, fabricators, erectors, and other steel fans.

You can also attend several engaging keynote sessions. Some of this year's speakers are expert Chad Hymas, who will offer advice on how to build an environment where everyone has safety on their minds; Northeastern University professor Jerome F. Hajjar, PE, PhD, who will take a deep dive into one of the hottest topics in the design and construction industry during his presentation "The Stability of Resilient and Sustainable Structures"; David Odeh, SE, PE, who will share his thoughts on the upcoming film *Cities of the Future: Reimagining Our World* during a screening of the film's trailer; and Benjamin W. Schafer, PE, PhD, the 2024 T.R. Higgins Lectureship Award winner and the Hackerman Professor of Civil and Systems Engineering at Johns Hopkins University, whose presentation "Think Global, Buckle Local: Exploring Local Buckling in Structural Steel" will focus on the role of local plate buckling in the global behavior of structural steel members.

This year's show takes place in San Antonio, Texas, from March 20–22. You can register now at [aisc.org/nascc](https://aisc.org/nascc). There will be plenty of opportunities to learn new things or learn new ways to do old things—just like I did with ice skating.

  
Geoff Weisenberger  
Editor and Publisher

# Modern Steel Construction

## Editorial Offices

130 E Randolph St, Ste 2000  
Chicago, IL 60601  
312.670.2400

## Editorial Contacts

EDITOR AND PUBLISHER

Geoff Weisenberger  
312.493.7694  
weisenberger@aisc.org

ASSOCIATE EDITOR

Patrick Engel  
312.550.9652  
engel@aisc.org

SENIOR DIRECTOR OF PUBLICATIONS

Keith A. Grubb, SE, PE  
312.804.0813  
grubb@aisc.org

GRAPHIC DESIGN MANAGER

Kristin Hall  
773.636.8543  
hall@aisc.org

EDITORIAL DIRECTOR

Scott Melnick  
312.804.1535  
melnick@aisc.org

## AISC Officers

CHAIR

Hugh J. McCaffrey  
Southern New Jersey Steel Co.

VICE CHAIR

Glenn R. Tabolt, PE  
STS Steel, Inc.

SECRETARY/LEGAL COUNSEL

Edward Seglias, Cohen Seglias  
Pallas Greenhall & Furman, PC

PRESIDENT

Charles J. Carter, SE, PE, PhD

SENIOR VICE PRESIDENTS

Scott Melnick  
Mark W. Trimble, PE

VICE PRESIDENTS

Todd Alwood  
Carly Hurd  
Mike Mospan  
Christopher H. Raebel, SE, PE, PhD  
Brian Raff

## Editorial Advisory Panel

Brandon Chavel, PE, PhD  
Michael Baker International

Nat Killpatrick  
Basden Steel

Christina McCoy, SE  
Oklahoma State University  
School of Architecture

Allison Shenberger, PE  
ruby+associates

Justin Smith, PE  
Dekker Perich Sabatini

## Advertising Sales

Geoff Weisenberger  
312.493.7694  
weisenberger@aisc.org

## Address Changes and Subscription Concerns

312.670.2401  
subscriptions@aisc.org

## Reprints

Kristin Hall  
hall@aisc.org





**SDS2**  
BY ALLPLAN

# The details are automatic.

When it comes to steel detailing, automating the little things makes a big difference. Trust SDS2 to handle some of your most repetitive and time-consuming detailing tasks to save you time, improve your accuracy, and let you focus on more important things. Like winning bigger projects, perfecting your workflows—and taking vacation.

## **AUTOMATE MORE**

- Structural modeling
- Stairs and rails
- Connections
- Detailing and shop drawings
- Piecemarking
- Clash detection
- Material takeoffs
- CNC exports
- Revisions

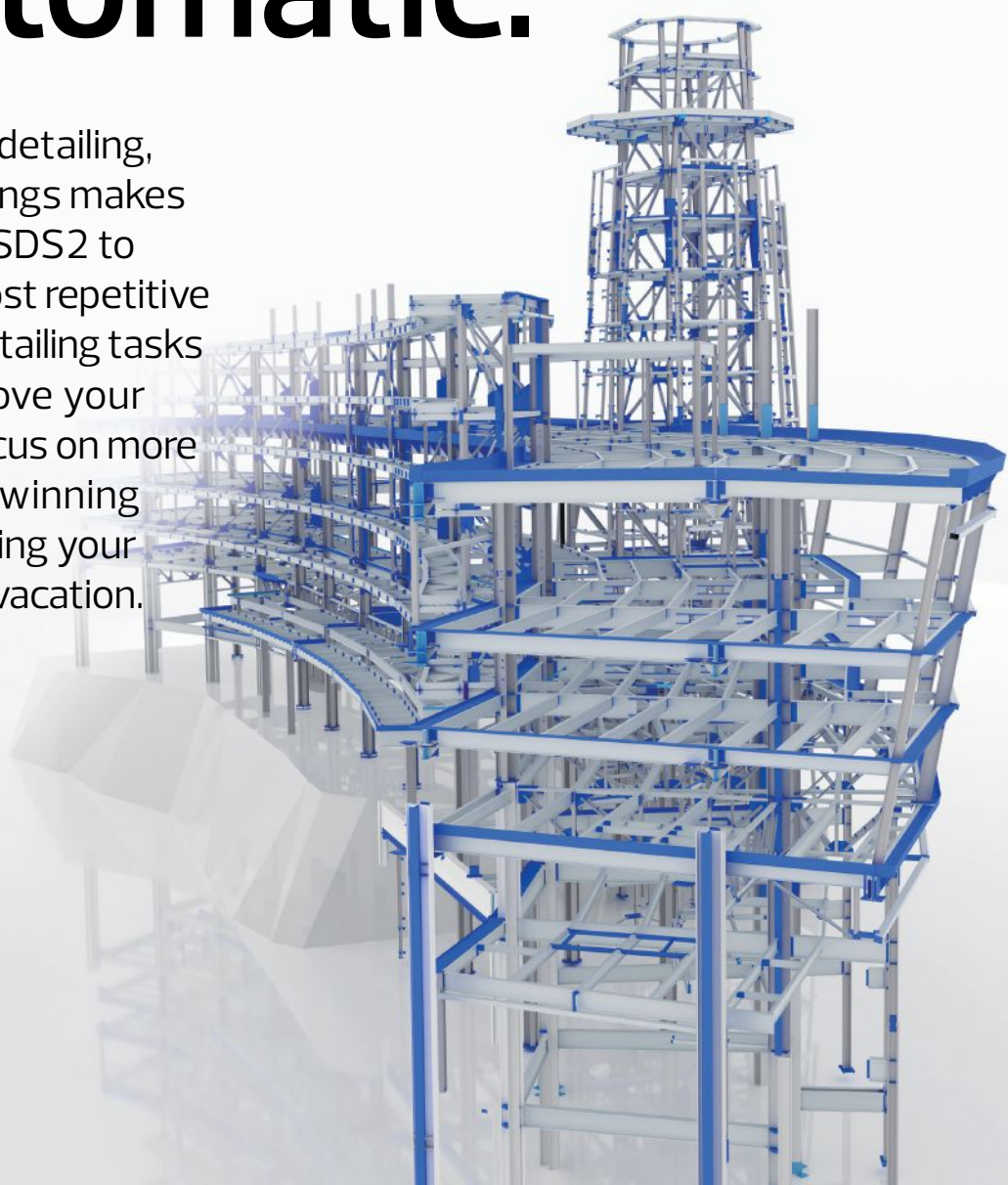

**FIND US AT NASCC BOOTH 915**

Model by Mold-Tek Technologies \ Gillette Stadium North Endzone Renovation

sds2.com

**SEE IT FOR YOURSELF**  
REQUEST A DEMO TODAY







You support this



Madness?



**easy.iesweb.com**

Victory is not optional for engineers. Get the results you need with IES tools.



# steel interchange

---

If you've ever asked yourself "Why?" about something related to structural steel design or construction, *Modern Steel's* monthly Steel Interchange is for you!

Send your questions or comments to [solutions@aisc.org](mailto:solutions@aisc.org).

## Space Rocket Loading

**I'm working on a project where I'm designing a storage building adjacent to a launch pad for a space rocket. Our client is anticipating a certain pressure to be applied to the storage building. We are planning on using steel framing for the gravity and lateral systems. Does AISC provide any guidance on this kind of building design?**

Rocket launch facilities are highly specialized, and there are no publications developed by AISC (or any other publisher that I am aware of) that discuss the design of these structures. Structures in the blast zone are subjected to high pressures and temperatures. The owner should provide pressure and temperature maps for launch conditions. These are specific to the rocket and have been developed for past structures based on computer models, empirical measurements and/or judgment.

For the subjected to high pressures, the structures can often be similar to ships, with steel plate decks stiffened by closely spaced rolled shapes or plates. For any areas that are subjected to more moderate temperatures and pressures, the framing can be designed similar to any other industrial structure, but with smaller girt/purlin spacings and stronger siding/roofing panels.

You may be interested Mission to Mars—Construction of the ML2 Mobile Launch Tower, a session at 2024 NASCC: The Steel Conference March 20–22 in San Antonio, Texas.

*Bo Dowsnell, PE, PhD*

## Slotted-Holes in Single-Plate Connections

**When using Table 10-9 in the 16th Edition *Steel Construction Manual*, the section titled Dimensional Limitations states, "Standard holes (STD) or short-slotted holes transverse to the direction of the supported member reaction (SSLT) are permitted to be used as noted in Table 10-9." *Specification for Structural Steel Buildings* (ANSI/AISC 360-22) Section J3.3 states that bolted connections may have short-slotted holes in both plies. Would this permit the use of short-slotted holes in the single-plate and in the beam web to gain additional erection tolerances?**

The intent of the procedures in Part 10 of the *Manual* for single-plate shear connections is that there would only be a short slot in one element—the single plate.

One reason for this is the design of the eccentrically loaded bolt group. It's common to use *Manual* Tables 7-6 through 7-13 to determine the strength of eccentrically loaded bolt groups. The underlying procedure, the instantaneous center of rotation method described in the *Manual*, assumes load-deformation behavior based on bolts in standard holes.

The C-values from the *Manual* tables can be justified when there is a short slot in one element. The C-values from the *Manual* tables cannot be justified when there is a long slot. The use of short slots in both plies results in a condition like long slots, and therefore, a condition for which the C-values from the *Manual* tables cannot be justified.

Chapter J does permit short slots in both plies, so one could theoretically design a single-plate shear connection with short slots in both plies that satisfies the requirements of the *Specification*, but this would have to be done using some method other than that described in Part 10 of the *Manual*.

*Larry Muir, PE*

## Corner Clip Dimensions

**What dimensions are typically used for the corner clips of stiffeners and continuity plates attached to the flanges and webs of rolled members?**

Many U.S. fabricators primarily use 3/4-in. (19 mm) corner clips. They will use 1-in. (25 mm) corner clips where the 3/4-in. corner clips prove to be too small. Corner clips are commonly configured as a 45° cut. Part 8 of the *Manual* states, "Corners of stiffeners and similar elements that fit into a corner should be clipped generously to avoid the lack of fusion that would likely result in that corner. In general, a 3/4-in. clip will be adequate, although this dimension can be adjusted to suit conditions, such as when the fillet radius is larger or smaller than that for which a 3/4-in. clip is appropriate."

For seismic applications (specifically for connections and joints that are part of the Seismic Force Resisting System), Section D2.4 in *AISC Seismic Provisions for Structural Steel Buildings* states, "The design of continuity plates and stiffeners located in the webs of rolled shapes shall allow for the reduced contact lengths to the member flanges and web based on the corner clip sizes in Section I2.4."

Section I2.4 states, "Corner of continuity plates and stiffeners placed in the webs of rolled shapes shall be detailed in accordance with AWS D1.8/D1.8M, clause 4.1." AWS D1.8 requires a minimum 1/2-in. (12 mm) radius. Clause 4.1 of AWS D1.8 provides other requirements that must be satisfied.

---

All mentioned AISC publications, unless noted otherwise, refer to the current version and are available at [aisc.org/publications](http://aisc.org/publications). *Modern Steel* articles can be found at [www.modernsteel.com](http://www.modernsteel.com).



# steel interchange

The commentary provided for the *Provisions* explains, “The available lengths for welds of continuity plates and stiffeners to the web and flanges of rolled shapes are reduced by the detailing requirements of AWS D1.8/D1.8M, clause 4.1 (AWS, 2021), as specified in Section I2.4 of the *Provisions*. See Figures C-D2.3(a) and (b). These large corner clips are necessary to avoid welding into the *k*-area of wide-flange shapes.”

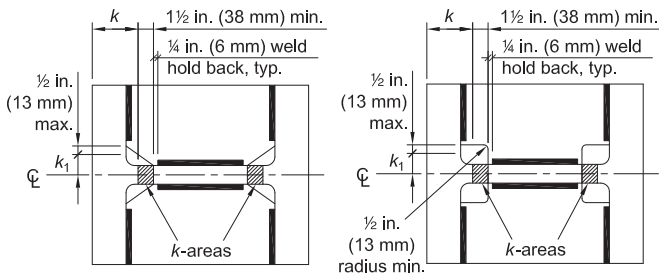

a. Straight corner clip                      b. Curved corner clip  
Fig. C-D2.3. Configuration of continuity plates.

Larry Muir, PE

## Change in $t_p$ equation in AISC Design Guide 39

In Design Guide 16: *Flush and Extended Multiple-Row Moment End-Plate Connections*,  $\gamma_r$  is located in the numerator for the  $t_{p,reqd}$  calculation, yet in Design Guide 39: *End-Plate Moment Connections* it is in the denominator. Why has this changed?

$$t_{p,reqd} = \sqrt{\frac{(1.11)\gamma_r \phi M_{pp}}{\phi_b F_{py} Y}} \quad (2-7)$$

$$t_{p,reqd} = \sqrt{\frac{M_u}{\gamma_r \phi_b F_{py} Y_p}} \quad (5-5a)$$

This change better reflects the fact that  $\gamma_r$  is a reduction of the flexural strength so that the flush end-plate connections remain fully rigid. In Design Guide 39, Eq. 5-1, you will find that  $\gamma_r$  is now either 0.80 for flush end-plate configurations or 1.0 for extended end-plate configurations, whereas it was previously defined as 1.25 for flush end-plate configurations or 1.0 for extended end-plate configurations in Design Guide 16. The following excerpt from Design Guide 39 Section 3.2 gives the basis for the  $\gamma_r$  factor and notes the equivalence of multiplying by 0.80 in Design Guide 39 to dividing by 1.25 in Design Guide 16:

Michael Desch ([desch@aisc.org](mailto:desch@aisc.org)) is a staff engineer in AISC’s Steel Solutions Center. Bo Dowswell, principal with ARC International, LLC, and Larry Muir are consultants to AISC.

Steel Interchange is a forum to exchange useful and practical professional ideas and information on all phases of steel building and bridge construction. Contact Steel Interchange with questions or responses via AISC’s Steel Solutions Center: 866.ASK.AISC | [solutions@aisc.org](mailto:solutions@aisc.org). The complete collection of Steel Interchange questions and answers is available online at [www.modernsteel.com](http://www.modernsteel.com).

“To determine whether end-plate moment connections are FR [fully restrained] or PR [partially restrained] type connections, it is necessary to analyze their stiffness. Hendrick et al. (1985) evaluated the stiffness of approximately 20 flush end-plate connections and found that the moment-rotation curves crossed the beam line at an average of 83% of the values required to be considered FR.

“Another way to look at this result is that the connections were stiff enough to be considered FR up to a moment equal to 83% of the end-plate flexural strength. Hendrick et al., therefore, recommended that the end-plate design flexural strength be reduced by 0.80 (slightly reduced from 83% because of variability in results) so the connection would behave as FR when subjected to factored loads.

“This shows up in the end-plate design procedures as a reduction factor of  $\gamma_r = 0.80$  applied to the flexural strength associated with end-plate flexural yielding for flush end-plate connections. It is noted that this reduction factor is equivalent to dividing by 1.25, which was used in the previous edition of this Design Guide.”

Michael Desch, PhD

## Compression Ring Design

Does AISC provide guidance on how to design a curved member compression ring?

Curved members can be designed according to AISC Design Guide 33: *Curved Member Design*, which can be downloaded from the AISC website at [aisc.org/dg](http://aisc.org/dg). Chapter 6 provides information on members with axial compression in the plane of curvature. As discussed in Section 6.1, Design Guide 33 uses an equivalent straight column approach, where effective length factors are presented for arches. The design guide does not provide information for the in-plane buckling of rings; therefore, an effective length factor must be derived from the available equations.

Equations for the elastic critical load for the in-plane buckling of rings can be found in several publications on stability, including *Theory of Elastic Stability* (1961) and *Fundamentals of Structural Stability*. The in-plane buckling strength is dependent on the loading condition. The lowest buckling load is for the case where the load remains normal to the buckled shape during buckling, which occurs when a pressure load is applied around the perimeter.

The buckling force for this condition is  $P_{cr} = 3EI_x/R^2$ . The critical force for elastic buckling about the strong axis of a straight column is  $P_e = \pi^2 EI_x / (KL)^2$ . Setting  $P_{cr}$  equal to  $P_e$  and solving for the effective length results in  $L_c = KL = 1.81R$ .  $R$  is the ring radius and the remaining variables are as defined in the *Specification*.

Chapter 6 of Design Guide 33 also provides information on the interaction of the axial force with the other internal loads in the member, including second-order effects.

Bo Dowswell, PE, PhD

The opinions expressed in Steel Interchange do not necessarily represent an official position of the American Institute of Steel Construction and have not been reviewed. It is recognized that the design of structures is within the scope and expertise of a competent licensed structural engineer, architect or other licensed professional for the application of principles to a particular structure.



STEEL SOLUTIONS CENTER





WWW.INFRA-METALS.COM



WWW.DELTASTEEL.COM

# YOUR STEEL PARTNER FOR A SUSTAINABLE FUTURE

## CUSTOMER SATISFACTION BUILT WITH STEEL

Through our strategically located service centers, knowledgeable sales staff and online customer portal, we exceed customer expectations with high-quality products and processing services.



ADVANCED PROCESSING CAPABILITIES  
DRILLING, PLASMA CUTTING, ROBOTIC COPING & MORE

LARGEST CARBON  
STRUCTURAL STEEL INVENTORY

SERVING THE COUNTRY'S  
INFRASTRUCTURE & RENEWABLE ENERGY NEEDS



YOUR **ONE-STOP** SHOP FOR ALL YOUR PROJECT REQUIREMENTS

**NASCC:  
THE STEEL CONFERENCE  
EXHIBITOR  
2024**

**BOOTH #1015**



### INFRA-METALS

- |                                |                                 |
|--------------------------------|---------------------------------|
| Atlanta, GA<br>800-833-9175    | Newtown, PA<br>800-899-3432     |
| Hallandale, FL<br>800-432-1146 | Petersburg, VA<br>800-435-0850  |
| Marseilles, IL<br>800-987-5283 | Tampa, FL<br>800-693-1361       |
| New Boston, OH<br>877-741-8806 | Wallingford, CT<br>800-243-4410 |

### DELTA STEEL

- Cedar Hill, TX  
800-284-7321
- Fort Worth, TX  
800-772-2762
- Houston, TX  
800-324-0220
- San Antonio, TX  
800-292-5828

## JOIN US IN SHAPING A SUSTAINABLE TOMORROW ONE STEEL BEAM AT A TIME!

CONTACT US TODAY TO BEGIN A PARTNERSHIP THAT WILL TRANSFORM THE WAY YOU THINK ABOUT STEEL SUPPLY.



# steel quiz

This special Steel Quiz will test your knowledge of words related to the gold standard for steel design and construction: The 16th Edition AISC *Steel Construction Manual*, released in 2023. Can't figure out the answers? Purchase your own copy today at [aisc.org/publications](https://aisc.org/publications) or visit our booth at NASCC: The Steel Conference.

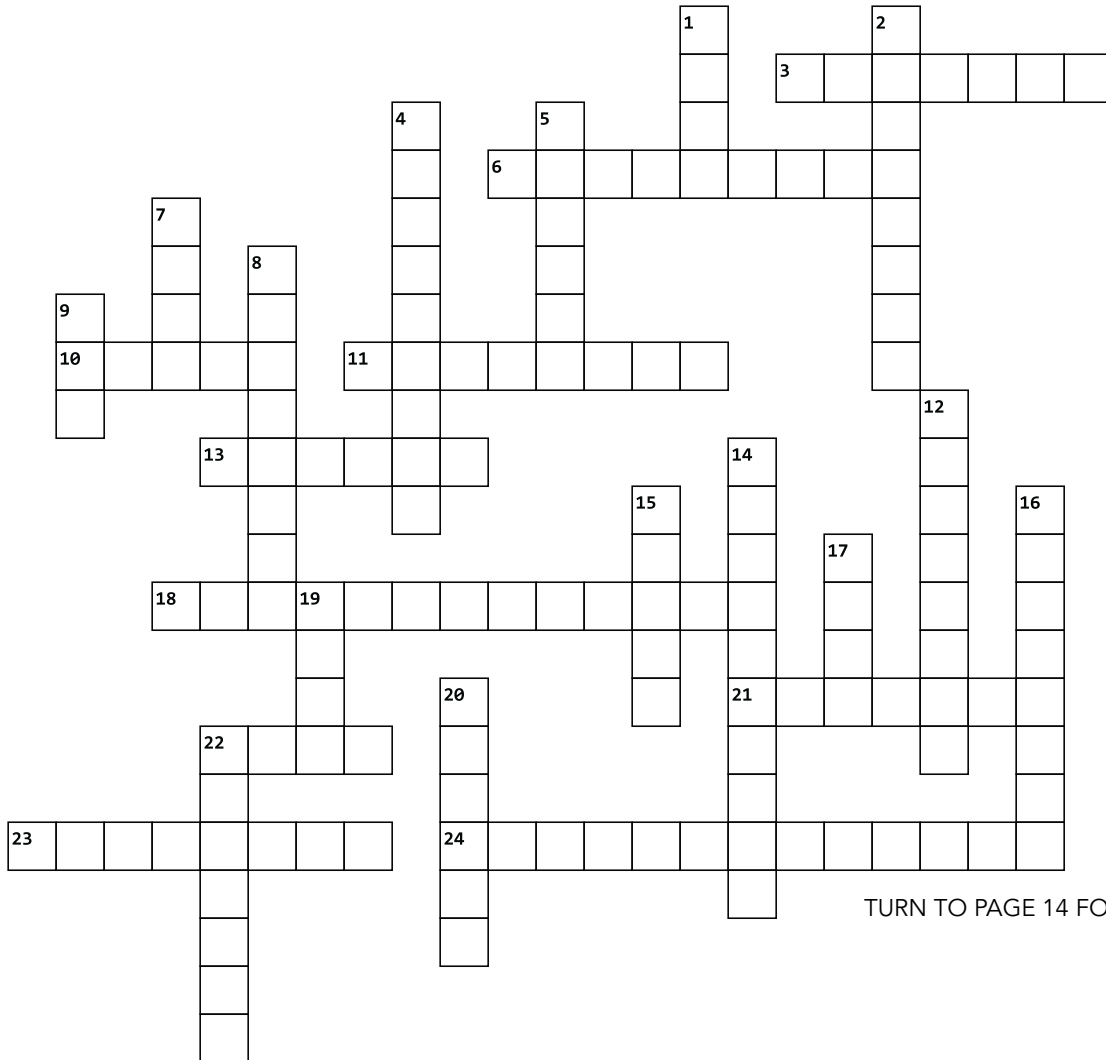

TURN TO PAGE 14 FOR ANSWERS

## Across

- 3 Method to design a weld loaded eccentrically normal to the plane of the faying surface that involves calculating an equivalent normal force
- 6 Allowable variation from specified values for material, fabrication, and erection
- 10 Colloquial name for a single-plate connection; a \_\_\_ tab
- 11 Sudden, brittle failure that occurs by cleavage at a stress level below the yield strength
- 13 Curvature fabricated into a beam or truss
- 18 Standard the *Manual* is based on
- 21 Term used to describe forces local to the gusset region of a V-, inverted V-, or X-type braced frame
- 22 Cutout made in a structural member to remove a flange
- 23 Accelerated corrosion due to significant potential difference between two different materials

- 24 Mathematical term for determining a value between two other known values, which should be used with caution in the *Manual* tables

## Down

- 1 OSHA-required minimum number of anchor rods for a column base plate
- 2 Type of tearing involving separation in highly restrained base metal caused by through-thickness strains induced by shrinkage of adjacent weld metal
- 4 AISC designation of a material specification that is commonly used in steel construction and reflects factors like ready availability, ease of ordering and delivery, and pricing (hint: indicated by black shading in Table 2-4,-5,-6)
- 5 Partially restrained and fully restrained \_\_\_ connections are combined in the Part 11 of the 16th edition
- 7 Transverse center-to-center spacing of fasteners

- 8 Gage for fasteners in the flange that provides for entering and tightening clearances, edge distance, and spacing requirements
- 9 210 new sizes of these shapes are in the 16th edition
- 12 Width of a \_\_\_ section determined by spreading the force from the start of a joint 30° to each side in the connecting element
- 14 Combination of structural elements and joints used to transmit forces between two or more members
- 15 A bolt that cannot see
- 16 Person the 16th edition is dedicated to; developed the uniform force method
- 17 Plate at column bottom
- 19 Small connection angle
- 20 Phenomenon that occurs in bolted joints with tensile bolt forces
- 22 Shape with a slope of approximately 2 on 12 on the inner flange surface





# SMITH-EMERY

Inspection • Testing • Metallurgy

## Assuring Structure & Life Safety Since 1904

Our knowledge and expertise assure your project's critical structural components are compliant with the prevailing requirements.

### Fabrication & Field Services

Full range of quality assurance and quality control services; inspections, testing, audits, Inspection Test Plan (ITP) development, QMP's and more to meet the needs of the owner or contractor.

### Advanced NDT & Laboratory Services

Phased Array Ultrasonics comprehensive field testing using the most advanced technology, including Phased Array Ultrasonic.

### Global & Domestic Reach

Resources, personnel and operations ready to deploy worldwide.

 **1.833.405.0536**  
 **steel@smithemery.com**  
 **www.smithemery.com**

 Los Angeles, CA  
San Francisco, CA  
Anaheim, CA  
Fresno, CA  
Oakdale, WA

 New York, NY  
Montreal, Quebec, Canada  
Shanghai, China  
Chumphon, Thailand



# steel quiz : ANSWERS



**STEEL SOLUTIONS CENTER**

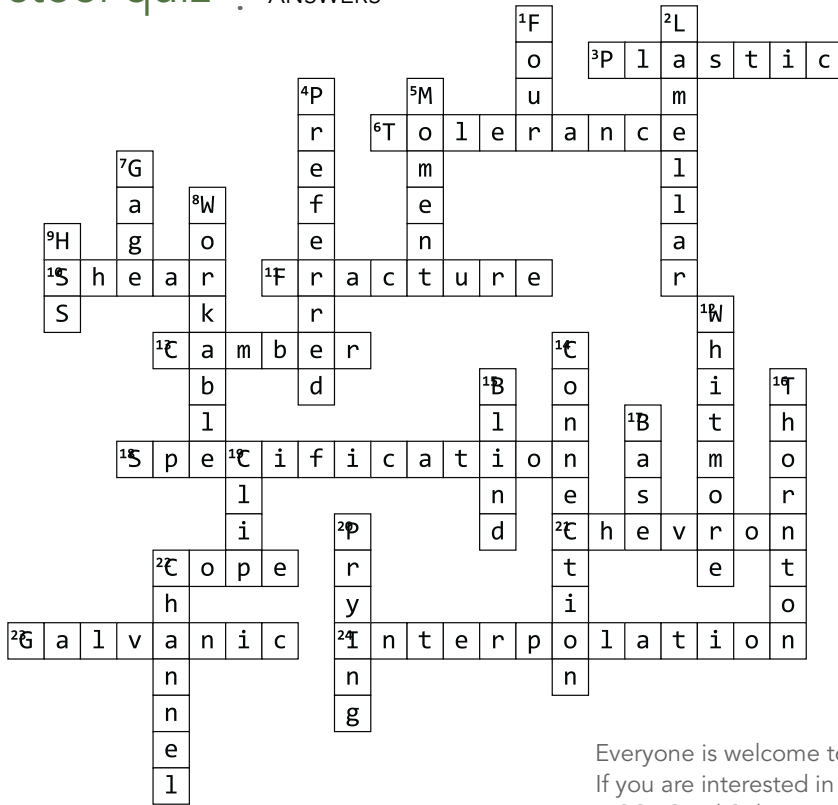

**Across**

- 3 Plastic
- 6 Tolerance
- 10 Shear
- 11 Fracture
- 13 Camber
- 18 Specification
- 21 Chevron
- 22 Cope
- 23 Galvanic
- 24 Interpolation

**Down**

- 1 Four
- 2 Lamellar
- 4 Preferred
- 5 Moment
- 7 Gage
- 8 Workable
- 9 HSS
- 12 Whitmore
- 14 Connection
- 15 Blind
- 16 Thornton
- 17 Base
- 19 Clip
- 20 Prying
- 22 Channel

Everyone is welcome to submit questions and answers for the Steel Quiz. If you are interested in submitting one question or an entire quiz, contact AISC's Steel Solutions Center at 866.ASK.AISC or [solutions@aisc.org](mailto:solutions@aisc.org).

## MOLDTEK

We are open to Joint Ventures, Mergers, Acquisitions and Strategic Partnerships with Structural Engineering firms.



*Choose Moldtek, where deep domain knowledge and technological prowess unite to tackle your challenges effectively.*

**CLIENT'S SPEAK :**  
'Moldtek is a true business partner as they truly align with our core values.'

65+ Clients

1500+ Projects

1M+ TONS

- 500+ Engineers, Checkers, Detailers & PM's generating 18,000+ tons/mo.
- Offering both Structural & Misc. Steel Detailing and Connection Design Services.
- Local Project & Client Coordinators and P.E.'s across different offices in the U.S.
- ISO Certified Processes, Established QA Systems & Procedures.
- Competitive Pricing, NISD Certified PM's, Effective Communication.

**NASCC 2024 Booth #1449**

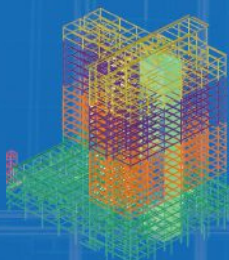
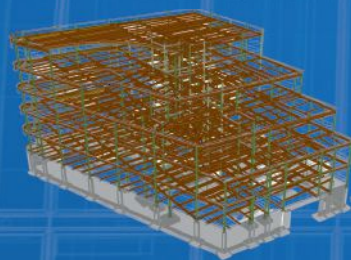

VISIT

EVALUATE

TRUST

Atlanta | Ohio



# Flush frame OPTIMIZED

**Vibration performance equal to wide-flange beams at up to a 35% weight savings**

New Millennium flush-frame connections feature a more efficient design that eliminates girder torsion concerns and added bracing. Our published set of standard flush-frame connections simplify design and specification. Construction is accelerated by eliminating blocking between joist seats. Add joist camber without additional time or cost. **Together, let's build it better.**

LEARN MORE



Flush-frame connection designed for efficiency



Standardized connections reduce design time



Joist reaction point occurs at beam centerline



SEE US AT NASCC **BOOTH 1117**



**NEW MILLENNIUM**

*A Steel Dynamics Company*

newmill.com

# Stay Stable

BY BO DOWSWELL, PE, PHD

Beam stability in industrial structures requires careful consideration of unique conditions during the design process.

**ALTHOUGH MANY** industrial structures are similar to buildings—and the AISC *Specification for Structural Buildings* (ANSI/AISC 360-22) applies to them—their unique characteristics can affect the member strength and stability.

*Specification* Section A1 defines other structures—and by extension, industrial structures—as “structures designed, fabricated, and erected similarly to buildings, with building-like vertical and lateral load-resisting elements.” Industrial structures have design constraints based on functionality, and the buckling strength of their flexural members is affected by the loading, bracing, and boundary conditions.

Loading, bracing, and boundary conditions can be unique in industrial structures. And because the *Specification* applies to buildings and building-like structures, engineers should weigh the effect of these special conditions in the design process for industrial structures. There are several important areas to consider.

## Boundary Conditions and Simple Shear Connections

Let’s start with boundary conditions at beam ends, which are determined before the analysis. For example, pinned supports are assumed at both ends when designing a simple beam, as shown in Figure 1. These supports, which define the boundary

conditions for flexure, prevent vertical translation and allow rotation. The boundary conditions for lateral-torsional buckling (LTB) should also be considered for unbraced beams.

The lateral-torsional buckling equations in *Specification* Chapter F were derived assuming a rigid torsional (twisting) restraint at each end of the unbraced length, as stated in *Specification* Section F1(b): “The provisions in this chapter are based on the assumption that points of support for beams and girders are restrained against rotation about their longitudinal axis.”

The proper LTB boundary conditions are often idealized as fork supports, preventing vertical translation, lateral (out-of-plane) translation, and twisting. Many simple shear connections have adequate torsional resistance to meet the requirement in *Specification* Section F1(b). The 16th Edition *Steel Construction Manual* (Part 10, page 10-8) recommends that the minimum length of simple shear-framed connections be one-half of the T-dimension of the supported beam.

Satisfying that recommendation results in a reasonable level of torsional resistance for most connections. However, special considerations are often required when beam connections provide ambiguous torsional resistance, such as with unframed ends and coped beams.

The most common simple shear connections for heavy industrial structures are double-angle connections, shown in Figure 2a. The torsional resistance of these connections is usually deemed adequate without further consideration. Similar torsional resistance is provided by shear end-plate connections (Figure 2b), which are sometimes preferred for galvanized beams because the amount of seal welding is reduced. Also, for shops that use robotic welding, end plates may be preferred over clip angles due to the increased welding clearances at the end plates.

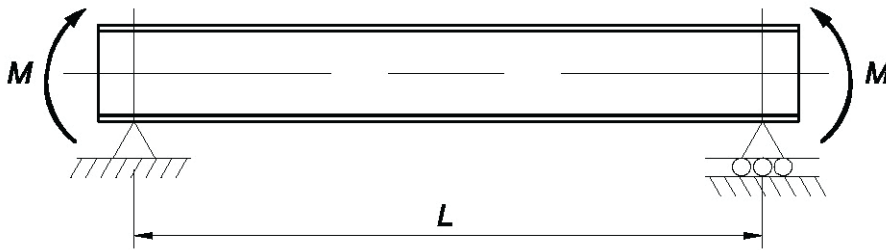
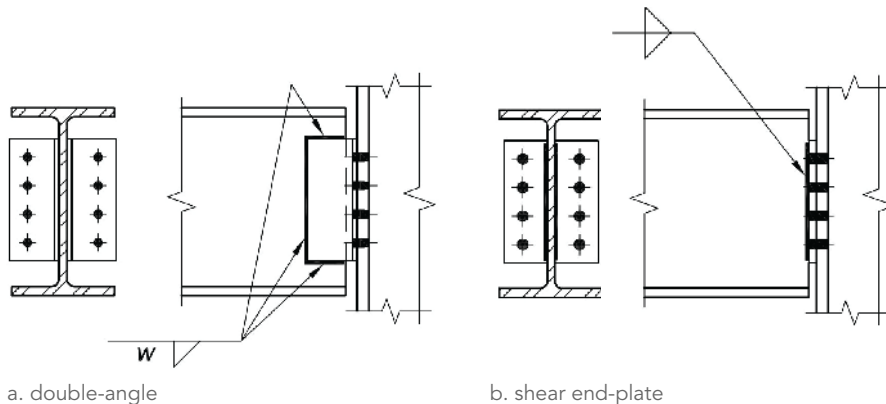

Fig. 1. Simple beam.



a. double-angle

b. shear end-plate

Fig. 2. Common simple shear connections.



## Floor and Roof Systems

Many buildings have floor and roof systems that can also provide top flange lateral panel bracing for beam stability. However, the primary purpose of many industrial structures is to support the loads associated with a process. These structures are often exposed to weather and do not have floors or roofs. Where floors and roofs are present, differences in floor/roof systems between buildings and industrial structures can affect the LTB strength of beams.

For some industrial structures, an entire framing level can support a floor system. When a floor is not required, access to machinery and equipment is typically provided by walkways and platforms located on only a portion of the framing level area. In many cases, entire framing levels are “bare,” indicating that only the structural steel framing is present without a floor, walkway, or platform.

Metal bar grating is usually used for floors, walkways, and platforms of exposed industrial structures. Because grating panels have limited in-plane shear resistance, grating is usually deemed ineffective for lateral panel bracing. Additional practical considerations typically lead to the limited bracing effect of grating:

- Grating panels are sometimes removed permanently during a retrofit or temporarily for access (for example, to install equipment)
- Grating-to-beam connections can be compromised by corrosion or fracture (caused by thermal stresses, vibration fatigue, and impact)
- The engineer may not have complete control over the installation process and may not be informed if the grating-to-beam connection is changed from directly welded to saddle clips

The lack of top flange lateral panel bracing at many beams in industrial structures has an obvious effect on the unbraced length,  $L_b$ . Another factor resulting from the lack of lateral bracing at the beam ends is the potential effect on the torsional restraints.

## Unframed Ends

To satisfy the boundary conditions assumed in *Specification* Chapter F, *Specification* Section J10.7 requires “At unframed

ends of beams and girders not otherwise restrained against rotation about their longitudinal axis, a pair of transverse stiffeners, extending the full depth of the web, shall be provided.”

The *Specification* glossary defines an unframed end as “the end of a member not restrained against rotation by stiffeners or connection elements,” where the implied rotational restraint is about the beam longitudinal axis. When proper torsional restraint is not provided at the unframed ends of unbraced beams, web distortion can reduce the beam buckling strength. This web bending distortion for a seated beam is shown in Figure 3.

For beams supported on bearing plates, restraining methods are discussed in *Manual* Part 2, pages 2-18 and 2-19. Restraint at stiffened and unstiffened seated connections is provided by supplementary angles connected to the beam top flange or the beam web, as shown in *Manual* Part 9. Various conditions in some industrial and nonbuilding structures require special consideration.

Seated crane girders have lateral crane loads that must be transferred from the top flange of the girder into a supporting member. Tiebacks are designed to transfer these lateral forces into the column. Figure 4—from AISC Design Guide 7: *Industrial Building Design* (Third Edition)—shows a typical tieback. Tiebacks also function as top flange stability bracing to satisfy the boundary conditions assumed in *Specification* Chapter F.

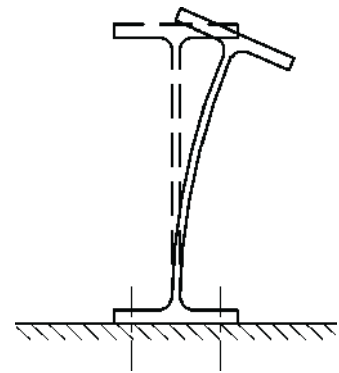

Fig. 3. Web distortion of a seated beam without proper torsional restraint at the ends.

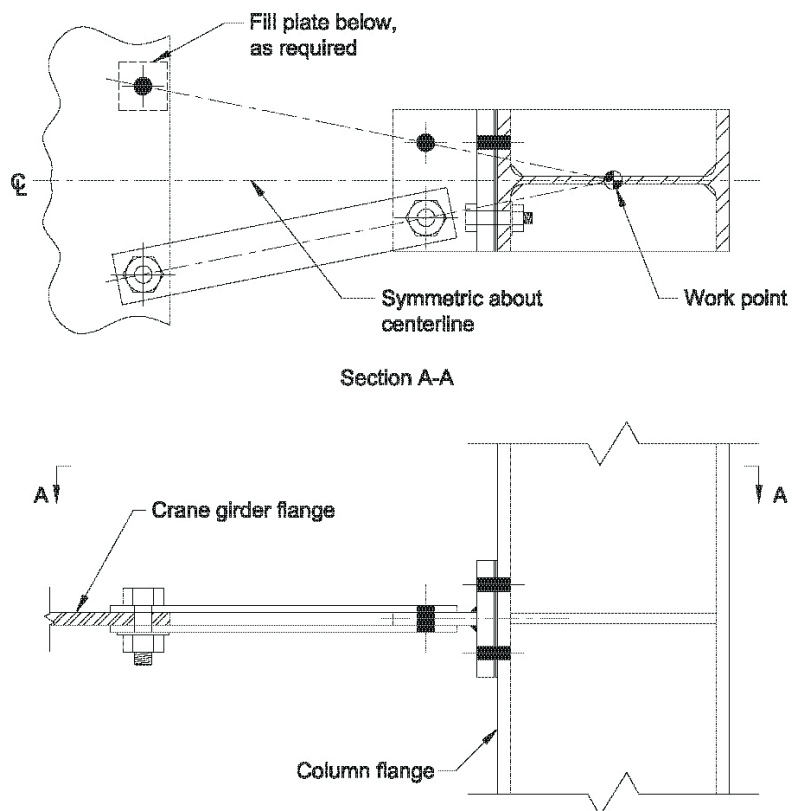
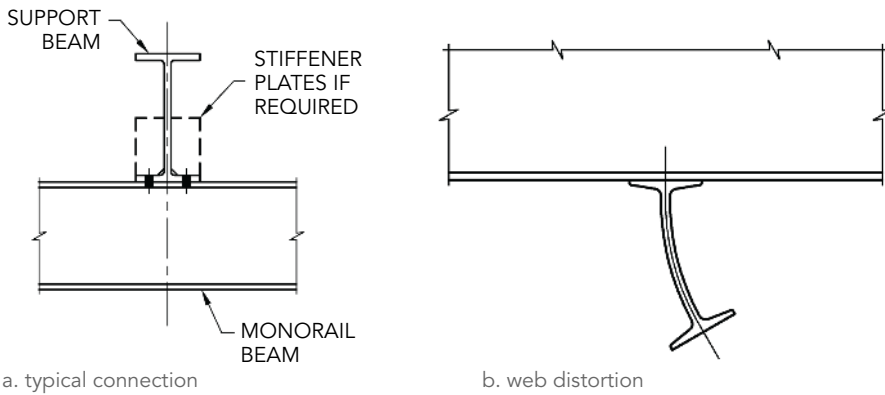

Fig. 4. Typical crane girder tieback.



a. typical connection  
 Fig. 5. Underhung monorail beam.

Providing torsional restraints at the ends of unbraced spans is impractical for some seated beams in industrial and nonbuilding structures. That issue can occur when the support location varies based on field conditions, such as framing around roof openings and temporary supports.

In these cases, where the beams are designed with unframed ends, the LTB strength can be reduced by increasing the effective length according to *Structural Use of Steelwork in Buildings* (British Standard 5950). The equations in *Specification* Chapter F can be used with an effective unbraced length equal to  $L_b + 2d$ , where  $d$  is the beam depth.

A similar condition exists at underhung monorail beams, where the beam top flange is connected to support beams, as shown in Figure 5a. The potential web bending distortion is shown in Figure 5b. Because the trolley runs along the bottom flange, both transverse web stiffeners and a bottom flange lateral brace will interfere with the trolley passage. Therefore, these beams are designed with unframed ends, and the effective unbraced length method discussed in the preceding paragraph is applicable.



a. Heavy industrial structure  
 Fig. 6. Single-coped beams.

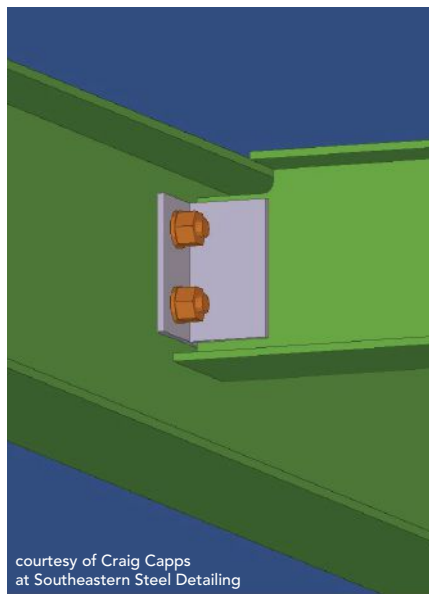

b. detailing model

### Coped Beams

Beams are often coped to allow framing at the same top of steel elevation as the supporting beam. Where practical, the depth of the supporting beam should be greater than that of the supported beam. That allows the use of single-coped beams, which are shown in Figures 6 and 7a. Double-coped beams (Figure 7b) are required when the supporting beam depth is approximately the same as the supported beam depth. Compared to double-coped beams with similar geometry, single-coped beams have greater local cope strength (see *Manual* Part 9) and greater LTB strength. They are also more economical to fabricate.

For beams without lateral bracing near the cope, the local cope strength (see *Manual* Part 9 pages 9-7 through 9-10) and the LTB strength of the beam are interdependent. Because the torsional restraint depends on the cope geometry,

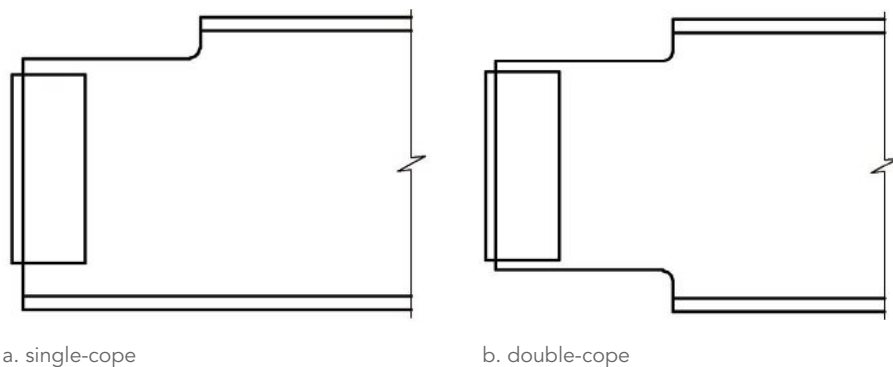

a. single-cope  
 Fig. 7. Coped beams.



the boundary conditions assumed in *Specification* Chapter F may not be satisfied for unbraced beams with large cope dimensions. This condition is briefly discussed on *Manual* page 9-10, which references two journal papers that contain the appropriate design equations.

For common cope geometries, the effect on the LTB strength is usually negligible. However, special conditions can require an increase in the cope dimensions, causing a significant reduction in the LTB strength. Round process equipment such as bins, silos, and large industrial ductwork is often supported on skewed beams located around the perimeter of the equipment. That increases the cope length, as shown in Figure 8.

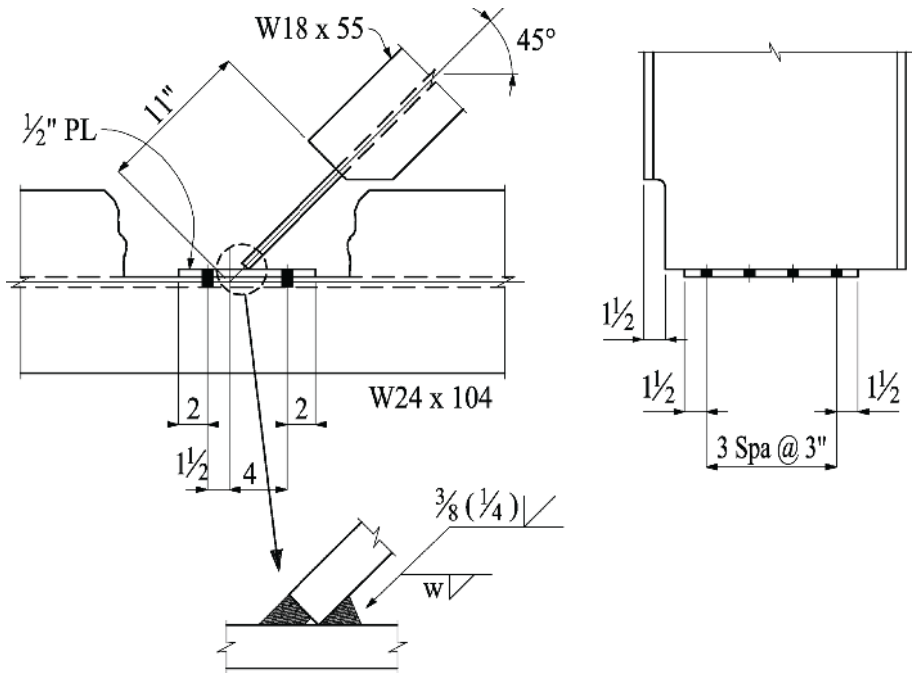

Fig. 8. Skewed beam connection.



## AUTOMATED FITTING AND FULL-WELDING FOR THE STEEL FABRICATING INDUSTRY

The Fabricator is the premier welding system for structural steel, whose flexibility lets you choose on-the-fly between Fit & Weld or only Fit. We offer the quickest turnarounds, maximum efficiency in space utilization and choice-based flexibility – that’s what makes our ROI the fastest on the market.

- Ensure on-schedule project with reliable and flexible welding capacity;
- Access a flexible workhorse free from staffing constraints;
- Achieve consistent, high-quality welds, beat material tolerances;
- Secure the quickest return on investment in the market.



Voortman USA LLC / 26200 S. Whiting Way / Monee, IL 60449 - USA / +1 708 885 4900 [WWW.VOORTMANCORP.COM](http://WWW.VOORTMANCORP.COM)





**New from InfoSight: The KettleTag® PLUS EZ™ makes start-to-finish traceability easier than ever by removing the need for time-consuming laminating.**



- Patent pending
- Designed for fabricators and galvanizers
- Text and barcodes remain readable through all nine steps of galvanization
- Print on demand at point of application
- Up to 3x faster

**CONNECT WITH US AT:**

**NASCC: THE STEEL CONFERENCE**

March 22–24 | San Antonio | Booth 1035

Visit **INFOSIGHT.COM**

**WE BARCODE DIFFICULT STUFF®**

20700 US Highway 23, Chillicothe, OH, 45601

steelwise

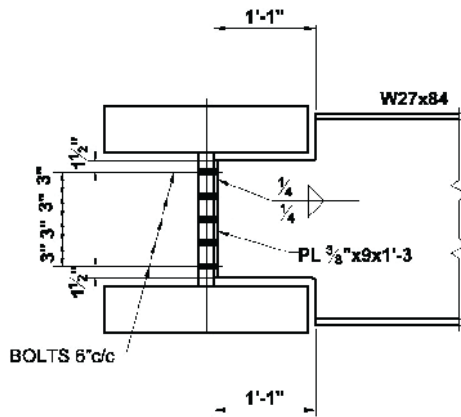

Fig. 9. Double-coped beam framing into a large member.

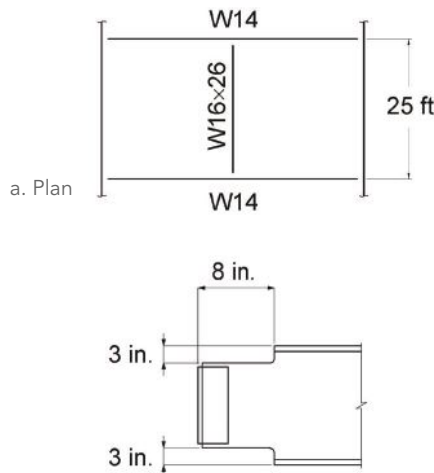

Fig. 10. Design example from AISC Night School 31.

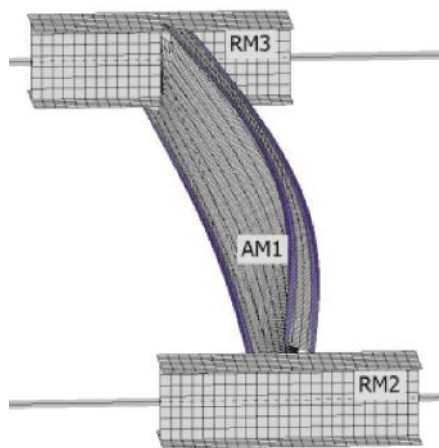

Fig. 11. Mode 1 buckled shape from the IDEA StatiCa finite element model.

Uncommon cope geometries are also required when beams frame into heavy members, as shown in Figure 9. This condition can occur when beams frame to heavy truss chords and where unconventional beams are used to satisfy geometric constraints such as clearances for headroom and machinery maintenance or removal. Although unusual, the member size on retrofit projects can be limited by the clearance in a congested area of a plant, causing small cross-sectional dimensions with thick elements.

Figure 10 shows a design example from Session 6 of AISC Night School 31: Beam Design and Stability, where the available strength of an unbraced W16x26 beam with large double copes at each end was calculated. The beam and cope geometry was modeled using plate/shell finite elements using IDEA StatiCa software. A critical load analysis resulted in a buckled shape for Mode 1, which is shown in Figure 11, where twisting in the coped region was observed. Compared to a similar non-coped beam, the critical load analysis resulted in a 25% reduction in the lateral-torsional buckling moment due to the copes.

The effect on the LTB strength is usually negligible for common cope geometries. With the large cope dimensions and thin beam web, this design example does not represent common practice for industrial structures. The geometry was selected to show a significant reduction in the LTB strength. ■

*The author will host a session titled “What Designers Need to Know About Beam Stability for Industrial Structures” March 21 at 2024 NASCC: The Steel Conference in San Antonio, Texas.*



**Bo Dowsell**  
([bo@arcstructural.com](mailto:bo@arcstructural.com)) is a principal with ARC International.



Please come visit us at  
**HALL 1, BOOTH 425**

# VALIANT + KATANA

Valiant automatic CNC drilling line combined with Katana band saw ranges from 18" x 18" up to 80" x 32" beam size in variable lengths.

- Independent processing of different operations at the same time on **4 sides** of the beam: drilling, milling, marking, scribing, tapping, and chamfering
- A wealth of shapes is possible for **milling** giving a wide field of application
- Advanced routing to prepare the material for the assembly and welding stage
- **Steel Projects** office software automating material optimization and line programming



## JUMBO BEAM

Valiant and Katana leading innovative design and features allow the processing of jumbo beams up to W36x925. The shown sample has been carried out in:

**5 min**  
16sec

Total drilling time

**10 min**  
59sec

Sawing time (1 cut)



**FORWARD**  
INNOVATIVE SOLUTIONS

**FICEP Corporation**

2301 Industry Court - Forest Hill Industrial Park - Forest Hill, MD 21050 - USA  
Tel +1 410 588 5800 • Fax +1 410 588 5900 • email: info@ficepcorp.com

[www.ficepcorp.com](http://www.ficepcorp.com)



# EMPOWER THE **FUTURE**



**SINGLE SPINDLE DRILL LINE**

 4007 W Alva Street Unit B Tampa, FL 33614

 +1 (813) 351 71 00

 [info@akyapakusa.com](mailto:info@akyapakusa.com) / [www.akyapak.com](http://www.akyapak.com)

 / [akyapakmakine](https://www.instagram.com/akyapakmakine)  
[in / akyapak-usa](https://www.linkedin.com/company/akyapak-usa)



# Bridge Authority

INTERVIEW BY GEOFF WEISENBERGER

Rob Connor has helped make Purdue University a leader in steel bridge research.

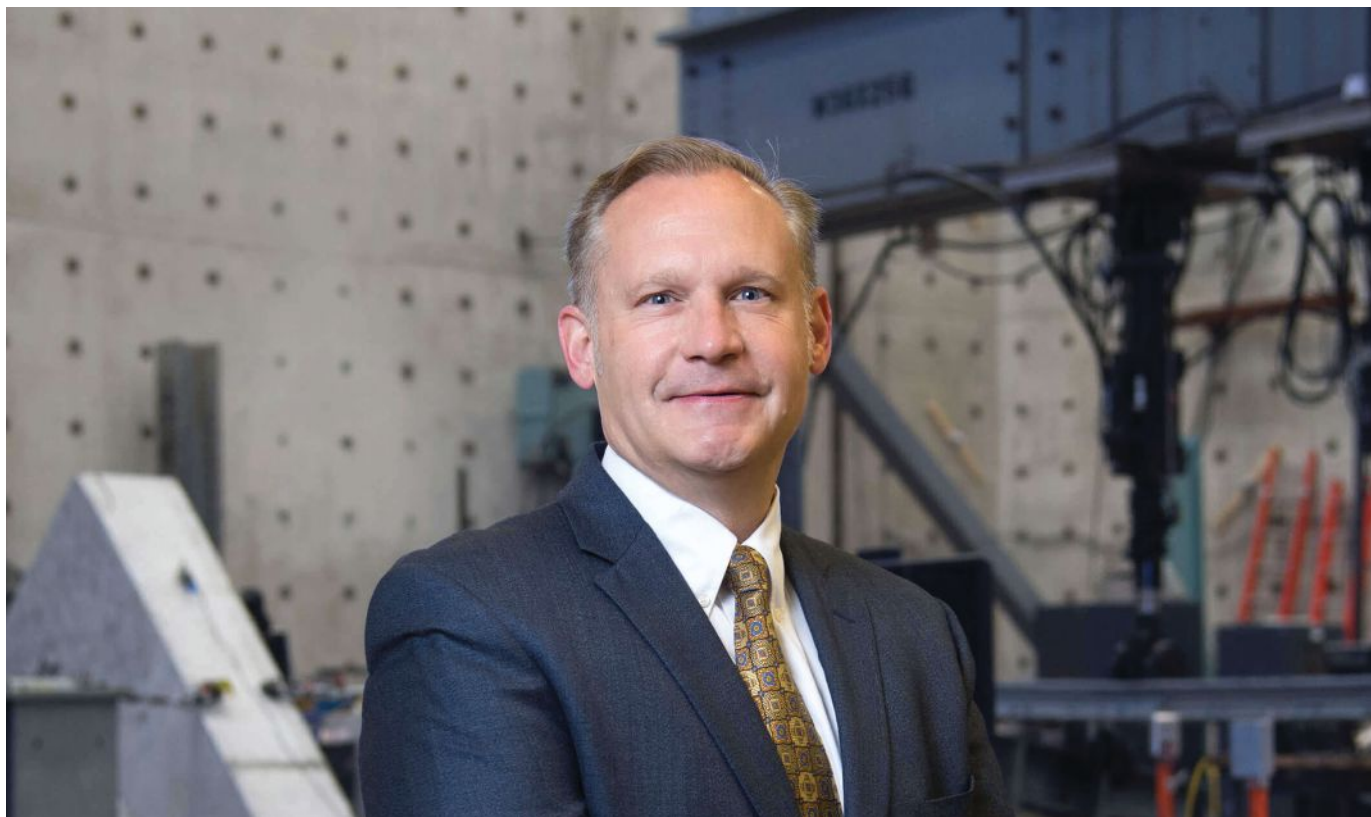

**STUDYING AND TESTING** bridge fatigue has made Rob Connor anything but tired.

Connor, the Jack and Kay Hockema professor in the Lyles School of Civil Engineering at Purdue University, won a 2023 AISC Lifetime Achievement Award and the 2018 T.R. Higgins Lectureship Award for his significant contributions to advancing design in steel bridge fatigue, fracture,

and other performance issues. He's also the director of two cutting-edge Purdue engineering facilities: The Center for Aging Infrastructure (CAI) and the Steel Bridge Research Inspection Training and Education Center (S-BRITE).

Connor's research interests have focused on fatigue and fracture, field testing and remote monitoring of structures, nondestructive testing, large-scale structural testing in real time, and redundancy, among other areas. He has helped grow S-BRITE into a nationally acclaimed training and test center that obtains decommissioned bridges from around the country.

Connor spoke with *Modern Steel Construction* about his career, research projects, S-BRITE, and more.

**What got you into the world of engineering?**

I did my undergraduate work at Drexel University in Philadelphia, and I'm from the coal mining region of Northeastern Pennsylvania. I started as an electrical engineer because I naively thought it involved lighting and wiring. I liked working with my hands. But it was mainly ones and zeros, which wasn't my thing.

Then I took a class called statics, where I first learned about forces. The professor said if you go outside the building after class, there's a railroad bridge—look at it, and you'll see the pins and rollers we discussed in class. I went out, saw a train going over it, and thought, "I can see that and relate to that." That week, I switched to civil engineering and focused on structural



Field Notes is *Modern Steel Construction's* **podcast series**, where we interview people from all corners of the structural steel

industry with interesting stories to tell.

Listen in at [modernsteel.com/podcasts](https://modernsteel.com/podcasts).

A bridge at Purdue's S-BRITE Center



engineering. That little thing changed my direction in engineering.

**Were you in the design world for a while first, or did you go straight into teaching?**

I graduated from Drexel in 1990 and started work with a company called Greiner Engineering, which has since been bought and absorbed into other companies. I took a job there because they had great experience in bigger bridges. I was also taking graduate classes part-time. I worked for about four years doing bridge inspection and design in the Philadelphia area.

**How did you get to Purdue?**

That's a long path. I went to Lehigh University for my grad work in 1994 because I wanted to know more about fatigue and fracture. I did my master's and PhD there, then stayed as a research engineer. I loved the work there. It was a great learning atmosphere, especially in fatigue and fracture. But I wanted to have a little more involvement with students.

An opportunity arose at Purdue University, which had just built a gigantic structural engineering lab. I joke that it still had "the new lab smell" when I arrived. That was back in 2005. I was fortunate enough to get hired, and I've been there since.

Amit Varma, a good friend from my PhD days at Lehigh, had also started at Purdue

about a year earlier. He's also a Higgins Award winner. Mark Bowman and Judy Liu, other researchers I knew, were also there. It had a good base of steel people.

**What was your first big research project?**

That was when I was still at Lehigh—my first National Cooperative Highway Research Program (NCHRP) project. It was on heat straightening of girders and the effect on their fatigue and fracture performance. That led to many other NCHRP projects that probably put all the gray hair on my head. But that was the first big one.

At Purdue, we've been very fortunate to land some great projects. I can't pick a single project, but I have a theme I've worked on for 10 to 15 years: trying to rationalize the topic of the fracture-critical member. That has been a career-long focus through multiple projects examining inspection, inspection reliability, and behavior system analysis for big fracture tests. I've enjoyed that theme, and it started at Purdue.

**What is the significance of the terminology change from fracture-critical members to non-redundant steel tension members?**

It's a game-changer for the steel bridge industry. Fracture-critical is a terrible term from a public relations perspective. The idea is that a bridge without enough

redundancy or perceived redundancy would probably collapse if one component fails. If you think about an airplane, the landing gear is fracture-critical. If it fractures due to a fatigue crack, that's a bad day. If a pilot said, "Welcome to the fracture-critical aircraft," you'd probably get off. But we called certain highway bridges that. It's not an attractive term.

Fracture-critical bridges are subjected to special requirements in fabrication and design. However, the big issue is the long-term in-service inspection. The required in-service arm's length fatigue inspection every two years is expensive and risky for the inspectors because they must get up close to the bridge. You're closing lanes, causing traffic backups, and risking traffic incidents.

My 2018 T.R. Higgins lecture tried to rationalize that rather than putting a finger to the wind regarding how to manage steel structures that are deemed to have nonredundant members. Instead, we could take an integrated approach to ensuring reliable long-term performance.

After more than a decade of research, the work resulted in codified approaches that were incorporated into two AASHTO Guide Specifications. These Specifications allow engineers to evaluate a member traditionally classified as a fracture critical member and determine the consequence of member or component failure. Depending on the outcome of the analysis, various in-service inspection strategies that are tailored to the member can then be employed.

AASHTO approved these documents in 2018. However, the federal laws governing bridge inspection needed to catch up to allow full implementation. When the new Code of Federal Regulations came out in June 2022, the industry could fully implement the AASHTO Guide Specifications, and that's a game-changer for the steel bridge industry. We can now treat these members more rationally. We can use efficient designs, such as twin tub girders or trusses, and explicitly consider redundancy. We don't have to worry about the consequence of a member failing because we do the analyses to verify various failed member scenarios. The analysis also identifies the truly critical members, should they fail, thereby giving owners an engineering-based reason to focus inspection efforts on the components with the most risk.



HNTB gave a presentation that revealed they're using the work and incorporating the concepts into their designs. Several state departments of transportation are using it, from what I understand, and the consulting community is also implementing the specifications. It's neat to see a rational approach to addressing an assumed failure mode come to fruition.

**What are some recent and current projects in Purdue's structural engineering lab?**

The lab is bustling. It's a great facility. The strong floor for testing is about 11,000 sq ft. For scale, we have a 35-ft span railroad bridge with ties and rails in the lab. We're doing some testing on it. I'm doing small pull plate tests with a student. We also have some big bridge girders with pack out corrosion we are testing. We're continuing down the path of redundancy or built-up members.

One challenge owners face with older bridges is related to pack-out corrosion, where plates get bent apart. Corrosion gets in between old, riveted members; they bend and look bad. But more research into its actual effect on capacity and fatigue is necessary.

So we acquired some members with real damage from old bridges. We also simulated pack-out damage of our own. We tested these in the lab—long-term fatigue tests, strength tests, cold temperature tests, and followed up with finite element analysis. Then, we did the same thing on the compression portion of the member to see if it would buckle more quickly or lose capacity.

The objective is to determine when this problem needs to be addressed and how we can get guidance into the AASHTO *Standard Specification for Highway Bridges*. That has been an ongoing one and has been a lot of fun. There is a lot of other large-scale work going on by my colleagues that is great for the students to observe.

**Can you describe Purdue's S-BRITE center and what goes on there?**

S-BRITE is about a 20-acre outdoor facility, and we've developed about 10 acres that Purdue provided for the facility. (Editor's note: Read more about S-BRITE in the October 2019 issue of *Modern Steel Construction* titled "Wanted: Old Steel Bridges").

I teach several courses in fatigue, and it's always a challenge to explain to students and professional engineers or inspectors where exactly to look for cracks, what a crack really looks like in service, and other considerations. We also realized many inspectors have negligible or zero firsthand experience spotting cracks, at least when they are new inspectors. Furthermore, new bridges rarely have any issues with fatigue cracking.

To improve the training, I thought it would be neat to keep a few components with damage, whether that's due to corrosion, fatigue, or impact damage. I pitched it to the Indiana Department of Transportation, and they supported it. The Federal Highway Administration also thought it was a unique idea. As we discussed the concept with others, we found many other state departments of transportation were excited to use out-of-service bridges to improve training.

The main portion of S-BRITE is a training facility where we have four complete bridges and many other components from bridges. As you can imagine, we want damaged members, because we're trying to train bridge inspectors and designers to detect damage, identify problem details, and observe retrofits firsthand. It also helps with undergraduate and graduate steel classes where the professor is trying to explain steel details, such as very large-bolted joints. We have the largest collection of components from the Interstate 35W bridge in Minneapolis that collapsed in 2007.

It's an incredibly unique facility and allows some great collaborative research opportunities. For example, if someone is interested in using drones for inspection, we have bridges with damage, but we don't have to worry about worker fall protection, traffic control, or risk to the public because it's in a controlled environment.

Another big part is our outreach of professional training, where we help DOTs with problems and provide training to their staff.

**What's your acquisition process for bridges and members that go to S-BRITE?**

The center is well known now, especially in our partner states. DOTs will

reach out and mention they have a bridge going out of service in a year or two, ideally.

Recently, the Texas Department of Transportation said they have some components from a bridge. They sent the plans and inspection reports and asked if those would aid training and research at the center. We then review the information and let them know what component we would ideally like to save. That's generally how the acquisition process happens right now. Any state DOT that knows of us can do that. It doesn't have to be a partner state.

We tell them we can always say no, but once the components go in the melting pot, they're gone. If the members are unique or have characteristics of something that would be good to share with people, give us an opportunity. Generally, we pay for shipping and put it on our truck.

Some larger bridges arrive disassembled. We have a 90-ft span through truss, both truss lines, and all the floor beams. That came in four major pieces, and our staff put them back together.

The I-35W pieces draw people's attention. The other attention-grabbers are plate girders from the old Interstate 90 Dresbach Bridge in Minnesota with webs about 23 to 24 ft deep. Those girders are huge, and you can see them from a mile away. Those pieces are relatively short because they're so tall, but their scale has made an impression on many visitors. They all want to stand on the flange and have their picture taken. ■

*This article was excerpted from my interview with Rob. To hear more from him, find the March 2024 Field Notes podcast at [modernsteel.com/podcasts](https://modernsteel.com/podcasts).*



**Geoff Weisenberger** ([weisenberger@aisc.org](mailto:weisenberger@aisc.org)) is the editor and publisher of *Modern Steel Construction*.

# The Significance of Soft Skills

BY ERIN CONAWAY, PE

Four engineers concur that non-technical acumen was crucial in their rise to leadership positions.

**ENGINEERS HAVE** a wide selection of technical learning opportunities that are, of course, fundamental to the profession. Their benefit is only worth so much, though, if unaccompanied by soft skills that relate to working and interacting with other people. Soft skills are an oft-overlooked piece, but they're just as important for a successful career in engineering.

At 2023 NASCC: The Steel Conference, a panel of engineering experts provided their perspectives on what newer engineers should know to progress successfully in their careers, with a focus on leadership and business-related skills. They also discussed what leaders should emphasize within their own companies to create future leaders.

Similar sessions will take place at the 2024 Steel Conference in San Antonio, Texas, March 20–22, namely “Business Issues Roundtable” and “Dynamic Leadership and Professional Development: A Guide to Success in the Architecture, Engineering and Construction Industry.” For a complete session list, visit [aisc.org/nascc](https://aisc.org/nascc).

Four prominent leaders in the structural engineering field and 2023 panel participants shared their thoughts on various industry topics, from career-path challenges to developing leadership skills.

## Why did you choose structural engineering and what has been your career trajectory?

**Erleen Hatfield, PE—Hatfield Group:** I wanted to be an architect, but I found my way to structural engineering because I loved learning how things work and how buildings stay standing. I went to school in Nebraska and ventured to New York to work on bigger buildings.

**Stephen Lucy, PE—JQ, now IMEG:** I knew at an early age I wanted to be a civil engineer because my father and uncle were. Initially, I focused on structural and fluid dynamics because I wanted to design

offshore oil platforms. Those were the largest structures being built when I was in college. The oil industry declined, and I shifted to structural consulting.

The tangible evidence of our work still excites me. My career path changed and accelerated when I was asked to go to England as engineering director for a joint venture my employer created with a London-based firm. When I returned, the size and complexity of my projects and my level of responsibility changed dramatically. That gave me the confidence to open an office for another firm (JQ), where I became CEO.

**Brian Morgen, SE, PE, PhD—Thornton Tomasetti:** Engineering careers ran in my family. My father and several uncles and aunts are in electrical, mechanical, and civil engineering. I worked in construction in high school and college and knew I wanted to design or construct structures in the community around me. The construction management program at Washington State University was in the architecture school, so I had to decide whether to attend the engineering or architecture school.

Math was a more natural fit for me, and I chose the civil engineering program. That led to a master's and PhD in structural engineering and my career in consulting. I spent 16 years at a world-renowned engineering firm with many influential coaches and mentors before shifting to Thornton Tomasetti in 2020 to run its Seattle office.

**Jeannette Torrents, SE, PE—JVA:** I chose structural engineering because I liked the idea of building my community and seeing tangible results of my problem-solving. I started as a design engineer at a small-to-medium consulting firm, and 20-plus years later, I am now the director of structural engineering at the same firm.

## What career path options do new engineers have today in structural engineering?

**Hatfield:** There are many options. The field is less of a ladder now and more of a lattice where someone can move up in a more flexible path, take time off, come back, and still be valued.

**Lucy:** The spectrum of options is wide. A structural engineering background is translatable to a variety of career options, including consulting, material suppliers, software development, technical sales, and construction.

**Morgen:** There is a huge need in traditional design and consulting fields. And, with technology advancing, demand is growing for computer and data scientists within structural engineering (or structural engineering folks with overlapping backgrounds in computer science).

**Torrents:** There are several. To name a few: Design, consulting, product development, and software development.

## What was your greatest career path challenge?

**Hatfield:** Starting my own firm was daunting. But during my career, trying to earn the respect of others has been a constant challenge.

**Lucy:** Understanding the value of the entire team, technical and non-technical, because so much of our education was based on individual performance. My team-building skills came from extracurricular programs like Boy Scouts, not through the classroom.

**Morgen:** Developing an effective and motivating leadership style that is based on being intentional, being transparent, understanding others' world views, and being self-aware that everything I do as a person in a position of leadership is observed and emulated.

**Torrents:** I had to overcome affinity bias and learn to articulate my goals and achievements to others.





**How do you find meaning in your career?**

**Hatfield:** Seeing a structure I designed get built is immensely gratifying. I also try to help others in their career and encourage young people to enter engineering.

**Lucy:** I work to make our industry the best career option and a preferred choice, as well as celebrating the wins of those around me.

**Morgen:** Seeing others around me grow in their professional development so they can learn to be challenged and genuinely love to come to work and be part of a collaborative process.

**Torrents:** I find meaning in contributing to our profession, in facilitating the success of others, and in delivering quality projects.

**What skills do you consider to be the most important for a new structural engineer to acquire?**

**Lucy:** Teamwork and communications. Understanding that you don't know everything and asking for assistance and guidance is good. This should not be frowned upon by leadership, as none of us know everything.

**Morgen:** Critical thinking. Ask a lot of questions, but don't just ask questions without thinking about the problem. Outline the problem, develop strategies to solve the problem, and then ask for advice on which direction is the best approach.

**Torrents:** Learning how to define the problem so you can solve the right problem. Soliciting input from all the stakeholders so that you have the perspective of the owner, user, and contractor when selecting a solution.

**What soft skills, or non-technical skills, have contributed to your career?**

**Hatfield:** Truly listening—to my managers, to clients, to peers—has been a huge help to my career.

**Lucy:** Listening to learn the goals of others, including both internal and external clients. Communication, both written and verbal. Business skills and recognition that we are a business first that just happens to offer engineering services.

**Morgen:** Being in the moment, active listening and thoughtful communication.

**Torrents:** Communication and learning to tailor my message and delivery to my audience. I had to learn to listen beyond the words I heard. Also, adaptability and flexibility—clearly defining my priorities so that I know when to compromise.

## How did you acquire those soft skills?

**Hatfield:** I read books and articles about emotional intelligence and found mentors.

**Lucy:** I had multiple mentors within my firm and in other areas of our industry. I learned through repetition and accepting and learning from my mistakes. Valuing external consultants as buyers of expertise is why many of our firms exist.

**Morgen:** I looked at every assignment as a way to grow and learn. That happens by watching and listening to those in leadership positions. See what works and what you think doesn't work. Then, aim to develop your own style of leadership and implement it. When mistakes happen, own them. When rewards happen, give credit to those who supported you.

**Torrents:** I did a lot of self-study and took advantage of opportunities. I pushed myself outside of my comfort zone.

## What type of soft skills training should a new engineer pursue?

**Hatfield:** Negotiation skills. Everything is a negotiation.

**Lucy:** Communication. Business skills can come later, so focusing on an MBA straight after an engineering degree may not be the most productive route.

**Morgen:** Effective communication and organization.

**Torrents:** Interpersonal communication and conflict resolution.

## How do soft skills help new and experienced engineers in their careers?

**Hatfield:** They're crucial in being able to negotiate.

**Lucy:** If you work for a consulting firm, you can only consult if you can communicate. So, if you cannot convey your knowledge, it doesn't matter how brilliant, sophisticated, or complex your answer is.

**Morgen:** In our fast-paced working environment, we are asked to do more with little. So, being organized creates efficiencies and room for professional development opportunities. Effective, clear, and concise communication is key.

**Torrents:** If you can articulate your ideas and work with others to solve problems, you will be an asset to your project team, client, and firm.

## In your opinion, what makes a new engineer successful?

**Hatfield:** Asking lots of questions and understanding the point of every task assigned.

**Lucy:** Being inquisitive and striving for continuous improvement, and understanding that you only win if the team wins.

**Morgen:** Being open, inquisitive, asking questions, and a willingness to make and learn from mistakes.

**Torrents:** A combination of curiosity, learning, and a growth mindset.

## How has your definition of success changed throughout your career?

**Hatfield:** Success to me is having happy clients, happy co-workers and a successful project.

**Lucy:** This is a team sport, so play accordingly. That does not mean you cannot be individualist, but you cannot lead if you don't consider the team.

**Morgen:** My success only comes from the success of others around me who support my efforts. When I started my career, I was focused on how I could earn more opportunities. Now, I'm focused on what I can do to find ways for others to have opportunities for professional growth.

**Torrents:** My definition of success used to be very self-focused. Over time, it shifted to focusing on the success of others. I'm successful if I'm helping others achieve their goals and realize their potential.

## What advice would you give yourself if you could travel back in time?

**Hatfield:** Speak up.

**Lucy:** Understand everyone's path will be different, and that's OK. Set your goals and work toward them, but understand that goals and how you measure success will probably change.

**Morgen:** Outside of investment strategies in technology, I would have advised myself to talk less and listen more.

**Torrents:** Focus on your strengths, not your weaknesses. You don't have to excel in everything to be successful. You can be yourself and find your own path.

## What opportunities should an engineer seek out to progress in their career?

**Hatfield:** Identify the most successful person in your company and find a way to work with them.

**Lucy:** Mentorship—including being a mentor to others. Participation in professional organizations, including taking leadership positions. Pursue what interests you instead of what you think should interest you. Your career will span decades and should be fun and rewarding, not just work.

**Morgen:** Find an inside or outside organization that aligns with your passions and devote time and effort to it.

**Torrents:** For business and leadership skills, participate in young professionals groups, peer groups, and employee resource groups. For technical skills, become the in-house expert for a particular material, load, or software. ■

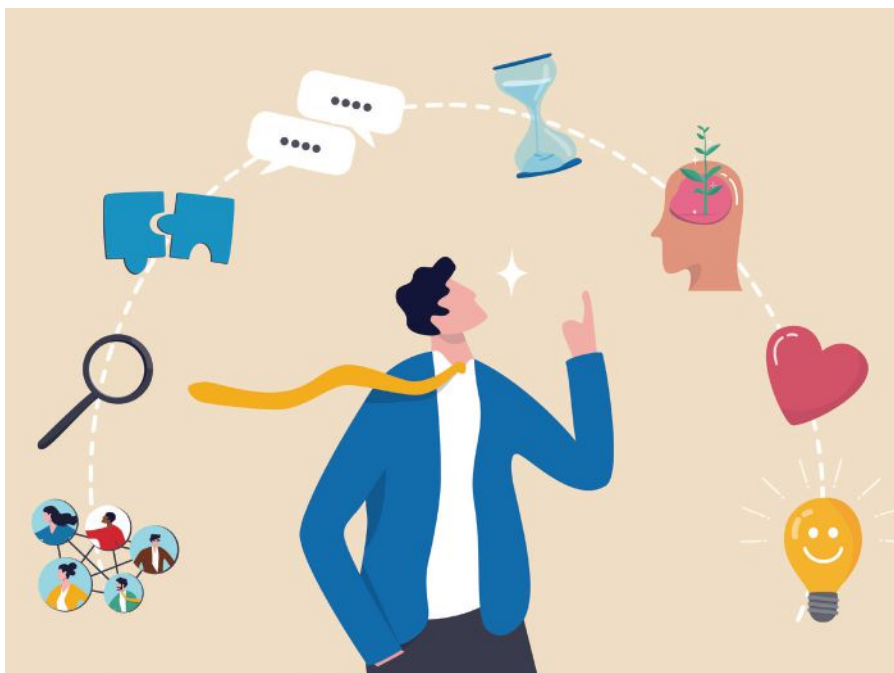



business issues



**Erin Conaway** ([conaway@aisc.org](mailto:conaway@aisc.org))

is the senior director of market development at AISC.

**Erleen Hatfield** is the managing partner of Hatfield Group. **Stephen Lucy** is an executive principal at IMEG. **Brian Morgen** is an associate principal and the Seattle office director at Thornton Tomasetti.

**Jeannette Torrents** is the director of structural engineering at JVA.



## 6-Axis Robotic Structural Steel Profile Cutting

With our Beamcut System 3D Robotic Profile Cutting Machine, you can cut virtually any shape on mild steel, stainless steel, and aluminum. Exceptional repeatability and accuracy using our technology and software. Equipped with Hypertherm high-definition plasma and Fanuc Robotics. Eliminate costly layouts and time-consuming grinding. Simplify your fabrication process. Minimize errors. Increase production speeds. Find out more:

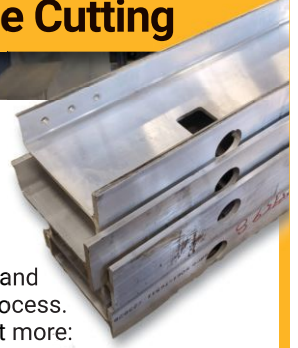

**BEAMCUT SYSTEMS**™  
Part of the Machitech Automation Group

Call Toll-Free: 1 (888) 988-7270  
Web: [beamcut.com](http://beamcut.com) • [machitech.com](http://machitech.com)

NASC: SAN ANTONIO  
THE STEEL CONFERENCE  
MARCH 20-22, 2024

Visit Us:  
Booth #232

## TAKE CONTROL OF CONFIGURATIONS & COORDINATION reduce the rework

Adjustable  
Telescoping  
Relocatable  
Pre-engineered  
Pre-assembled

Submit Your Plans for a  
Quote Today  
[quickframes.com](http://quickframes.com)

**QUICKFRAMES**™



# Fork in the Road

BY KEVIN DAMRON, PE, ADAM DeMARGEL,  
JOHN MICHAEL JOHNSON, AND  
BRAD ROBSON, PE







Environmental constraints prompted mid-project design changes to a new steel bridge in Kentucky.

Stupp Bridge

**THE APPALACHIAN DEVELOPMENT HIGHWAY SYSTEM** (ADHS) links an entire region to major thoroughfares and guides drivers through tricky terrain.

It has 33 highway corridors that connect 13 Appalachian states with Interstate highways. Corridor Q, one of its many corridors, spans from U.S. 23 in Kentucky to Interstate 81 in Virginia. Commonly known as U.S. 460, the corridor traverses mountainous terrain in Kentucky, West Virginia, and Virginia and slices through hillsides—sometimes high above valley floors.

Corridor Q's final Kentucky link is a twin bridge crossing the Russell Fork River, CSX railroad tracks, and Kentucky Route 80. Spanning that valley meant incorporating a bridge into U.S. 460's curving path more than 220 ft above it. Steel erection is complete, and the Kentucky Transportation Cabinet (KYTC) anticipates all Corridor Q sections will open by 2025. (Progress can be monitored with the Russell Fork Bridge camera found at [us460online.com](http://us460online.com)).

KYTC's District 12 guided the corridor design, from initial planning studies through design and construction.

Three unique issues at the Russell Fork Bridge affected its location and layout: an active railway loading site, an abandoned mine, and a habitat for a threatened species. KYTC's decades of experience building bridges in mountainous areas and the early involvement of other design partners helped arrive at a practical design that worked around constraints.

In the early planning stages, the preferred alignment went directly over a facility that stockpiled coal and loaded it onto trains in the valley next to the Russell Fork River. KYTC and Palmer evaluated options to span over the facility with aerial easements and strategically located bridge piers that created long spans. Eventually, though, cost comparisons favored purchasing the load-out facility versus building over it. The acquisition had an unanticipated short-term benefit: owning the rail spur's bridge allowed for its fast conversion to a vehicular bridge over the Russell Fork to provide construction access.

.....

The new Russell Fork River bridge crosses water, train tracks, and another road.





A zoomed-out view of the bridge's curved alignment.



A fabricated girder for the Russell Fork River bridge.

Stupp Bridge

Meanwhile, an abandoned coal mine sat more than 200 ft below the proposed roadway. Coal had been removed via the room and pillar mining method many years before, but concern about potential mine subsidence and how it could affect the twin bridges led the project team to hire a specialist to evaluate the subsidence risk and potential mitigation. In the end, the team decided to change the roadway's alignment to avoid the area of potential subsidence.

A third unique environmental challenge arrived in 2016 when the United States Fish and Wildlife Service listed the Big Sandy Crayfish as a threatened species, and the Russell Fork was a potential habitat field. Sure enough, Big Sandy Crayfish were discovered in the river directly in the proposed bridge crossing site. Extensive consultations with wildlife and environmental organizations determined that bridge piers could be located





Stupp Bridge

on the deeper side of the river but not on the shallow side where the crayfish made their habitat. The construction timeline adhered to seasonal restrictions on river work that protect the crayfish during spawning. KYTC also committed to placing a habitat structure in the river once all work is complete.

Solutions to those three challenges directly contributed to the bridge's slight S-curve and span lengths. Once a final alignment was fixed, structural engineer Palmer Engineering advanced the design to optimize initial cost, ease of construction, and long-term maintenance. The spans needed to cross the CSX railroad tracks, the river and Kentucky Route 80 on the complex alignment. The bridge needed to be built despite limited workspace below the proposed site, on the hillsides, and across the river and railroad.

Concrete spliced I-girders and steel plate girders were evaluated. The lighter steel



Design team members in front of a partially fabricated girder.





A close-up of the bridge's cross frames.

girders were chosen to facilitate erection over the railroad and the river, where crane placement locations were limited. The span over the river is the longest, at 285 ft. Other spans were proportioned for efficiency (ranging from 200 ft to 265 ft), and a constant web depth of 100 in. was maintained throughout. The web depth staying under 120 in. allowed for favorable steel prices, because the major U.S. plate mills competitively roll this size plate.

Each twin bridge consists of two six-span structural units with expansion joints at the abutments and between the two units. There are four lines of plate girders in each bridge. Combined, they feature over 6,200 tons of structural steel and 188 total girder segments that, if laid out end to end, would reach over 22,700 linear ft or 4.3 miles.

KYTC knew the twin bridges (2,810 ft and 2,875 ft long, respectively) represented a sizeable investment and invited contractors to submit Alternative Technical Concepts (ATCs). ATCs were submitted, and KYTC reviewed them confidentially. Contractors could include the approved ATCs as part of their bid on the project. Palmer Engineering wanted its design to be as competitive as possible with any ATC and contacted fabricator Stupp Bridge to ensure the layout and details were efficient and economical. Stupp Bridge did an in-depth review of the preliminary design and offered several suggestions, even though it had yet to secure the fabrication bid.

Two of Stupp's suggestions significantly altered the final design. First, hybrid girders were chosen for the bridge:

AASHTO M270 Grade HPS70W weathering steel is in the high-stress regions and AASHTO M270 Grade 50W weathering steel is everywhere else. The 70 KSI steel is slightly more expensive than the 50 KSI material, so it was used only in the most logical places, which were in the top and bottom flanges over the piers and in some of the bottom flanges in the middle of the spans. That resulted in lighter field sections overall, making the bridge erection more manageable for the contractor.

Second, and more importantly, Stupp Bridge suggested that the curves were mild and said it could slash fabrication costs if the girders did not curve with the roadway alignment. After evaluation, Palmer agreed that the difference in straight segments that kink at the field splice locations could accommodate the curves without greatly complicating the design. The plate girder segments ranged in length between 100 and 140 ft and weighed 25 to 45 tons each. Using low-maintenance weathering steel also saved the cost of shop- and field-painting.

The steel design was further optimized by using rolled angle cross frames shop-welded to gusset plates, which were then bolted to connecting stiffeners in the field. There were few unique cross frame piece marks for a bridge of this size, which allowed Stupp to minimize the set-up and fabrication time of these highly repeatable intermediate cross frames. Lateral bracing was used between a single bay of girders in each bridge and only over the piers and at the abutments.



# Curving the Circuit



## IDEAS<sup>2</sup> Award Winner: Circuit of the Americas (COTA)

An iconic 251-foot tall observation tower, offering a 360° panoramic view of the circuit, accommodating up to 10,000 spectators. CMRP meticulously curved 35 tons of steel, comprised of 73 pieces of curved 8" sch 40 pipe. These components begin with a precise 96" centerline radius, gradually expanding to a sweeping 360" radius before culminating in an expansive 1,349" radius at the base of the tower.

Visit Us at Booth 1122

NASCC:  
THE STEEL CONFERENCE  
**EXHIBITOR**  
2024

NASCC:  
THE STEEL CONFERENCE  
**SPONSOR**  
2024



**CHICAGO METAL**  
**ROLLED PRODUCTS COMPANY**

Call us at 866-940-5739

CHICAGO • KANSAS CITY

[cmrp.com](http://cmrp.com)



**1 Angle Leg Out** We bend ALL sizes up to:  
 10" x 10" x 1" Angle

**2 Angle Leg In**  
 10" x 10" x 1" Angle

**3 Flat Bar The Hard Way**  
 24" x 12" Flat

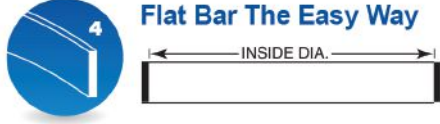
**4 Flat Bar The Easy Way**  
 36" x 12" Flat

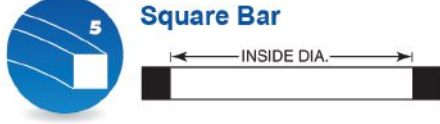
**5 Square Bar**  
 18" Square

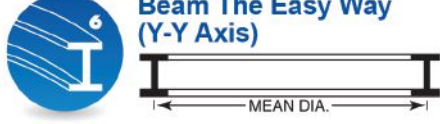
**6 Beam The Easy Way (Y-Y Axis)**  
 44" x 335#,  
36" x 925#

**7 Beam The Hard Way (X-X Axis)**  
 44" x 285#

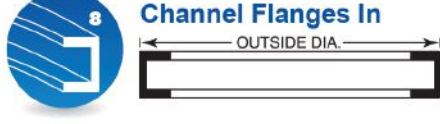
**8 Channel Flanges In**  
 All Sizes

**9 Channel Flanges Out**  
 All Sizes

**10 Channel The Hard Way (X-X Axis)**  
 All Sizes

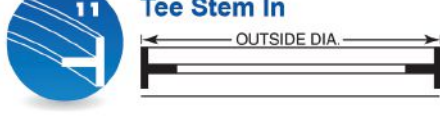
**11 Tee Stem In**  
 22" x 142<sup>1</sup>/<sub>2</sub># Tee

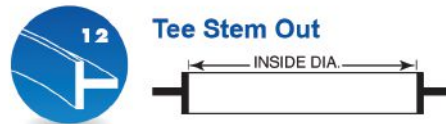
**12 Tee Stem Out** We bend ALL sizes up to:  
 22" x 142<sup>1</sup>/<sub>2</sub># Tee

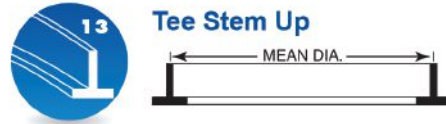
**13 Tee Stem Up**  
 22" x 142<sup>1</sup>/<sub>2</sub># Tee

**14 Angle Heel In**  
 8" x 8" x 1" Angle

**15 Angle Heel Out**  
 8" x 8" x 1" Angle

**16 Angle Heel Up**  
 8" x 8"x1" Angle

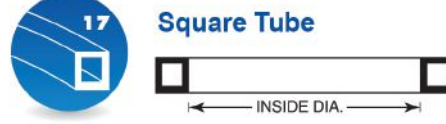
**17 Square Tube**  
 24" x 1/2" Tube

**18 Rectangular Tube The Easy Way (Y-Y Axis)**  
 20" x 12" x 5/8" Tube

**19 Rectangular Tube The Hard Way (X-X Axis)**  
 20" x 12" x 5/8" Tube

**20 Square Tube Diagonally**  
 12" x 5/8" Square Tube

**21 Round Tube & Pipe**  
 24" Sched. 80 Pipe

**22 Round Bar**  
 All Mill Produced Sizes

We also roll stair stringers, helical hand rails, off-axis bends, formed shapes and extrusions.

Visit [cmrp.com](http://cmrp.com) for more information.



**CHICAGO METAL**  
**ROLLED PRODUCTS COMPANY**

CHICAGO • KANSAS CITY







Stupp Bridge

A west-facing view of the bridge during steel erection.



Stupp Bridge

The valley and a river limited options for crane placement during steel erection.





Another view of the cross frames.

Stupp Bridge

KYTC received five bids for the bridge in November 2020, ranging from \$65.6 million to \$87.2 million. It awarded the project to the low bidder, Triton Construction. Triton selected Stupp Bridge to fabricate the girders to Palmer's original design. Although many challenges were encountered along the way, the Russell Fork crossing is a prime example of the versatility of steel and how projects can benefit from fabricator input early in the design phase.

**Owner**

Kentucky Transportation Cabinet

**General Contractor and Erector**

Triton Construction

**Structural Engineer**

Palmer Engineering

**Steel Fabricator and Detailer**

Stupp Bridge Company 



Turning an old rail spur bridge over the Russell Fork River into a vehicular bridge allowed for easier construction access.

Stupp Bridge





METALDECKSUPPLY.COM

METAL DECK...  
ANY SIZE. ANY PLACE. ANY TIME.



**Kevin Damron** ([kdamron@palmernet.com](mailto:kdamron@palmernet.com)) is a Senior Project Manager with Palmer Engineering. **Adam DeMargel** ([apdemargel@stupp.com](mailto:apdemargel@stupp.com)) is Senior Vice President of Sales for Stupp Bridge Company. **John Michael Johnson** ([johnm.johnson@ky.gov](mailto:johnm.johnson@ky.gov)) is the Project Manager for the U.S. 460 Project for the Kentucky Transportation Cabinet. **Brad Robson** ([brobson@palmernet.com](mailto:brobson@palmernet.com)) is a Principal with Palmer Engineering Company.

YOUR  
ONE-STOP  
METAL DECK  
SHOP!™



Largest Inventory  
In Stock for  
Immediate Use

Variety of Deck in Stock

15 Locations to Serve You

Project Management

Contact Us Today for the Best  
Service and Lead Time

METALDECKSUPPLY.COM

800-894-7741 · SALES@METALDECKSUPPLY.COM

# THE PROVEN STEEL BRIDGE DESIGN SOLUTION

**FREE  
15-DAY  
TRIAL\***

\*see website  
for details



The leading software package  
for designing and rating curved  
and straight steel girder bridges.

**Used by Many State DOTs and Top Design Firms**

(573) 446-3221 ■ [www.mdxsoftware.com](http://www.mdxsoftware.com) ■ [info@mdxsoftware.com](mailto:info@mdxsoftware.com)



# Banking on Steel

BY PAUL CONSTANTINI, SE, PE,  
GREG MARTIN, PE, AND  
MARY STANZIONE, PE



**CITIZENS BANK PARK** in Philadelphia has boasted one of Major League Baseball's biggest and brightest video boards since it opened in 2004.

Staying on the cutting edge of in-stadium displays occasionally means upgrading them, which the park has done thrice since 2004. And each time, the Philadelphia Phillies have aimed big with their home venue's video board.

The initial version of the board (also called PhanaVision) was primarily used for giving in-game statistics. After seven years in service, a new HD scoreboard replaced the original board during the 2010–11 offseason. That board measured 76 ft

high by 97 ft wide, approximately three times the size of the previous board and, at the time, the second-largest HD screen in the National League.

The Phillies decided in the spring of 2022 that it was time, once again, to redo the video board. And again, they proposed a dramatic size increase. They engaged longtime design partner EwingCole, which designed Citizens Bank Park, to determine the maximum size video board that the existing structure could support. Before the behemoth could be built and erected at that size, though, EwingCole needed to conduct numerous engineering studies.



Installing a larger video board at Philadelphia's Citizens Bank Park required extensive research on the existing support structure before any construction began.



Philadelphia Phillies

left: The new board during a Philadelphia Phillies game.  
below: The old board.



EwingCole

To determine a maximum display board size, existing steel framing and foundations needed to be reviewed and evaluated for increased gravity loads and present-day wind loads over the increased wind area. In addition, the studies needed to include provisions for a new enlarged sign containing the Phillies name and logo above the scoreboard display.

The steel support structure is not just comprised of the video board; it's essentially a building that supports various video display modules in addition to electrical and mechanical equipment required to operate the scoreboard. One of the main left-field light towers is also interconnected with the structure.

The primary framing for the existing scoreboard and light towers consists of four structural steel laced "box columns" that are interconnected with horizontal and vertical trusses. The primary framing members in the box columns vary in size, from W14×311 sections at the base of the light towers to W14×193 at the top, all ASTM A572 Grade 50. Two box columns extend to 149 ft above the main concourse, while the other two extend higher to 200 ft to support one of the left-field LED sports lighting arrays.

The scoreboard is supported by a series of catwalks that cantilever 4 ft off the field side of the main structure. A metal panel enclosure, which is roughly 16 ft deep, exists behind the full height of the scoreboard



A model of the video board's steel structure.

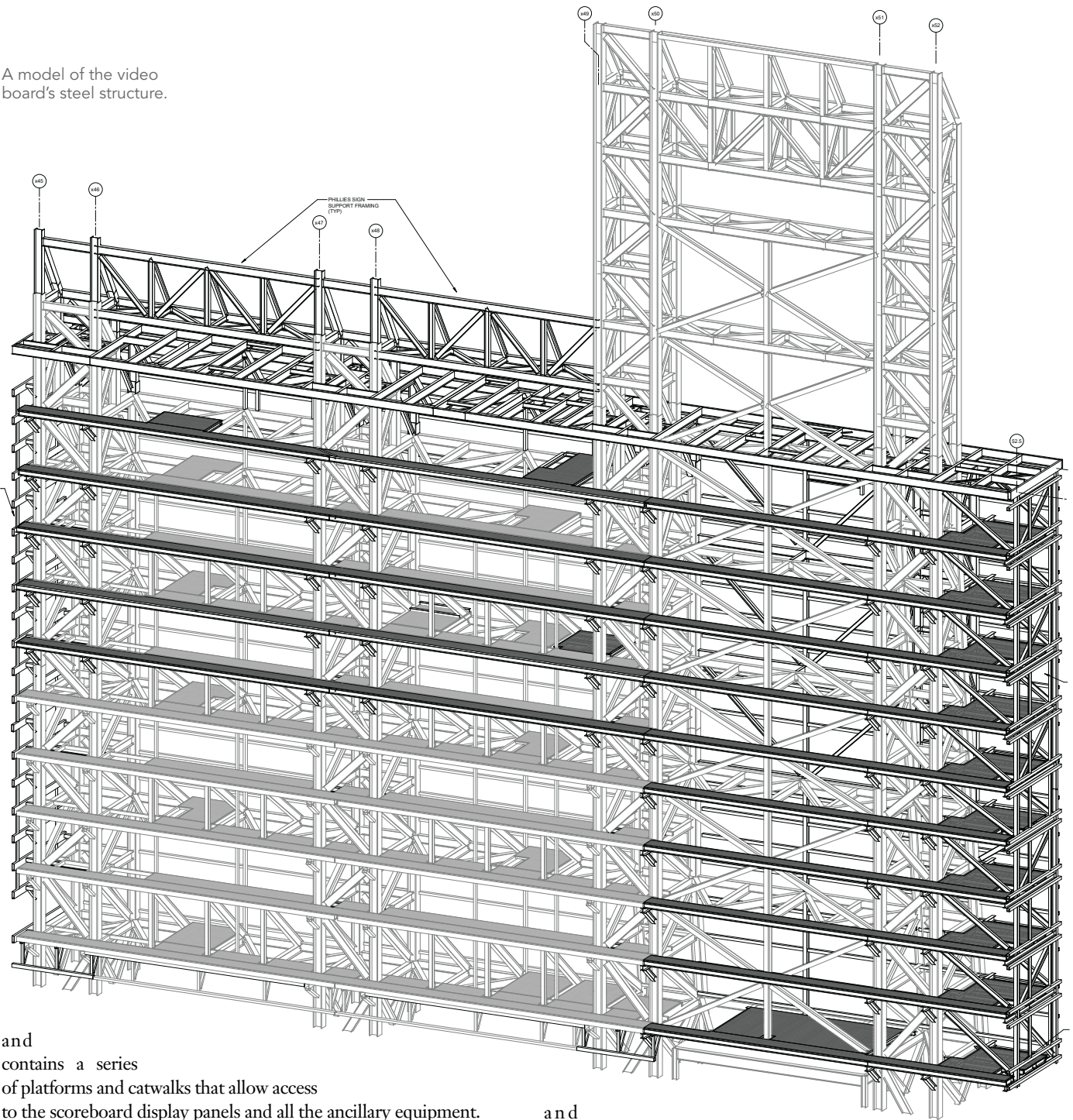

and contains a series of platforms and catwalks that allow access to the scoreboard display panels and all the ancillary equipment.

The display board size increments were iterated based on preset aspect ratios for the optimal video display. Studies for the expansion began with an extensive research effort to obtain shop drawings for foundations and steel framing from the original ballpark construction. The shop drawings were compared to original construction documents to confirm as-built framing sizes and steel connection information. In addition, original structural analysis models for the existing laced box column towers created in Bentley's STAAD structural analysis program were accessed and reused to help evaluate the original design gravity and lateral forces to accelerate 3D modeling.

Once existing foundation and member utilization ratios were determined, the video board size iterations were input into the models to determine the maximum size that the framing could safely support within its serviceability parameters. After several iterations

and analyses, the team found the maximum scoreboard size with the Phillies name and logo above that the existing structure could handle: 116,300 lb and 152 ft by 86 ft.

Finding the size was only part of the project. Next, the structural team needed to create a framework to support the new display and extensions from the existing framing.

The new support skeleton required extensive vertical and horizontal expansion beyond the limits of the current display support scheme. The support for the enlarged board mandated a new space truss comprised of wide flange chords, web members, and double-angle diaphragm bracing to cantilever more than 12 ft beyond the east end of the existing box column structure for the left-field lighting tower.



In addition, the two leftmost box columns were extended vertically by 9 ft using W14×61 (ASTM A992 Grade 50) sections to accommodate the increased height of the scoreboard and the new logo. The team generated a 3D model with Bentley STAAD that included catwalks and a cantilevered space truss. Additional 2D models were generated for the two sides of the box columns perpendicular to the wind load.

The analysis models indicated that some of the existing scoreboard support catwalks needed to be reinforced to meet more stringent deflection requirements for the new display. The maximum permitted vertical deflection was  $L/400$ , or  $\frac{1}{2}$  in., and the maximum horizontal deflection under short-term loads was  $L/240$ . Additional catwalks were designed to support the increased width and height of the scoreboard. The catwalks are metal grating supported by horizontal trusses with W8×35 chords and W8×15 and L4×4 web members. The trusses bear on W8×31 outriggers with W×24 braces to the existing columns.

More than 400 existing bolted and welded superstructure connections needed to be evaluated to determine if the demand/capacity ratios remained within acceptable limits. The original construction steel shop drawings were studied to obtain as-built connection details. The design team determined that most original connections did not align with available scenarios within connection design software capabilities. Therefore, a combination of software analysis and hand calculations were required to determine connection capacities and limit states.

.....

The new video board.

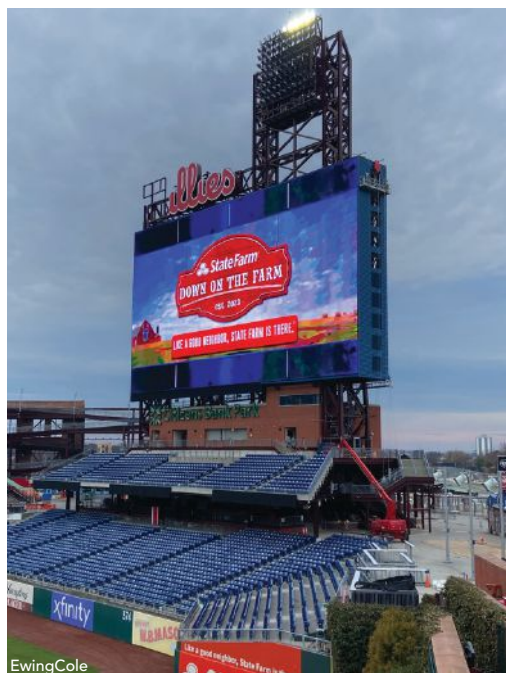

EwingCole

The video board's steel structure.

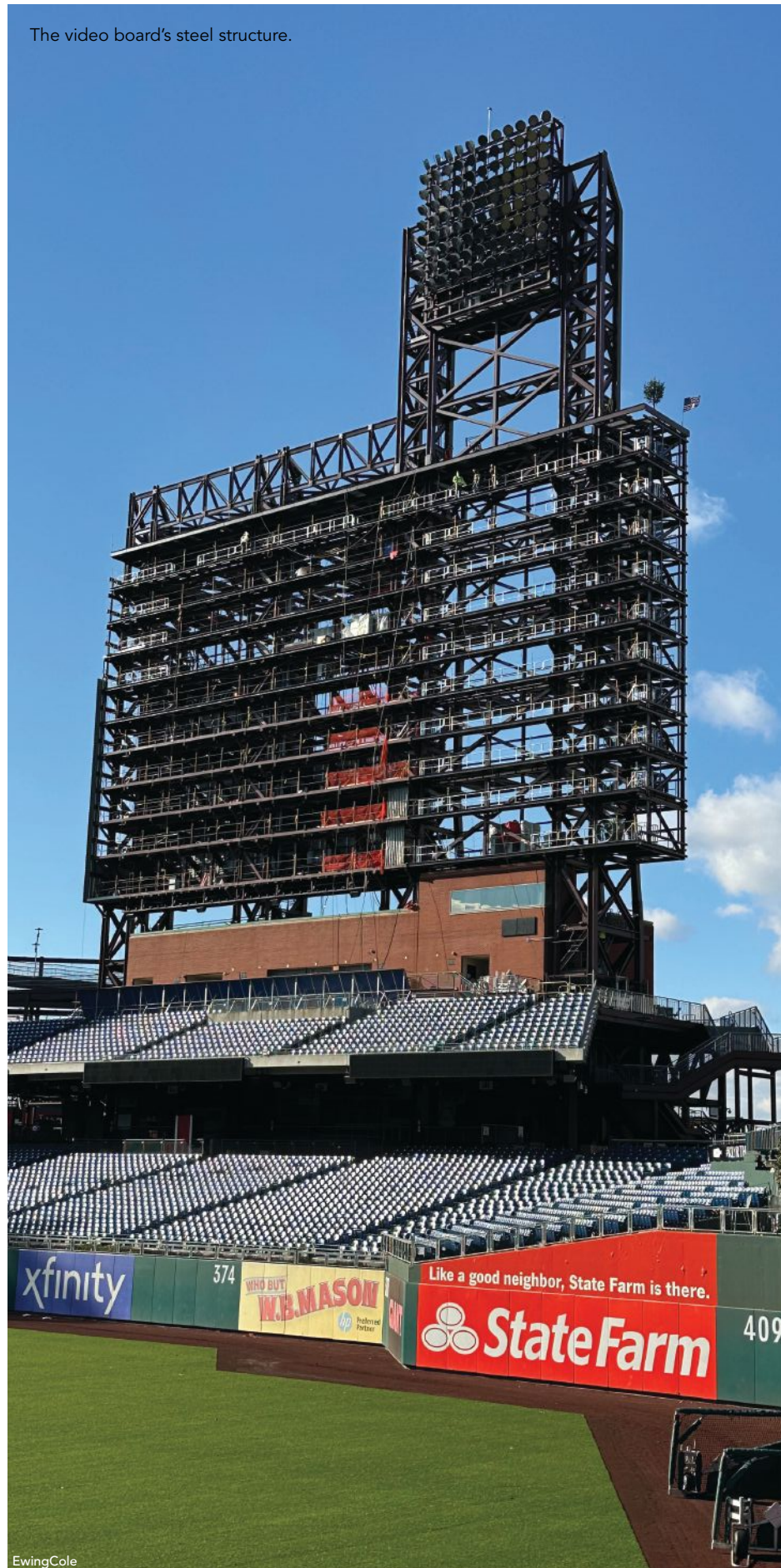

EwingCole



A detailed video board connection drawing.

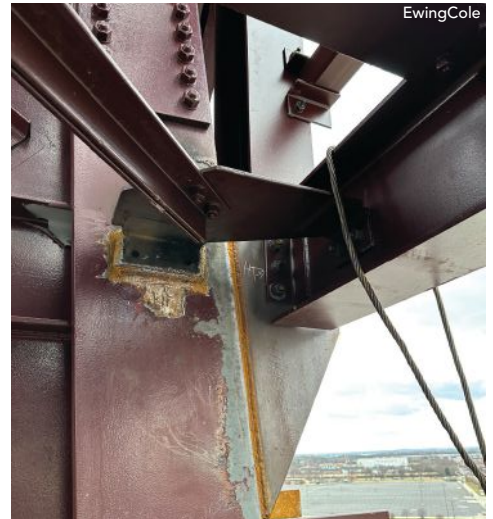
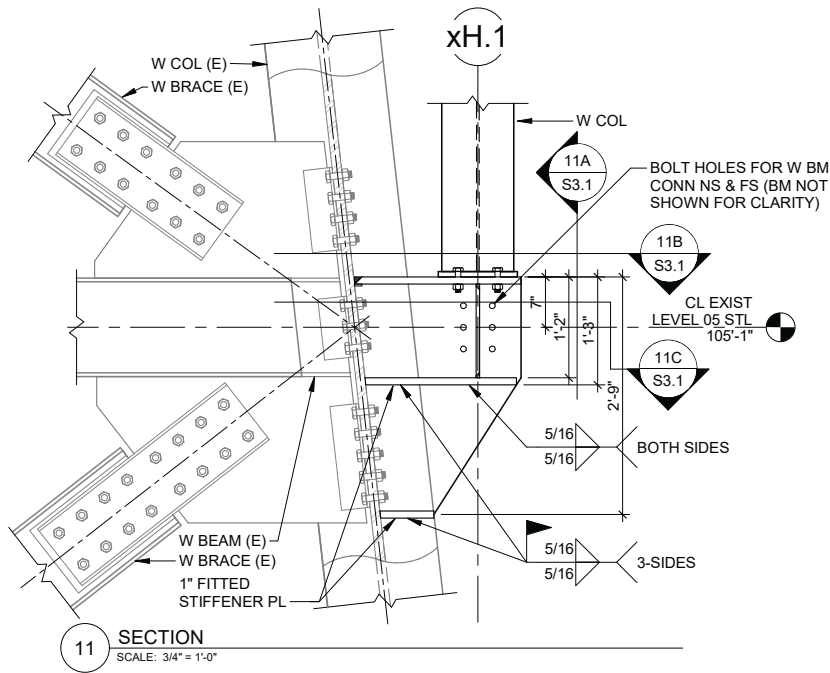

Some sloping areas of the existing frame were straightened to extend the video board beyond the last column of the existing structure.

Some connections needed reinforcement for certain conditions and needed to be designed. The existing column baseplates for the laced box column towers, anchorage, pedestals, and foundations were all evaluated for the increased loads and found to be adequate.

Because of the unique geometry and connection conditions created by the expansion, most new steel connections were designed and documented on the construction documents. EwingCole engaged fabricator Berlin Steel early to provide feedback on preferred connection types, and many of the comments were incorporated prior to final construction drawing issuance with the goal of speeding up the construction process.

Construction on the modifications was slated to begin in the 2022–2023 offseason, which was shortened from six months to five when the Phillies advanced to the 2022 World Series. While Phillies fans reveled, the design team pivoted. The tight schedule required an expedited shop drawing and RFI review process. To accommodate the abbreviated construction and field erection schedule, Berlin Steel, EwingCole, and general contractor LF Driscoll developed creative design modifications that allowed for more pre-fabrication in the shop and a more modular erection process in the field.

The altered plan was especially impactful for the center field end of the scoreboard, where the new support structure cantilevers beyond the east end of the existing laced box column structure of the LED sports lighting array. EwingCole provided multiple splicing options to Berlin, allowing most of the eastern framing to be prefabricated and erected as assemblies called “cubes.”





The ten cube modules measured 12 sq. ft by 8 ft tall and are mostly comprised of W8x28 posts with W8x24 horizontal members and W8x18 diagonals. Pre-fabricating the cubes minimized the number of crane picks and enabled ironworkers to complete most of the connections in the shop or on the ground prior to erection.

During construction, 1,126 bolt holes were field drilled and 11,700 field bolts were installed. More than 10,000 in. of fillet welds, 896 in. of partial or complete penetration groove welds, and 1,460 in. of flare-bevel groove welds were also installed. The welding alone is estimated to have taken 114 worker days to complete.

Even after the World Series run slashed six weeks of a six-month construction schedule, the new 116,300-lb board was unveiled in March 2023, just in time for

Opening Day. The new display, manufactured by Daktronics, can produce graphics in HD 4k quality and is 77% larger than the prior board.

The latest board measures 152 ft wide and 86 ft tall and is again one of the largest in MLB. In addition to a new video display, the size of the new Phillies logo and name above the existing scoreboard was increased and raised to the top of the new board. The existing structure gained 190 tons of structural steel to accommodate the new display.

There are zero bad seats at Citizens Bank Park, and the new PhanaVision brings the game closer to fans no matter their view.

**Owner**

Philadelphia Phillies

**General Contractor**

LF Driscoll

**Architect and Structural Engineer**

EwingCole

**Steel Fabricator, Erector and Detailer**

Berlin Steel 



**Paul Constantini**

([pconstantini@ewingcole.com](mailto:pconstantini@ewingcole.com))

is a principal and the director of structural engineering, **Greg Martin** ([gmartin@ewingcole.com](mailto:gmartin@ewingcole.com))

is a principal, and **Mary Stanzione** ([mstanzione@ewingcole.com](mailto:mstanzione@ewingcole.com)) is a structural project engineer, all with EwingCole.



**ABL-100HS**  
Angle Line

The only angle & flat bar line holding the title for both toughest build quality and fastest speeds.

**Controlled Automation**

501.557.5109 | [www.controlledautomation.com](http://www.controlledautomation.com)

# Airport Overhaul

BY CHRIS ADAMS, PE, ISABELA GONZALEZ, PE,  
RICHARD HAIGHT, AND THOMAS LUTZA



## **PASSENGER TRAFFIC AT DENVER INTERNATIONAL AIRPORT** continues to surge past its original design capacity.

The airport—consisting of the Great Hall main terminal and three concourses—could accommodate up to 50 million passengers per year when it opened in 1995. In 2019, though, it welcomed 69 million passengers, with projections of reaching 100 million passengers by 2030. The increased passenger count necessitated recently completed concourse expansions and the ongoing renovations of the Great Hall main terminal, termed the “Great Hall Renovation Project.”

Phase 1 of the Great Hall Renovation Project, completed in 2021, renovated the center portion to create new check-in

spaces for United Airlines and Southwest Airlines. It created a more modern check-in experience and added more capacity to the terminal, increasing operational efficiency.

Phase 2, which focuses on the northwest corner of the terminal and opens in February 2024, introduces a new security checkpoint on Level 6 that will have 60% more capacity than the existing checkpoint on Level 5. It used 260 tons of steel to expand the terminal’s capacity, and every steel component was transported to the site and erected while the airport remained operational. The key piece of the project was extending Level 6’s floor area, which required a braced frame to moment frame conversion.





A balcony extension and frame conversion were the greatest challenges in remodeling Denver International Airport's Great Hall.

The Great Hall membrane roof

### Level 6 Slab Extension

Previously, Level 6 housed ticketing counters, which were relocated to other areas in the Great Hall. The new security checkpoint requires more floor area, vertical circulation, and lateral frame modifications to accommodate passenger circulation.

Level 6's existing floor area required an extension toward the Great Hall centerline to accommodate the new security lanes. That expansion added nine new bays of framing with more than 10,000 sq. ft of floor area by extending the existing balcony 38 ft east. Like the existing floor, the new floor framing consisted of slab-on-metal deck over composite steel framing with typical bays of wide-flange girders supporting wide-flange beams at equal spacing.

Provisions for future phases of construction were incorporated into the new framing design, including a box girder stub that will eventually support a 70-ft bridge between the east and west extensions of Level 6.

One of the biggest challenges was finding suitable locations for new hollow structural section (HSS) columns to support the new Level 6 framing. The space beneath Level 5 is occupied by the baggage handling system (BHS) and the Automated Guided Transit System (AGTS), which transports passengers to and from the concourses. Placing a column through either would not be possible without major disruptions to airport operations.

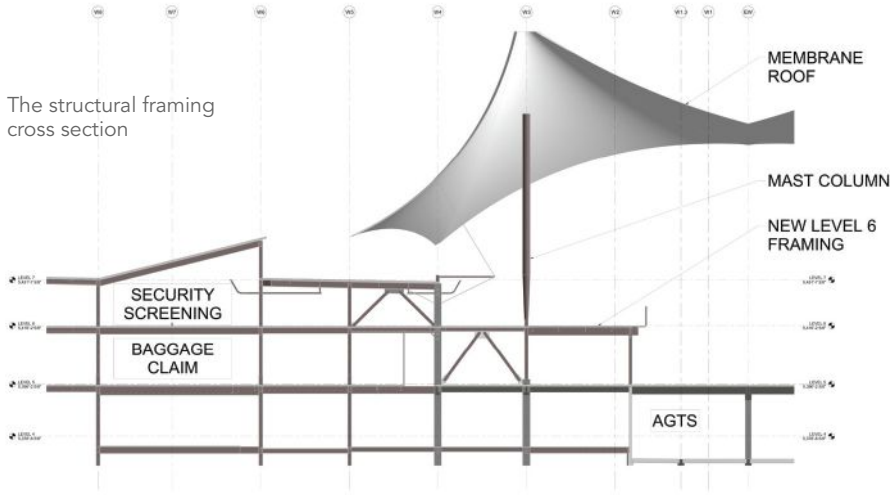

The structural framing cross section

The only suitable option was to support the new HSS columns on an existing 1-ft-thick cast-in-place concrete wall that runs north-south and separates the BHS from the AGTS. The existing wall has sufficient capacity to support the new HSS column loads. It can transfer the loads to the existing drilled piers, likewise with sufficient capacity, avoiding the need for costly new foundations.

### Braced Frame to Moment Frame Conversion

Existing braced frames behind the original ticketing counters braced the primary structure against wind, seismic, and sustained lateral demands from the membrane roof cable tensile forces.

The Great Hall's membrane roof—reminiscent of Rocky Mountain peaks and Native American teepees—shelters passengers from Colorado's climate. It's a prestressed, tent-like structure that uses high-strength fabric supported by an intricate system of steel cables and mast columns that form the peaks in the roof system.

The cables have pre-stress forces of up to 300,000 lb and are supported vertically by the Level 7 composite steel framing in most areas and laterally by steel braced frames at Level 6 in each direction. These



The security checkpoint rendering (above) and the finished security checkpoint (below).





**CONSTRUCTION SEQUENCE**

- 1) INSTALL REINFORCING BEAMS
- 2) PLACE CONCRETE AROUND EXISTING COLUMNS
- 3) INSTALL TEMPORARY BRACES
- 4) REMOVE EXISTING BRACES
- 5) INSTALL REINFORCING BEAMS
- 6) PLACE CONCRETE AROUND EXISTING COLUMNS
- 7) REMOVE TEMPORARY BRACES

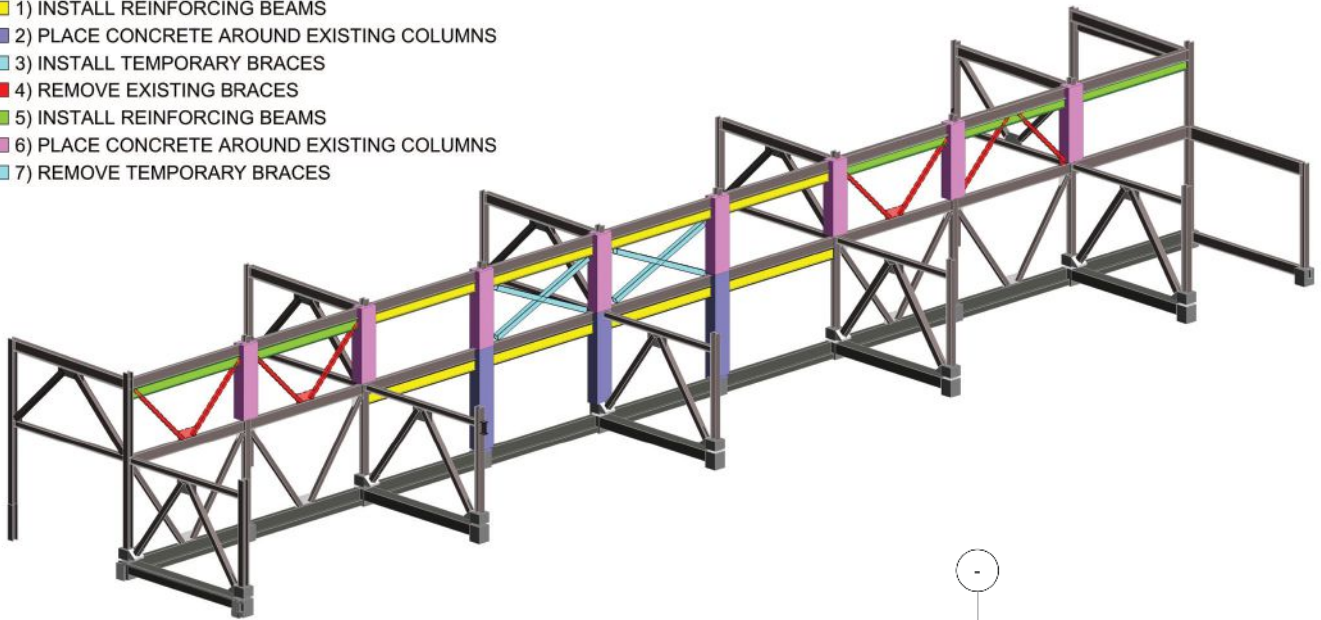

above: A diagram of the braced frame to moment frame conversion sequence

right: Composite column and sister beam detail

frames also brace the primary structure against wind and seismic forces.

Some existing braced frame elements in the north-south direction needed to be removed and converted into more open moment frame configurations to allow for passenger circulation through the new security checkpoint. Since the membrane roof reacts against the existing Level 6 braced frames, it was imperative to match the strength of the existing system and the frame stiffness to ensure the membrane roof behaves as initially designed.

To achieve an equivalent stiffness, the moment frame beams were created by sistering wide-flange beams below existing beams, both at existing braced frame locations and at additional bays. Shims of varying thickness were welded between the bottom of the deflected existing beams and the top of the new, flat wide-flange beams. Existing steel column flexural stiffness was increased by encasing the existing W14 columns in a 30-in. by 44-in. concrete section.

Welded rebar was used to transfer the end moments into the concrete column section at the Level 7 and Level 6 beam-column connections. Access to the top flange was limited at Level 7, though. Steel “tomahawk” plates with rebar dowels were welded to the underside of the top flange of the existing beam. The unique plate shape was geometrically necessary for the top flange rebar dowels to clear the flanges of the reinforcing beam below and properly transfer forces into the column.

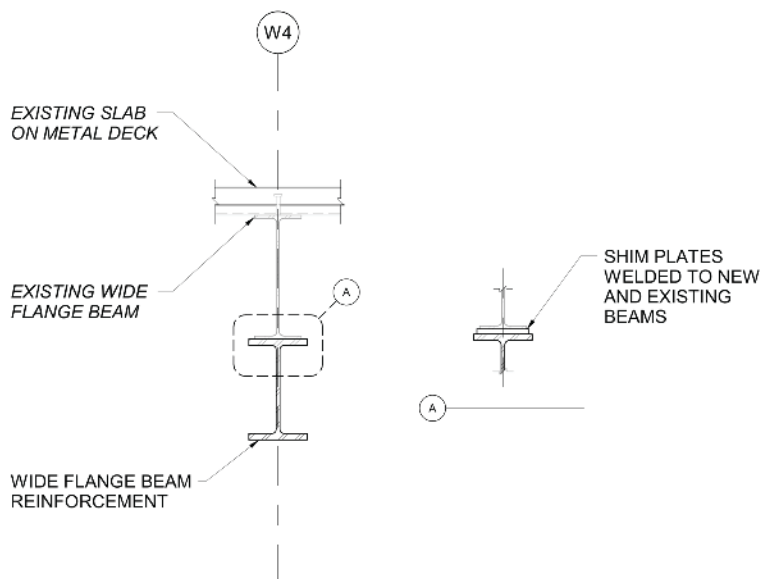
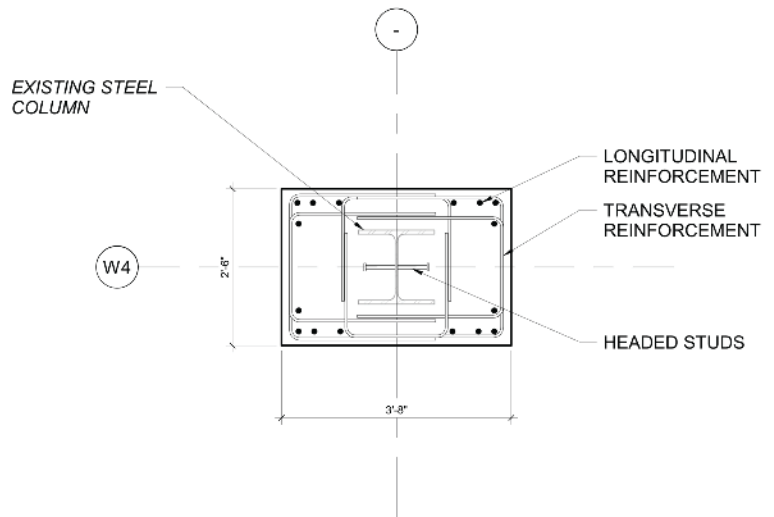

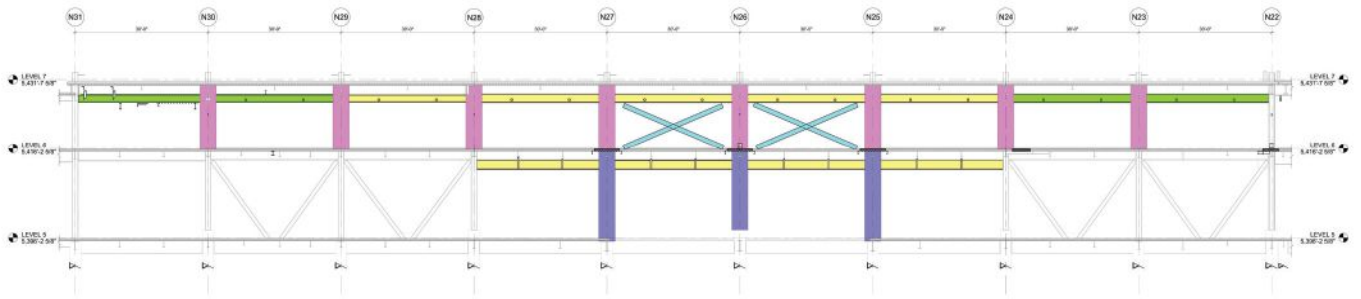

above: The braced frame to moment frame conversion diagram

left: Composite column detail

**NOTES:**

- 1) WIDE FLANGE COLUMN NOT SHOWN
- 2) CONCRETE COLUMN TIES NOT SHOWN

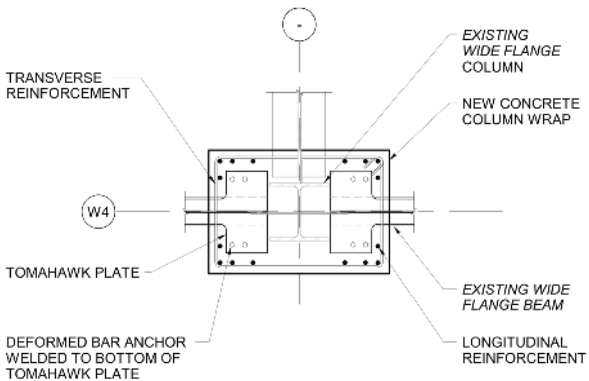
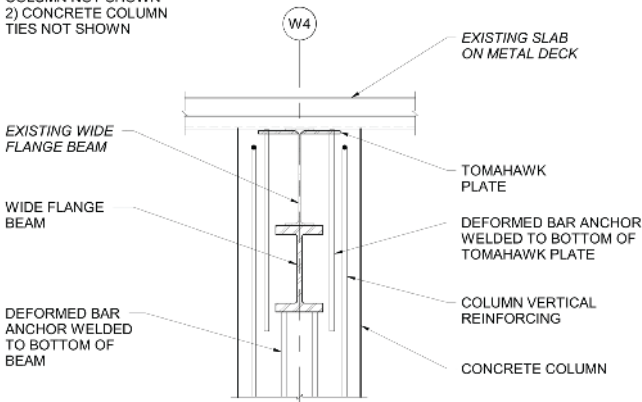

**NOTES:**

- 1) WIDE FLANGE COLUMN NOT SHOWN
- 2) CONCRETE COLUMN TIES NOT SHOWN

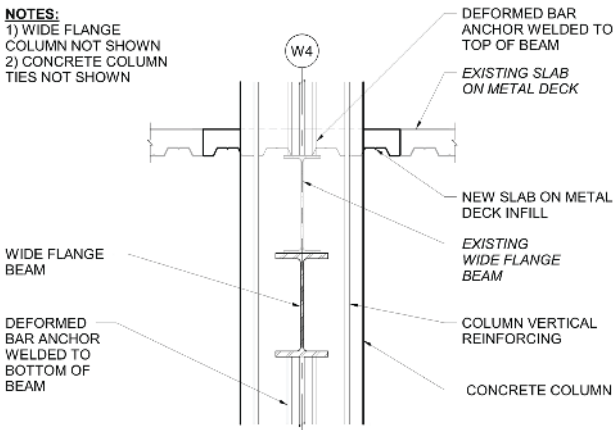

## Construction Sequence and Erection Challenges

Construction of the lateral frame modifications was one of Phase 2's biggest challenges. A complex construction sequence was necessary to ensure the system's stiffness was maintained throughout construction to keep the airport operable and to provide consistent support for the permanent membrane roof cable loads. Here is the construction sequence in the north-south direction:

1. Reinforcing beams were installed at the locations uninhibited by existing braces (yellow)
2. Concrete columns were then poured below Level 6 (purple)
3. Temporary braces were installed (blue)
4. Four existing braced frames were removed (red)
5. The remaining reinforcing beams were installed (green)
6. Concrete columns were poured below Level 7 (magenta)
7. The temporary braces were removed (blue), creating the final condition.

Completing a major renovation inside an operating airport presents steel delivery and erection challenges. Structural steel pieces were delivered to the terminal via the curbside parking structure. From there, each piece was rolled into the terminal using a cart or trailer pulled by a light piece of equipment. Travel paths in some locations of the terminal were reinforced to support the point loads from equipment during this operation.

If pieces were light enough, travel through unreinforced sections of the existing slab-on-metal deck was permitted. A large spider crane with a 13,000-lb pick capacity helped erect most of the steel in Phase 2, including the slab extension. The spider crane was supported on spreader beams on the existing Level 5 precast framing. Luckily, the existing precast framing was designed for a 250 psf live load and had the capacity to resist construction loading.

Each piece of steel was evaluated for its weight and length to determine if it could be safely wheeled into position and lifted into place. Steel erector Total Welding used gantry cranes, chain hoists, and other methods in areas where the spider crane could not reach.

Martin/Martin worked closely with the general contractor, fabricator, and erector to determine splice locations for members that were either too large to transport through the terminal or too heavy to lift into place with the equipment limitations in each area.





Courtesy of flydenver.com

The triple escalator rendering (above) and elevation (below) NEW ESCALATORS

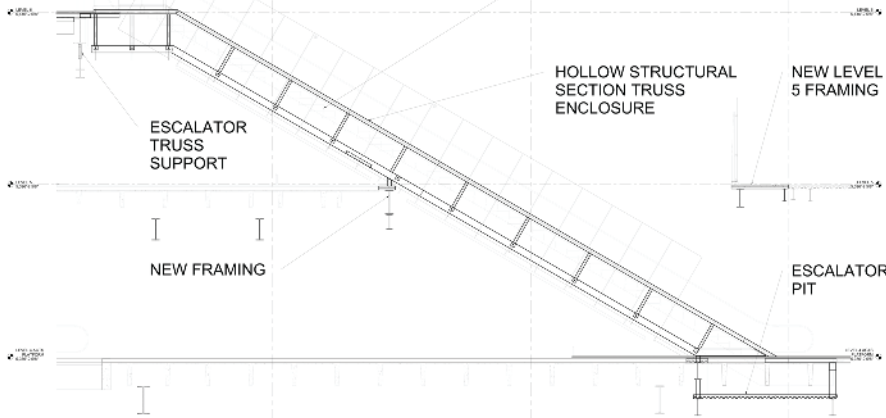

## Vertical Circulation

Moving the security checkpoint from Level 5 to Level 6 required new vertical circulation to transport passengers down to Level 4, the lowest level of the terminal and the access point for the AGTS.

A three-pack escalator that runs from the existing pedestrian connector bridge at Level 6 to Level 4 was installed through new openings cut in the existing Level 5 precast framing. Additionally, for passenger safety, the three-pack escalator was enclosed by a storefront system on each side supported by a HSS Vierendeel truss. The Vierendeel trusses live immediately outside the escalators and, along with the escalators, are supported at Levels 4, 5, and 6.

At Level 6, the existing pedestrian bridge truss framing could support the reactions from the escalators and truss enclosure and did not require strengthening. Shims leveled the escalator system on the deflected, existing truss structure.

Openings in the Level 5 precast framing were supported by a series of wide-flange beams spanning to existing precast columns. On the opening's north side, the new wide-flange beam supporting the opening also supports the escalators. At Level 4, new escalator pit framing was installed using wide-flange beams spanning to existing pier caps, which had adequate capacity to resist the new escalator loading.

The completion of Phase 2 construction marked the halfway point in the Great Hall Renovation Project. The remaining construction phases are ongoing or in design, with completion expected in 2028. The Great Hall's expanded capacity and improved circulation from Phase 2 will help the airport support its steadily increasing passenger volume long before the entire project is completed. ■

### Owner

City and County of Denver

### Architect

Stantec

### General Contractor

Hensel Phelps

### Structural Engineer

Martin/Martin, Inc. with subconsultants  
HCL Engineering and San Engineering

### Steel Team

#### Fabricator

Pikes Peak Steel, LLC 

#### Erector

Total Welding, Inc. 

#### Detailer

Anatomic Iron Steel Detailing 

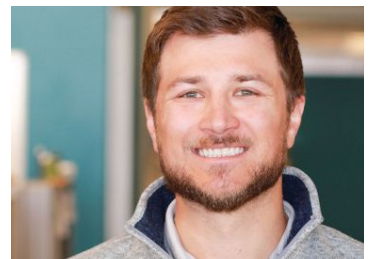

### Chris Adams

([CAdams@martinmartin.com](mailto:CAdams@martinmartin.com)) is an Associate and **Isabela Gonzalez** ([IGonzalez@martinmartin.com](mailto:IGonzalez@martinmartin.com)) is a Project Manager, both with Martin/Martin. **Richard Haight** ([RHaight@martinmartin.com](mailto:RHaight@martinmartin.com)) and **Thomas Lutza** ([TLutza@martinmartin.com](mailto:TLutza@martinmartin.com))

are Engineers-in-Training II with Martin/Martin.

# It's All About the NUTS AND BOLTS

**Hit deadlines and avoid delays with a coast-to-coast fastener partner that helps keep jobs moving forward.**

Lock down your fastener supply with a partner equipped to do whatever it takes to meet your deadlines and deliver high-performing products.

- ✓ Largest U.S. distributor and manufacturer of structural bolts and hardware
- ✓ Rush delivery on structural bolts and hardware
- ✓ Fast turnaround times on anchor bolts
- ✓ Jobsite assistance
- ✓ Expert support throughout the purchasing process



**Visit us at Booth 1430 during NASCC: The Steel Conference  
March 20-22.**

Scan the QR code to explore our structural steel industry solutions.



# Special Steel

BY JAMES PAWLIKOWSKI, SE

Hybrid structural systems can create a striking visual, but only if a meticulous and layered design process is done well.

**MANY TALL BUILDINGS** utilize concrete for their primary lateral systems and structure, either because of building usage, local practices, or the benefits of adding mass to a tall structure. However, some elements of these buildings—such as spires, crowns, connecting elements between multiple towers, and cantilever features—are often best constructed with steel.

The two can coexist—usually in the form of a significant steel structure erected on the top of a tall concrete building. But that process creates many challenges with the design and erection of the steel structure and how it impacts the base structure. Often, the erection strategy will dictate the detailing of the structure and influence its design, as will dictums for erecting steel hundreds of feet above the ground. Project construction sequences and their impacts and how to engage with the concrete structure are important considerations as well.

Choosing a steel structure for certain elements goes beyond the construction benefits that steel can potentially offer. Steel often allows for an architectural expression or massing that can be difficult or impossible to accomplish using concrete. The choice to use steel for these feature elements can be as much about providing aesthetic and spatial experience as efficiency and constructability. As with all solutions, a balance between aesthetic, function, cost, and construction must be achieved, which for these feature structures, means evaluating and accommodating the impacts to the rest of the building.

That evaluation starts with understanding the loading imparted on these types of features: wind, seismic, fatigue, and building maintenance and accessibility loading. Those can be as much, if not more, of a consideration than conventional gravity loading, and all may carry different considerations than for the base building structure. Additionally, the erection procedure can also create a dominant loading situation that can frequently control some of the steel structure's design. Creating an assumed detailed erection strategy at the early stages of the design is crucial.

Understanding the loading is only one important element to realizing these features. Another crucial one is developing the details that connect the steel element to the base building structure. Steel feature structures result in significant loading and reactions at the concrete structure—loading that cannot be accommodated by simply using conventional steel-to-concrete details such as embedded plates.

Additionally, a considerable amount of fixity and stiffness is typically required at these connections. Two frequent solutions are to embed steel shapes within the base building concrete structure or to create steel jackets for these elements. Either can have a significant impact on the design and detailing of the concrete elements, resulting in potentially thicker or larger elements or additional bracing components. And both can affect the space's function and aesthetic.

Developing the connection details between the feature steel structure and the concrete base structure is also dependent upon the selected erection strategy. Details are often developed to facilitate the erection strategy, which can range from simply attaching individual members to the base structure to providing temporary staging areas to create or lift wholesale sections of the feature structure. An assumed erection strategy when designing elements is vital, but it's also important to select the contractor, fabricator, and erector early in the process so all can participate in the design direction of these elements.

Three case studies that illustrate the different processes and challenges of creating these feature steel structures will be covered in a presentation at 2024 NASCC: The Steel Conference.

Steel was the preferred material for each building's significant feature elements, even though concrete was the base building material. Adding the steel element to each required close attention to loading, detailing, and construction sequence considerations for the base building and the feature structure, especially because it is located at or near the top of a tall building. ■

*This article is a preview of the 2024 NASCC: The Steel Conference session "Hybrid Structural Systems: The Design and Erection of Significant Steel Structures on Top of Tall Concrete Buildings." To learn more about this session and others, and to register for the conference, visit [aisc.org/nascc](https://aisc.org/nascc). The conference takes place March 20–22 in San Antonio, Texas.*



**James Pawlikowski**  
([jpwawlikowski](https://jpwawlikowski.com))  
([@datumengineers.com](https://datumengineers.com))  
is a principal with  
Datum Engineers.

# A Nonconformance Walks Into a CAR

BY TIM DUKE

Through the nonconformance and corrective action process, an effective quality management system can acknowledge, address, and correct internal missteps as easily as outside ones.

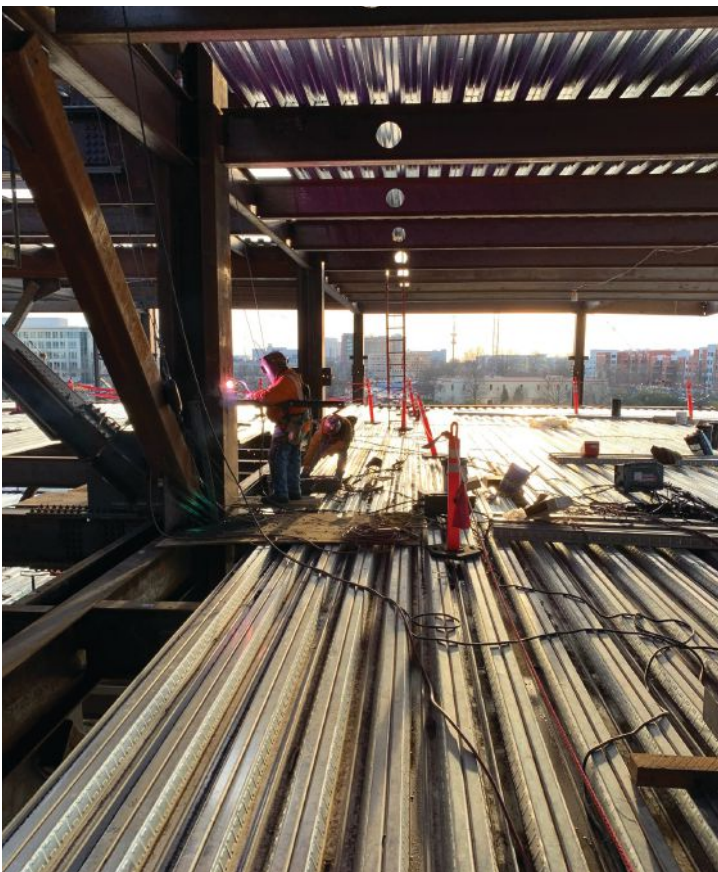

**WHEN I LEARNED** I had dealer's choice for my session topic at 2024 NASCC: The Steel Conference, I was excited at the possibility of finally breaking free from the bonds of predetermined destiny in public speaking scenarios.

I chose my topic relatively quickly, settling on nonconformances and corrective action requests (CARs). Why? Because so much of erectors' and fabricators' work is rigidly governed by design documents, specifications, and standards. Cataloging and resolving nonconforming work, though, is largely left to the creativity of enterprising individuals. And it's not easy.

A well-managed company knows it always has room for improvement. Individuals operate companies, and individuals are fallible. That's why quality management exists. Those who uphold and enforce it must know the company's objective, how it's supposed to be achieved, check the work, and resolving snafus before they impact anyone else. Identifying and resolving those bumps is tricky too.

The nonconformance process can be daunting, no matter the company or facility size. With all the moving parts, the procedure must be solid. *Standard for Certification Programs* (AISC 207-20) is a helpful guide with requirements to satisfy, but one business' best way of meeting them might not mesh with other companies' objectives and processes. The right path varies from company to company. Individual business' choices of the mechanisms that capture nonconforming work can encourage participation or pushback from involved parties.



Is the picture not quite in focus yet? Let's examine some items from the AISC 207-20 glossary:

**Corrective action:** The action or actions undertaken to identify and eliminate the root cause of a service or process nonconformance to prevent its recurrence. Corrective action is not the repair or rework of a nonconformance.

**Corrective measure:** The action taken to bring a nonconformance into conformance.

**Nonconformance:** Attributes of materials, consumables, fabricated work, manufactured components, erected members, or processes that do not meet contract, regulatory, or internally defined requirements.

I feel safe in assuming that fabricators and erectors with a record of nonconforming work are probably better at picking out others' nonconforming work before their own. It's far easier to pick out someone else's faults. Fabricator examples of nonconformance are plentiful: a mill order with pieces out of tolerance or subcontracted work (such as rolling or milling) that's not to specification. For an erector, nonconformed work could be mislocated anchor rods or incorrect bevels on fabricated members prepped for CJP welding.

Those missteps tend to stand out, and capturing them is as simple as sending a nonconformance report to the responsible party that points out the discrepancy and requests corrective measures. Remember, corrective measures are not the same as corrective action. Most contractors, especially those certified by AISC and audited by QMC, can likely show some external nonconformance records that directly impact our work.

Nobody needs binoculars to spot external flaws. A keen eye for others' mistakes should spark introspection: When you discover something you did incorrectly that qualifies as a nonconformance, do you capture it? Are you actively looking for internal nonconformances? Do you take them as opportunities to scrutinize your procedures, processes, and training's effectiveness in preventing them?

It's hard to elevate external nonconformances to CAR status. That's the responsible party's job, and only that party can do it. But investigating and unpacking internal nonconformances and elevating them to CAR status as needed can help any company solve systemic problems while encouraging employee participation.

My session will provide more tools to smoothen the bumps and bring employees and management into a quality improvement mindset. See you there! ■



**Tim Duke** ([tduke@weoga.com](mailto:tduke@weoga.com))

is a quality control and safety manager at Williams Erection Company and Atlanta Steel Erectors.



# You move a beam. BIM helps lighten the load.

Tighter margins, increasingly complex projects – succeeding in today's industry starts with integrated BIM workflows and seamless collaboration in the cloud.

With Autodesk, turn the most complex structural challenges into elegant, optimized solutions.



*Image courtesy of BNIM*



# NASCC: THE STEEL CONFERENCE 2024 EXHIBITOR LIST

(As of January 19, 2024)

## 3D Engineering Global LLC

**booth 1565**

Houston

**ph:** 346.459.6499

[www.3deglobal.com](http://www.3deglobal.com)

3DE Global provides world-class structural design, steel detailing, rebar detailing, precast concrete detailing, 3D laser scan point cloud data processing and BIM services. We use an array of licensed software and the latest cutting edge technology to provide turnkey solutions for our clients. We are a one-stop subcontractor for all of your engineering needs. Our team has extensive knowledge in residential, commercial and industrial projects. With branch offices around the globe and an experienced team of 126+ resources at our disposal, no job is to big or complicated for us to execute.

## AA Anchor Bolt, Inc.

**booth 1742**

Northville, Mich.

**ph:** 248.349.6565 | **toll free:** 800.929.3845

[www.aaanchorbolt.com](http://www.aaanchorbolt.com)

AA Anchor Bolt, Inc., a family-operated business founded in 1979. We manufacture a multitude of quality products for a global customer base, selling directly to the end user. The company produces anchor bolts, custom fasteners bent and threaded products from ¼–5 in. diameter, in various finishes and grades of steel, DOT, pulling irons, plates, manhole steps, barrier pins, round/square bent U-bolts, bracing rods, single/double-ended studs, etc. We carry a wide-range of products within our in-house facility and can create custom orders based on customer demand. Our motto is: “Impossibilities we do immediately. Miracles take a little longer.”

## Abrafast.com / The Blind Bolt Co.

**booth 1928**

[www.abrafast.com](http://www.abrafast.com)

## Accurate Perforating

**booth 2026**

Chicago

**ph:** 800.621.0273

[www.accurateperforating.com](http://www.accurateperforating.com)

Opened in 1942, family-owned and operated Accurate Perforating has grown from a small machine shop into a 210,000-sq. ft full-service perforated sheet metal supplier offering complete perforating, fabricating, and finishing solutions. Whether you need perforated aluminum, carbon steel, galvanized, stainless steel, brass, or copper in perforated sheets, coils, blanks, parts, finished components, or architectural metal, decorative metal, railings, facades, or sunscreens—with the broadest range of thickness, hole size, or pattern—we're the perforated sheet manufacturer you can trust. We specialize in custom and complex work. Made in Chicago.

## Acrow Bridge

**booth 1764**

Parsippany, N.J.

**ph:** 973.244.0080

[www.acrow.com](http://www.acrow.com)

Acrow has been serving the transportation and construction industries for more than 70 years with a wide range of modular steel bridging solutions for permanent, temporary and emergency use. Acrow's prefabricated modular solutions are designed and manufactured in the United States to the highest quality assurance standards in the world. Our versatile modular technology is engineered to accommodate a wide range of customizable lengths, widths and loads and our bridging components are hot-dip zinc galvanized, offering a service life of more than 100 years.

## Action Stainless & Alloys

**booth 1667**

Carrollton, Texas

**ph:** 972.466.1500 | **toll free:** 800.749.2523

[www.actionstainless.com](http://www.actionstainless.com)

Action Stainless & Alloys is a full-line fabrication center. We're stocked with a diverse inventory of stainless steel and aluminum products. From plate to pipe and everything in between, we specialize in being able to provide all the items on a bill of materials. Housing multiple cutting processes under the same roof means there isn't a cut or order request Action Stainless can't fill. Stop by to learn all of the capabilities of Action Stainless and discuss how we can help take your project to the next level!

## AFF Design Services Inc.

**booth 1153**

Dallas

**ph:** 559.567.3969

[www.affsteel.com](http://www.affsteel.com)

AFF came into existence in 2008 with the goal of becoming a premier detailing and connection design company in Dallas. We're connoisseurs in detailing and connection design, and we work tenaciously to deliver efficient results. With an ideology to succeed, our team of project managers, detailers and connection design engineers circles their guidelines around the requirements of our customers. Our innovative and comprehensive detailing procedures help us identify issues; this enables us to maintain the project schedule. Our methods have been tested and are proven to give effective outcomes.

Color Key:

Bridge Pavilion Exhibitor

Heavy Machinery Area

Safety Pavilion Exhibitor

## Agen – Robotic Structural Steel Assembler

**booth 116**

Atakum, Samsun

Turkey

**ph:** 90.362.502.1416

[www.abkaotomasyon.com](http://www.abkaotomasyon.com)

With the increased use of technology, using automation is becoming a must to meet the capacity/market needs. That's where we come in. We are your solution partner in making a permanent mark in your business. As Abka Automation Ltd., we design, manufacture and integrate fully automated Industrial 4.0 robotic structural steel assembly lines. With the aid of industrial robots, your products are becoming error-free and high-quality.

## AGT Robotics

**booth 313**

Trois-Rivieres, Quebec

Canada

**ph:** 819.693.9682

[www.agtrobotics.com](http://www.agtrobotics.com)

AGT Robotics is an automation and robotics expert specialized in the metal industry. They also manufacture the BeamMaster Weld, a robotic welding line specially engineered to answer all the welding needs of structural steel fabricators. BeamMaster features a small footprint, complete robotic automation and integration with dedicated software. With its attractive prices, all sizes of fabrication shops can now consider solving their welding production issues with robotic welding.

## AKS Cutting Systems

**booth 1058**

[aks-cutting.com](http://aks-cutting.com)

## Akyapak USA

**booth 633**

Bursa

Turkey

**ph:** 813.351.7100

[www.akyapakusa.com](http://www.akyapakusa.com)

Akyapak, one of Bursa's most established industrial enterprises, proudly exports metal bending, punching, cutting machines and welding solutions to 120 countries in six continents and delivers high quality from Turkey to the world. Akyapak, which is the source of pride of Bursa and Turkey with its technological production facilities with a total closed area of 32,000 m<sup>2</sup>, continues to lead the technology all over the world with its experienced production and management staff of 370 people.

## exhibitor list :: NASCC: THE STEEL CONFERENCE

### Albina Co. Inc.

**booth 1653**

Tualatin, Ore.

**ph:** 503.692.6010 | **toll free:** 866.252.4628

[www.albinaco.com](http://www.albinaco.com)

Are you in need of curved metal? Albina Co., Inc. has mastered the skills of steel and metal bending, rolling and fabrication. We bend and roll structural steel members, various sizes of round pipe and HSS material, and plate. We work with carbon, stainless, aluminum, and most exotic metals. We have serviced the steel industry since 1939 and we provide quality curved metal products and services that stand out from the competition. We make the most of the latest technologies in the field and can produce virtually any metal component that needs to bend or curve, and we can produce difficult and unusual parts.

### Allegheny Coatings

**booth 1665**

Ridgway, Pa.

**ph:** 814.772.3850

[www.all-coat.com](http://www.all-coat.com)

Allegheny Coatings is a premier metal protection applicator, providing zinc flake, zinc plating, zinc nickel plating, and related finishes. The company has locations in Pennsylvania and Indiana, stretching across the Eastern and Midwest U.S. Allegheny Coatings uses rack spray, dip spin, and electroplating processes to apply its coatings.

### Allfasteners

**booth 1659**

Medina, Ohio

**ph:** 888.859.6060

[allfasteners.com](http://allfasteners.com)

We supply quality fasteners of any type to a variety of industries. With decades of first-hand experience in the field, our knowledge provides a unique experience for our customers, every time—making us the place for all things fastening. We are not just fastener experts, though. Our steel fabrication capabilities have positioned us as a leader in the industry. Along with an extensive list of onsite, virtual and consumer based services, Allfasteners has cemented itself as a one stop shop for all industry needs. No matter the project, our goal is to find the solution to help you complete the job.

### Allied Machine & Engineering

**booth 122**

Dover, Ohio

**ph:** 330.343.4282 | **toll free:** 800.321.5536

[www.alliedmachine.com](http://www.alliedmachine.com)

Allied Machine & Engineering is a leading manufacturer of holemaking and finishing tooling systems. Allied devotes its advanced engineering and manufacturing capabilities to creating the widest selection of value-added tooling available to metal-cutting industries around the world. Our tooling solutions deliver the lowest cost-per-hole in a wide range of drilling, reaming, threading, boring and burnishing applications. Precision engineering and expert application support make Allied the first and best choice for solving complex metal-cutting challenges.

### All-Pro Fasteners, Inc.

**booth 1525**

Arlington, Texas

**toll free:** 800.361.6627

[www.apf.com](http://www.apf.com)

Precision fasteners engineered for structural steel construction. All-Pro Fasteners leads the industry in producing and supplying fasteners and associated products meticulously crafted to meet stringent ASTM standards. As a premier manufacturer and distributor, we specialize in construction bolts tailored for the structural steel sector. Our dedicated team of industry experts comprehends the specific demands of structural steel applications, overseeing every stage from production to quality testing and timely distribution. Count on us to deliver the exact products you require, precisely when and where you need them.

### Altair

**booth 1744**

Troy, Mich.

**ph:** 248.614.2400

[altair.com/architecture-engineering-construction](http://altair.com/architecture-engineering-construction)

Altair is a global leader in computational science and artificial intelligence (AI) that provides software and cloud solutions in simulation, high-performance computing (HPC), data analytics, and AI. Altair enables organizations in the AEC industry to compete more effectively and drive smarter decisions in an increasingly connected world—all while creating a greener, more sustainable future.

### American Galvanizers Association

**booth 2043**

Centennial, Colo.

**ph:** 720.554.0900

[galvanizeit.org](http://galvanizeit.org)

The American Galvanizers Association (AGA), headquartered in Centennial, Colo., is a not-for-profit trade association dedicated to serving the needs of specifiers, architects, engineers, contractors, fabricators, and after-fabrication hot-dip galvanizers throughout North America. Since 1933, the AGA has provided information on the most innovative applications and state-of-the-art technological developments in hot-dip galvanizing for corrosion protection.

### American Institute of Steel Construction (AISC)

**booth 1863**

Chicago

**ph:** 312.670.2400

[www.aisc.org](http://www.aisc.org)

The American Institute of Steel Construction (AISC) is a non-partisan, not-for-profit technical institute and trade association whose mission is to make structural steel the material of choice by being the leader in structural-steel-related technical and market-building activities, including specification and code development, research, education, technical assistance, quality certification, standardization, market development, and advocacy. AISC represents the total experience, judgment, and strength of the entire domestic industry of steel fabricators, distributors, and producers.



### American Punch Company

**booth 811**

Euclid, Ohio

**ph:** 216.731.4501 | **toll free:** 800.243.1492

[americanpunchco.com](http://americanpunchco.com)

The American Punch Company is the leading manufacturer of high-quality punches, dies, and shear blades for metalworking and structural steel fabrication. In addition, the company supplies precision tooling and custom die components to the stamping, roll forming and metal-forming industries. American Punch is proud to be ISO-certified, demonstrating a high level of commitment to quality in manufacturing and customer service. Quality tooling combined with superior customer service make American Punch the right choice for your tooling needs.

### American Steel Detailing, LLC

**booth 1937**

Medina, Ohio

**ph:** 330.241.4130

[www.americansteeldetailing.com](http://www.americansteeldetailing.com)

American Steel Detailing is an all U.S. structural and misc. steel detailing firm. ASD does projects all over the U.S. With a team of 15+ detailers, checkers and project managers, they are capable of completing projects large and small.

### American Welding Society

**booth 2114**

Miami

**ph:** 305.443.9353 | **toll free:** 800.443.9353

[www.aws.org](http://www.aws.org)

Founded in 1919, the American Welding Society is a nonprofit organization with a global mission: to advance the science, technology, and application of welding and allied joining and cutting processes worldwide, including brazing, soldering, and thermal spraying. By fostering knowledge, embracing change, and providing real-world opportunities through scholarships, fellowships, and workforce development, AWS provides the tools to help members succeed—and to inspire future generations of welding professionals.

### AMPP

**booth 2014**

Houston

**ph:** 281.228.6278

[ampp.org/home](http://ampp.org/home)

The Association for Materials Protection and Performance, AMPP, is the world's leading organization focused on the protection of assets and performance of materials. AMPP was created when NACE International and SSPC united after more than 145 combined years of corrosion control and protective coatings expertise, and service to members worldwide. AMPP is active in more than 130 countries and has more than 40,000 members.

Color Key:

Bridge Pavilion Exhibitor

Heavy Machinery Area

Safety Pavilion Exhibitor



### Anatomic Iron Steel Detailing

**booth 1645**

North Vancouver,  
British Columbia  
Canada

**ph:** 604.841.0555

[www.anatomiciron.com](http://www.anatomiciron.com)

Anatomic Iron Steel Detailing specializes in complex structural steel detailing, design detailing, connection design, design consulting and 3D modeling. We operate both Tekla and SDS2. We also complete steel erection animations and 3D rendering. Our team-oriented approach with our staff and clients has resulted in an outstanding track record of completing high profile complex projects accurately and on time. With over 300 staff, we can detail over 10,000 tons of structural steel per month. Please review our website at [www.anatomiciron.com](http://www.anatomiciron.com) or call 510.984.4425 to discuss our project history.



### Anthem Anchor Bolt and Fasteners, LLC

**booth 1561**

[www.anthemabf.com](http://www.anthemabf.com)

### Applied Bolting Technology, Inc.

**booth 1329**

Bellows Falls, Vt.  
**ph:** 802.460.3100

**toll free:**  
802.460.3100

[www.appliedbolting.com](http://www.appliedbolting.com)



We make Direct Tension Indicators, i.e., load cells, that assure compliance with bolting standards and specs. Torque, Turn of Nut, and TCs can all produce false positive tension, and regularly do: Torque scatter is  $\pm 40\%$ , for new bolts, and worse for weathered. Relying on torque is optimism, at best. TCs are torque bolts that are adversely affected by cold or wet weather. Turn of Nut can be defeated by mispresenting turn angle, regardless of turn applied. DTIs read load. If a bolt is tight, a DTI will show it, independent of weather, torque, angle, tool, or skill.

### ArcelorMittal International

**booth 1134**

Chicago

**ph:** 312.899.3051

[www.arcelormittal.com](http://www.arcelormittal.com)

ArcelorMittal is the leading supplier of quality steel products in all major steel markets, including construction. Signature products, like our HISTAR® (ASTM A913) steel, have been integral to numerous iconic structures, including One World Trade Center, 150 North Riverside, Mercedes-Benz Stadium, and SoFi Stadium. Through our world-class R&D team and outstanding distribution network, we offer innovative, competitive, and sustainable solutions that have led to several industry firsts, such as the 80-ksi rolled-steel shapes supplied in Chicago's Union Station Tower.

### Armatherm Thermal Bridging Solutions

**booth 1631**

[www.armatherm.com](http://www.armatherm.com)

### Arrow Reload Systems Inc.

**booth 2045**

Kamloops, British Columbia  
Canada

**ph:** 250.374.3831

[arrow.ca/reload](http://arrow.ca/reload)

Providing a superior gateway to your markets across North America, Arrow Reload Systems Inc. has offered best in class transportation and logistics services for over 100 years. Handling a broad range of products, we provide trucking, materials handling, freight management and consulting as well as technology solutions. Arrow Reload currently has 30 locations across North America with eight new locations added in the last few months alone. The Arrow Group of Companies are leaders in bulk commodity hauling, reload operations, freight management, logistics, consulting, and technology.

### Arteras Inc.

**booth 1830**

Duluth, Ga.

**ph:** 214.666.5167 x101

[arteras-inc.com](http://arteras-inc.com)

Arteras Inc. is a comprehensive structural steel detailing and engineering services company established by steel detailing professionals with more than 18 years of experience. Our business model focus on developing your structure with precision and quickness using intelligent resources such as Tekla Structures, AutoCAD, and SDS2. Arteras provides connection design services for all types of structural steel and miscellaneous steel.

### ASC Steel Deck

**booth 2061**

West Sacramento, Calif.

**ph:** 916.202.4391

[ascsd.com](http://ascsd.com)

ASC Steel Deck is a leading structural steel roof and floor deck manufacturer servicing the Western United States. As the only manufacturer on the West Coast to offer a full line of light-gauge structural products, ASC Steel Deck's extensive product offer meets the needs of the most complex conditions and demands for structural performance and design. The past two years, ASC Steel Deck has been focused on developing resources for engineers and architects. We have more resources and products to offer than ever before. Stop by and learn more.

### Association of Women in the Metal Industries

**booth 2065**

Mt. Royal, N.J.

**ph:** 856.423.3201

[www.awmi.org](http://www.awmi.org)

AWMI is an organization of professionals, founded in California in 1981, to promote and develop the growth of women in the metal industries. With 19 chapters in the U.S. and Canada, there is an event near you! The programs and activities of AWMI are intended to enhance members' skills and experience, address challenges confronting the industry, and promote members' career growth with the ultimate goal of increasing the number of women employed in the metal industries. Membership is open to both women and men. To learn more about AWMI and its four cornerstones (Network, Grow, Educate, and Mentor), visit [awmi.org](http://awmi.org).

### Atema Inc.

**booth 1728**

Chicago

**ph:** 312.861.3000

[www.atema.com](http://www.atema.com)

Atema specializes in building tailored AISC-compliant quality management systems for fabricators and erectors, while also offering quality assurance oversight on large bridge fabrication projects. We deliver specialized training and management assistance, guiding companies toward meeting the certification requirements of various infrastructure industry sector programs.

### ATF WORLD Inc.

**booth 1153**

[www.atfworld.com](http://www.atfworld.com)

### Atlas Tube, A Zekelman Company

**booth 1309**

Chicago

**toll free:** 800.733.5682

[www.atlastube.com](http://www.atlastube.com)

Atlas Tube, a Zekelman Company, is the leading manufacturer of steel hollow structural sections (HSS) and ERW straight-seam piling with seven manufacturing locations in North America. We provide an industry-leading size range with sizes up to 22 in. square, 28 in. round, and 34x10 in. rectangle, all with wall thicknesses up to 1 in. Our engineering team provides product education, connection insights, and answers to project-specific questions. Atlas products are readily available in industry standard and custom lengths, and extra-long lengths. Count on Atlas Tube for the products, services, and support you need to make your next project a success.

### Autodesk

**booth 2109**

San Francisco

**ph:** 415.507.5000

[www.autodesk.com/solutions/aec/bim/structural-engineering](http://www.autodesk.com/solutions/aec/bim/structural-engineering)

Autodesk is changing how the world is designed and made. Our technology spans architecture, engineering, construction, product design, manufacturing, media, and entertainment, empowering innovators everywhere to solve challenges big and small. From greener buildings to smarter products to more mesmerizing blockbusters, Autodesk software helps our customers to design and make a better world for all. For more information visit [autodesk.com](http://autodesk.com) or follow @autodesk.

### Automated Layout Technology LLC

**booth 201**

Hudson, N.H.

**ph:** 603.402.3055

[www.automatedlayout.com](http://www.automatedlayout.com)

Automated Layout Technology is the maker of the Lightning Rail, the first automated marking machine created specifically for the layout of stairs and hand rails. The Lightning Rail works with DXF files to quickly and accurately print an entire stair stringer or rail in minutes saving hours of labor. The fully automated CNC machine takes your design and prints the entire work piece on a rigid steel frame table in any configuration including rails, pickets, hangers and more. Easily place channels on the table for the automatic layout of stair stringers.

# exhibitor list :: NASCC: THE STEEL CONFERENCE

## AYARI LLC

**booth 1948**

Fulshear, Texas

**ph:** 336.337.7525

[www.ayariventure.com](http://www.ayariventure.com)

Houston based steel drafting services provider. AYARI will blow your BOLTS-OFF. (period) We are the blue-eyed boys for all steel fabricators seeking a drafting firm that carries integrity, competitive pricing, top-notch quality, a decade of experience, and great communication in their DNA. Strike a conversation with us at booth 1948. We can help make right decisions when it comes to steel detailing. No obligation and no BS.

## AZZ Metal Coatings

**booth 821**

[www.azz.com](http://www.azz.com)

## Baco Enterprises Inc.

**booth 1446**

[www.bacoent.com](http://www.bacoent.com)

## Bamal Fastener Corporation

**booth 1754**

[www.bamal.com](http://www.bamal.com)

## Be Pro Be Proud, Inc.

**booth 2332**

[www.beprobeproud.org](http://www.beprobeproud.org)

## Beamcut Systems / Machitech Automation

**booth 232**

St-Marc-des-Carrieres, Quebec  
Canada

**toll free:** 833.232.6288

[www.beamcut.com](http://www.beamcut.com)

For over 20 years, Machitech has offered fully customizable cutting systems of the highest quality. Choosing Machitech means gaining free lifetime access to our team of experts, specialized assistance, and prompt technical support. Join us at booth #232 to see our Beamcut Robotic Plasma Cutting System, an industry-leading robotic plasma cutting system that integrates advanced FANUC robotics & easy-to-use 3D simulation software with Hypertherm's XPR300 plasma systems. We will also show our Diamond Cut 5-axis CNC Plasma Table, equipped with a Hypertherm XPR300 plasma system, and our Deburring Tumbler.



Color Key:

Bridge Pavilion Exhibitor

Heavy Machinery Area

Safety Pavilion Exhibitor

## Bend-Tech

**booth 119**

Osceola, Wis.

**ph:** 651.257.8715

[www.bend-tech.com](http://www.bend-tech.com)

Bend-Tech is a leading provider of production-ready technology for tube and pipe processing to structural steel fabrication shops, and small to large manufacturers. Bend-Tech's A400 and A250 CNC plasma cutters and integrated software are versatile by design to fabricate a wide range of material length and profiles. For more than 20 years, Bend-Tech has improved the accuracy and efficiency of tube and pipe production for more than 30,000 fabricators and manufacturers around the world. Headquartered in Osceola, Wis., the company is a member of SEMA, PRI, NOMMA, NASCC, and NATM.

## Bentley Systems, Incorporated

**booth 1409**

Exton, Pa.

**ph:** 610.458.5000 | **toll free:** 800.BENTLEY

[www.bentley.com](http://www.bentley.com)

Bentley Systems (Nasdaq: BSY) is the infrastructure engineering software company. We provide innovative software to advance the world's infrastructure—sustaining the global economy and environment. Our industry-leading software solutions are used by professionals, and organizations of every size, for the design, construction, and operations of roads and bridges, rail and transit, water and wastewater, public works and utilities, buildings and campuses, mining, and industrial facilities. Bentley Systems employs more than 4,500 colleagues in 186 countries.

## Birch Hill LLC

**booth 1649**

The Woodlands, Texas

**ph:** 832.680.5525

[birchhillco.com](http://birchhillco.com)

We are delegated design engineers. We developed Samara™ for the intelligent design of structural steel connections. Samara is a cloud-based library of configurations. It is designed for professional engineers and detailers to make compliance and approval easy. Request a demonstration today!

## Birmingham Fastener

**booth 1430**

[www.bhamfast.com](http://www.bhamfast.com)

## Blackstone Group Technologies

**booth 2023**

[www.bgtek.com](http://www.bgtek.com)

## Blair Corporation

**booth 1630**

[www.blairwirerope.com](http://www.blairwirerope.com)

## Blast Cleaning Technologies

**booth 651**

[www.bct-us.com](http://www.bct-us.com)

## Blockpad

**booth 2159**

New Orleans

**ph:** 985.502.2957

[blockpad.net](http://blockpad.net)

Blockpad is calculation software re-imagined for engineering. Create custom calculation documents in a word processor interface, using spreadsheet style equations displayed in math notation.

## Bluebeam

**booth 1023**

Pasadena, Calif.

**ph:** 626.788.4100 | **toll free:** 866.496.2140

[www.bluebeam.com](http://www.bluebeam.com)

Trusted by over 3 million individuals in more than 165 countries, Bluebeam's smart, intuitive solutions advance the way building professionals work, manage and collaborate on projects digitally. Precisely detail, mark up, and review steel plans with our easy-to-use tools, ensuring smooth fabrication and erection. Founded in 2002 in Pasadena, Calif., Bluebeam has offices across the globe and a deep understanding of the steel industry's needs. Bluebeam is part of the Nemetschek Group. Download a free 30-day trial on our website and see how Bluebeam can revolutionize your projects fostering trust and efficiency across the project lifecycle.

## BlueRecruit

**booth 2245**

Clayton, N.C.

**ph:** 619.733.1392

[bluerecruit.us](http://bluerecruit.us)

BlueRecruit is a direct-hire marketplace for skilled-trade workers wanting to build their careers and the companies seeking their talent. The average blue-collar job requires four times more hard skills than white-collar jobs. However, the recruiting system for each industry is virtually the same. That is why BlueRecruit removes the inefficiencies of resumes and job posts and focuses on the skills and experiences that matter. Our clients see an average decrease of 74% in their hiring costs, and three times more job seeker connections than the industry standard. 83% of customers connect with at least one qualified job seeker the day they get started.

## Boss Tables

**booth 751**

[www.bosstables.com](http://www.bosstables.com)

## Bosworth Steel Erectors, LLC

**booth 2052**

Dallas

**ph:** 214.371.3700

[www.bosworthsteel.com](http://www.bosworthsteel.com)

Throughout Texas—and around the U.S.—Bosworth Steel Erectors has demonstrated our ability to deliver steel construction solutions for even the most difficult commercial construction projects. As a family-owned business, we hold to the values of treating clients with integrity and honesty. These simple tenets of good business, too often neglected within the construction business, are at the core of how we approach estimating, pre-construction planning, and building a team of professionals that can be assured when it matters most.



## Brainstorm Infotech

**booth 2005**

Bangalore, Karnataka  
India

**ph:** 91.99.8082.2911

**www.brainstorminfotech.co.in**

Brainstorm Infotech is headquartered in Bengaluru, the start-up capital of India. It has carved a niche for itself in the field of structural steel detailing and allied services with a credit of completing over 2,500 projects so far. Their expertise lies in structural steel detailing and connection design as per AISC, CISC, IS, BS and Australian standards for commercial and industrial structures with 2D and 3D advanced modelling software. Our dedication and commitment signify the trust and respect that we have from our clients and we continue to passionately collaborate with prestigious clients from North America and build a better future.

## Brown Strauss Steel

**booth 1345**

Aurora, Colo.

**ph:** 303.371.2200

**toll free:** 800.274.0359

**www.brownstrauss.com**



Brown Strauss is the premier structural steel service center in the U.S. We have the deepest inventory for your wide flange beam, structural tube, pipe, structural channel, structural angle and your other structural needs. Brown Strauss has over 120,000 tons of structural steel on the floor ready for next day delivery. Since our founding in 1905 we've grown to ten locations serving 24 states, and we're proud to be 100% employee-owned.

## Bryzos

**booth 1660**

St. Louis

**ph:** 844.427.9967

**www.bryzos.com**

Bryzos is the fastest growing digital marketplace in the metals industry with an extensive network of buyers and sellers. Bryzos has built the first instant pricing and procurement tool for the industry, facilitating the instant trade of carbon, stainless, and aluminum products. Aptly named the Gone In Sixty Seconds™ application, you can purchase or sell your commodity metals in sixty seconds or less using our free desktop or mobile application. This is the fastest metal trading experience ever made... and we can prove it. Don't believe us? Download it for free and check it out at [www.bryzos.com](http://www.bryzos.com).

## Bull Moose Tube Company

**booth 1547**

Chesterfield, Mo.

**ph:** 636.537.2600 | **toll free:** 800.325.4467

**www.bullmoosetube.com**

Bull Moose Tube produces Hollow Structural Sections (HSS) ranging from 1–14 in. square (and rectangular equivalents) in wall thicknesses up to 0.750 in.—creating value for a wide-range of applications. As one of North America's largest HSS producers, we're able to offer products that meet a variety of specifications including ASTM A500, A847, A1076, A1085, A1110, A1112 (up to 110 KSI), CSA G40 and EN 10219.

## Bureau Veritas North America

**booth 1826**

**www.bvna.com**

## CADeploy, Inc.

**booth 1225**

Danville, Calif.

**ph:** 408.375.9200 | **toll free:** 855.444.9497

**www.cadeploy.com**

CADeploy, Inc. (ISO 9001:2015) is a California corporation and member of AISC, NISD, MBMA, and ACI. We offer steel engineering, steel detailing, estimation services (structural steel/PEMB/rebar), and as-built services and HSE studies (oil and gas) to 400+ clients spread across the globe. Our team of 750+ engineers/personnel specializes in structural and miscellaneous projects across industrial, commercial, residential and other industries. We work on TEKLA, SDS2, Advance Steel, AutoCAD, RebarCAD, Revit, PDS, PDMS, and other widely used platforms. We have completed more than 3,200+ projects on time with 100% quality.

## Caldim Engineering Pvt. Ltd.

**booth 1860**

Chennai, Tamilnadu

India

**ph:** 044.4786.0455 | **toll free:** 248.455.3855

**caldimengg.com**

In the competitive landscape of steel detailing and connection design for the American steel construction industry, Caldium Engineering stands out as a beacon of excellence. With a winning combination of unrivaled expertise, cutting-edge technology, precision detailing, and client-centric principles, we continue to redefine industry standards. Choosing Caldium Engineering means choosing innovation, reliability, and a commitment to delivering exceptional results in every project we undertake. With 60 plus detailers on board using latest versions of SDS2 and Tekla, we shall be your best partner for steel detailing.

## CAMBCO, Inc.

**booth 1240**

Houston

**ph:** 713.781.9702

**www.cambcocinc.com**

CAMBCO—The original cambering machine since 1984! Cambco offers eight cambering machine models to fulfill any cambering requirement from small commercial buildings to highway bridges. We offer the complete cambering machine as well as a “Do it Yourself Hydraulics Kit” for each model. Conveyor fed and powered rollers also available on most models. Contact us for additional information. We are looking forward to hearing from you!

## Canam

**booth 1323**

Milford, Mass.

**ph:** 866.466.8769

**www.canam.com**



With over 60 years of experience and more than 300,000 projects, Canam's expertise is rivaled only by its ambitions. We specialize in designing and manufacturing steel joists and decks for the North American construction industry. Our distinctive BuildMaster collaborative approach is transforming building design and construction, offering up to a 20% reduction in erection time. Backed by a robust team comprising over 100 engineers and more than 650 structural steel detailers and drafters, Canam goes beyond being a mere supplier; we emerge as your ideal partner for achieving success.

## Cano Steel

**booth 2129**

El Paso, Texas

**ph:** 915.291.5125

**www.canosteel.com**

We have the equipment and qualified personnel for the installation of sheet in roofs, walls, mezzanines, acrylics, domes, as well as all kinds of accessories with high quality, safety, and speed. #GrupoCano

## Carboline

**booth 1364**

St. Louis

**ph:** 314.644.1000

**www.carboline.com**

Carboline manufactures high-performance coatings that extend the life of steel assets and passive fire protection materials that protect people and preserve structural integrity. Scientists in our world-class research, development, and innovation lab advance asset protection, and premier technical experts guide owners, engineers, and coating contractors to material solutions that accelerate construction schedules and deliver the best overall project value.

## Cascade Nut and Bolt Company

**booth 1704**

Salem, Ore.

**ph:** 503.375.6445 | **toll free:** 888.511.1005

**www.cascadenutandbolt.com**

Cascade Nut and Bolt Company is a full line fastener distributor specializing in structural bolting and anchors to steel fabricators around the country. We stock domestic, North American, and import structural bolts. We manufacture anchor bolts in house. We job pack for field bolt orders and excel at our paper work package. We are a stocking distributor of Infasco's INF 3013 coated bolts. We are a member of AISC.

## Cast Connex Corporation

**booth 1011**

Toronto, Ontario

Canada

**ph:** 416.806.3521 | **toll free:** 888.681.8786

**www.castconnex.com**

Cast Connex® is the industry leader in the architectural and structural use of cast steel components in the design and construction of building and bridge structures. Our products include pre-engineered connectors that simplify the design and enhance the performance of structures. We also offer design-build services for custom cast steel nodes and components.

**Cerbaco Ltd.**

**booth 1250**  
 Warrington, Pa.  
**ph:** 908.996.1333 x1  
[www.cerbaco.com](http://www.cerbaco.com)

Cerbacos line of 500+ configurations of non-metallic weld backings permit finished-quality, full-penetration welds from one side. They're for use with structural steel, shipbuilding, pipeline, pressure vessel, and tank manufacturing. Backings work with MIG, TIG, stick electrode, sub arc and flux core welding processes to weld carbon and alloy steel, stainless, and aluminum. Where one-sided welding is not desirable, backings eliminate arc gouging or heavy grinding prior to second-side welding.

**Chicago Clamp Company**

**booth 1440**  
 Broadview, Ill.  
**ph:** 708.343.8311

[www.chicagoclampcompany.com](http://www.chicagoclampcompany.com)

Chicago Clamp Company provides an innovative method for framing roof openings and supporting rooftop loads with no welding or drilling. This standardized method for connecting joists and beams allows structural engineers to focus on load distribution rather than attachment apparatus or welding concerns. With up to 4,000-lb capacity per system, it is ideal for the safe and economical framing and installation of rooftop units, sky lights, exhaust fans, and vents.

**Chicago Metal Rolled Products**

**booth 1122**  
 Chicago  
**ph:** 773.523.5757 | **toll free:** 800.798.4504  
[www.cmrp.com](http://www.cmrp.com)

Family-run since 1908, we work with our customers to bend and roll all steel grades, sizes and shapes including angles, bars, beams, channels, pipes, tubes, rail, sheet and plate. With two plants, 60+ rolling machines, and over 120 years of experience, our highly trained workforce and state-of-the-art equipment handle the most challenging jobs quickly with precision and accuracy. We have earned the respect of over 10,000 satisfied customers delivering 99% error-free tight bends holding minimal tolerances even for shapes with very complex geometries.



**Cleveland City Forge**

**booth 1516**  
 Wellington, Ohio  
**ph:** 440.647.5400 | **toll free:** 800.431.4350  
[www.clevelandcityforge.com](http://www.clevelandcityforge.com)

Cleveland City Forge, an innovative American manufacturing and engineering company, combines product development with production to produce standard and custom structural steel components that include forging, machining and distribution. Along with custom components, standard products include: clevises, clevis pins and recessed pins, turnbuckles, turnbuckles with fittings, threaded rods, rod ends, eye nuts, eyebolts, yokes, swage: sockets, sleeves, buttons and studs, and heavy hex nuts. Our products can also be grouped to create complete assemblies ready for installation.

**Cleveland Punch & Die Co.**

**booth 927**  
 Ravenna, Ohio  
**ph:** 330.296.4342 | **toll free:** 800.451.4342  
[www.clevelandpunch.com](http://www.clevelandpunch.com)

Cleveland Punch & Die Company is the world leader in manufacturing punches, dies and shear blades in the steel industry. All of our products are proudly manufactured in the U.S. Original equipment manufacturers continue to trust and recommend our products to meet and surpass our customers expectations for all steel applications. Our customers continue to trust and rely on the most experienced and friendly engineering and customer service support team in the industry. We are proud of our 144 years of quality, experience and tradition. Customer service hours: 7:00 a.m.–6:00 p.m. EDT; [sales@clevelandpunch](mailto:sales@clevelandpunch)

**Cleveland Steel Tool**

**booth 1808**  
 Cleveland  
**toll free:** 800.446.4402

[www.clevelandsteeltool.com](http://www.clevelandsteeltool.com)

Cleveland Steel Tool is the world leader in the manufacturing of punches, dies, shear blades and specialty tooling. Our punches, dies, shear blades and specialty tools are supplied daily to the structural steel, railroad (track and cars), farm equipment, truck frame, shipbuilding and grader blade industries, as well as serving all manner of fabricators and ornamental iron shops. In addition to the above, we also supply annular cutters, magnetic drills, portable punching units, steel saws and steel saw blades to the metal fabrication industry.

**Color Works Painting, Inc.**

**booth 1755**  
[www.ColorWorksPainting.com](http://www.ColorWorksPainting.com)

**Columbia Safety and Supply**

**booth 1941**  
 Columbia, Mo.  
**ph:** 800.969.5035  
[www.colsafety.com](http://www.colsafety.com)

Columbia Safety and Supply is North America's premier outfitter of safety gear, contractor equipment, and supplies. We are fall protection experts and we're here to help you find exactly what you need to be safe and productive. Our gear experts combine industry knowledge with professional experience. We service a variety of industries, including steel erection and fabrication, verticle concrete, building enclosure, road and bridge, and more. We carry thousands of products from the world's best manufacturers. Be safe, do more, with Columbia Safety and Supply!

**Combilift**

**booth 132**  
 Monaghan Co., Monahan  
 Ireland  
**ph:** 336.378.8884 | **toll free:** 877.266.2456  
[www.combilift.com](http://www.combilift.com)

As a specialist forklift and straddle carrier manufacturer, Combilift produces a wide range of customized handling solutions, all of which are designed for the safe, space-saving, and very productive handling of the long and bulky loads like those handled in the steel industry. The four-directional Combilifts work as counterbalance, sideloader, and narrow-aisle forklifts, with the Combi-SC (Straddle Carrier) being the cost effective solution for the handling of containers and oversized loads. Capacities across the Combilift range are from 3,200 lb. to 180,000 lb.

**COMSLAB**

**booth 1629**  
 Concord, Ontario  
 Canada  
**ph:** 905.738.9267  
[www.comslab-usa.com](http://www.comslab-usa.com)

COMSLAB is a long-span and shallow composite floor system that helps structural steel compete with the low floor-to-floor concrete designs. COMSLAB is a lightweight assembly that has UL listed exposed and unrestrained ratings of one, two, and three hours for spans of 30+ feet! It's ideal for all elevated floor construction such as hotels, schools, office, high-rise, multi-residential, and medical buildings. COMSLAB products are in compliance for NYC high rise and LA RR approvals.

**Con-Serv Inc.**

**booth 1628**  
 Georgetown, S.C.  
**ph:** 843.546.1044  
[www.con-servinc.com](http://www.con-servinc.com)

Your All-American structural bearing solution—structural support bearing systems for all industries. Con-Slide™ support bearing systems: type CSA and CSB, type CHP, high temperature bearings—bronze, Meehanite®, graphite, elastomeric bearings—Neoprene®, fabric reinforced, high load multi-rotational—pot, disc, spherical, radial and self aligning, rocker bearings and other specialty fabrications. Designed and fabricated to accommodate: thermal expansion, end-beam rotation, vibration isolation, and seismic acceleration.

**Controlled Automation, Inc.**

**booth 625**  
 Bauxite, Ark.  
**ph:** 501.557.5109  
[www.controlledautomation.com](http://www.controlledautomation.com)

Controlled Automation is a customer-driven company specializing in the design and manufacture of superior fabricating equipment. Our mission, as a team, is to strengthen and grow through the success of our customers while offering them constant respect, gratitude, and a quality product. Along with new machinery, we offer material handling systems to compliment each of our machines. All machines, software, and controls are designed, manufactured, and supported entirely in the U.S.

Color Key:

- Bridge Pavilion Exhibitor
- Heavy Machinery Area
- Safety Pavilion Exhibitor



**Copper State Bolt & Nut Co.**  
booth 1843

Phoenix  
ph: 602.27.2384 | toll free: 800.603.6887  
[www.copperstate.com](http://www.copperstate.com)

Copper State supports fabricators and erectors throughout the U.S. with product that ranges from structural fasteners, hex bolts, TC bolts, anchor bolts, double-end studs, and other manufactured specials. We support fabricators in their shop with tools and accessories, cutting tools, abrasives, safety products, and other industrial supplies. Copper State has 30+ locations in the western U.S. providing local support, and we are stocked heavily with structural inventory in Phoenix, Denver, Reno, Salt Lake City, and Spokane. Site support includes sequencing and logistics, product labeling and identification, online cert management, and VMI.

**Cordeck**  
booth 2051

Kenosha, Wis.  
ph: 877.857.6400  
[www.cordeck.com](http://www.cordeck.com)

Established in 1994, Cordeck is a family-owned and operated full-service, nationwide, manufacturer of high-quality steel decking and metal deck accessories. We pride ourselves on creating strong, long-lasting relationships with our customers. We will do "whatever it takes" to ensure the success of our clients, which is why we offer full project management and expert engineering services—we are with you from concept to completion. Cordeck is a Steel Deck Institute (SDI) member, fully certified to manufacture metal decking and our products meet FM and ICC-ES requirements.

**CoreBrace**  
booth 921

West Jordan, Utah  
ph: 801.280.0701  
[www.corebrace.com](http://www.corebrace.com)

CoreBrace buckling-restrained braces (BRBs) are a cost-effective solution to improve the seismic performance of structures. This highly ductile system has been used in thousands of projects worldwide for earthquake risk mitigation. CoreBrace's expert staff works closely with owners, architects, engineers, fabricators, and erectors to meet their design and construction requirements and is committed to providing braces to the highest level of quality. Our extensive research program focuses on sustainable and resilient designs of structures in high seismic zones.



**Crystal Clean**  
booth 1845

Hoffman Estates, Ill.  
ph: 630.333.5901  
[www.crystal-clean.com](http://www.crystal-clean.com)

Crystal Clean provides parts cleaning, used oil, hazardous and non-hazardous waste services to small and mid-sized customers in the manufacturing sector. Our service programs include parts cleaning, containerized waste management, used oil collection and vacuum truck services. These services help our customers manage their used chemicals and liquid and solid wastes. Our customers include large and small manufacturers.

**CSC – Canam Steel Corporation**  
booth 1235

Point Of Rocks, Md.  
ph: 301.874.5141 | toll free: 833.888.0545  
[cscsteelusa.com](http://cscsteelusa.com)

Canam Steel Corporation (CSC) is a service-oriented manufacturer of open web steel joists and steel deck that services the entire U.S. via our six manufacturing facilities. We are a company that prioritizes safety and efficiency of the entire process for both our employees and our customers. We believe in the power of partnerships and the need for flexibility throughout the process for all of our partners. Our projects range from the small retail store at a local strip mall to some of the largest distribution centers, high-rises, schools and stadiums. We are a participating member of both the SJI and SDI.

**CSM Metal Deck**  
booth 2012

Houston  
ph: 713.991.2202 | toll free: 800.229.4276  
[www.metaldocking.com](http://www.metaldocking.com)  
Metal Deck Manufacturing

**Cutting Edge Steel & Stair**  
booth 1947

Dacono, Colo.  
ph: 303.651.3180  
[cesteel.com](http://cesteel.com)

At Cutting Edge Steel, we have the knowledge and expertise to provide an affordable solution to all of your project stair and rail needs. We are your one-stop solution. Our specialty includes work across North America of architectural, commercial service, and industrial class stair and rail products. CES offers "pre-engineered" systems when applicable or can work with clients who envision a one off product for true uniqueness of ornamental design. Depending on scope and location CES can also provide a complete miscellaneous steel packages. Please call to discuss the needs of your next project.

**CWB Group**  
booth 1840

Milton, Ontario  
Canada  
ph: 800.844.6790  
[www.cwbgroup.org](http://www.cwbgroup.org)

CWB Group is an Ontario, Canada-based, industry-supported private sector not-for-profit organization that provides comprehensive, integrated services to nearly 10,000 companies and 100,000 professionals across the welding and joining industry in nearly 50 countries worldwide. EWI provides industrial manufacturers with advanced engineering services in materials joining, forming, testing, and modelling to create effective solutions in product design, fabrication, and production. The organization is based in Columbus, Ohio, and Buffalo, N.Y. Visit us at [http://ewi.org](http://http://ewi.org).

**D.S. Brown**  
booth 1746

North Baltimore, Ohio  
ph: 419.257.3561  
[dsbrown.com](http://dsbrown.com)

Founded in 1890, The D.S. Brown Company is a leading worldwide designer, supplier, and manufacturer of engineered products for the bridge, airport and highway industries. As technology has evolved and influenced our means of transportation, D.S. Brown too has evolved to meet the needs of the current times. From our humble beginnings to our current focus on the manufacturing of high-quality infrastructure construction products under Gibraltar Industries, D.S. Brown has been there for over a century to help the world move forward.

**DACS, Inc.**  
booth 1512

Portsmouth, Va.  
ph: 757.393.0704  
[www.dacsinc.com](http://www.dacsinc.com)

DACS, Inc., with a plant strategically located in Portsmouth, Va., manufactures roof and floor decking. Since 1987, DACS has been providing the construction industry with affordable products and quality services. Our continued growth is fueled by loyal customers and innovative products. With a full line of roof products, including deep decks and cellular decks, as well as composite and non-composite floor decks, DACS is sure to satisfy all your decking needs. Please note we also offer our products in carbon steel, stainless steel, and aluminum.

**Daito Seiki Co., Ltd.**  
booth 942

East Dundee, Ill.  
ph: 847.437.6788  
[www.daitousa.com](http://www.daitousa.com)

DAITO is focused on metal cutting, drilling and plasma cutting machines and has become the most technologically advanced machine producer in its field. Along with being the world's top manufacturer in its field, DAITO is geared toward customer satisfaction by supporting our customers with our knowledgeable and responsive sales, applications and our sales personnel.

**Danny's Construction Company, LLC**  
booth 1829

Shakopee, Minn.  
ph: 952.445.4143  
[www.dannysconstruction.com](http://www.dannysconstruction.com)

Since 1970, Danny's Construction Company has been an industry leader in complex and schedule-demanding steel erection projects. We have substantial experience in building bridges, sports and events facilities, hospital and medical facilities, as well as a variety of industrial and commercial structures. With this experience, we have built a reputation for surpassing rugged industry standards for quality, safety, and productivity. Strategic office locations across the country provide us the resources available to take on projects regardless of size, location, complexity, or demanding scheduling parameters.



## exhibitor list :: NASCC: THE STEEL CONFERENCE

### DAVI, Inc.

booth 1146

Addison, Texas

ph: 972.661.0288 | toll free: 888.282.3284

[www.davi.com](http://www.davi.com)

More than ever, applied technology is being called upon to solve manufacturing's quest for global competitiveness. The challenge is to locate the best technology and to gather it in one place for consultation. DAVI, unique in plate roll and angle roll industry, makes this available at our own U.S. customer support center, located in Dallas.

### DBM VirCon

booth 1613

[www.dbmvircon.com](http://www.dbmvircon.com)

### Delta Steel

booth 1015

Houston

toll free: 800.324.0220

[www.deltasteel.com](http://www.deltasteel.com)

Delta Steel is a customer oriented company, striving to build long lasting and mutually profitable customer relationships. We are committed to continuous improvement in our service, in our products, in safety and in our personnel. We emphasize professional and ethical business dealings with customers, suppliers and employees. Formed in 1963, Delta Steel is a subsidiary of Reliance Steel & Aluminum Co. Delta Steel is one of the largest steel service centers in the southwest U.S. serving industrial, commercial as well as OEM markets.



### DGS Technical Services, Inc.

booth 1145

Elgin, Ill.

ph: 630.539.8200 x5204

toll free: 630.539.8200 x5202

[www.dgsts.com](http://www.dgsts.com)

DGS Group is a client-centric and performance-driven organization offering end-to-end solutions in engineering, design, and structural domains, headquartered in Elgin, Ill. Our global footprint includes offices in the U.S., Canada, UK, and Gulf. With certified American PE and technical project managers boasting over 40+ years of experience, we leverage smart software like Tekla and SDS2. Our production team comprises highly skilled engineering squads dedicated to structural engineering, steel detailing, bridge detailing, connection design, estimation, and estimodeling.

### Dlupal Software, Inc.

booth 1204

Philadelphia

ph: 267.702.2815

[www.dlupal.com](http://www.dlupal.com)

Dlupal offers powerful programs for structural and dynamic analysis of multiple materials including steel, cold-formed steel, steel connections, concrete, aluminum, timber, CLT, glass, cables, and fabric form-finding per U.S./International standards. The 3D FEA program RFEM efficiently and accurately performs non-linear analyses of member, plate and solid elements. RFEM is one of the most highly sophisticated yet user-friendly programs especially suitable for new users with its intuitive modeling work flow. Experience why more than 5,000 companies and universities worldwide trust in Dlupal Software.

### Doerken Coatings

North America

booth 2008

Grass Lake, Mich.

ph: 517.522.4600

[www.doerken.com/us/en/](http://www.doerken.com/us/en/)

[doerken-coatings](http://doerken-coatings)

We at Doerken Coatings are specialists for high-quality surface protection, offering sustainable, customized solutions for a wide range of application areas. With innovative technologies such as zinc flake coatings, architectural coatings, zinc plating systems, coil coatings, and E-Coat, we offer high-performance corrosion protection for steel components and structures! Discover our coating expertise!

### DOT Quality Services

booth 1728

Chicago

ph: 312.285.5344

[www.dotqs.com](http://www.dotqs.com)

DOT Quality Services (DOTQS) specializes in developing performance standards and implementing supplier audit programs. Whether your need is for a comprehensive assessment of your entire supplier base or a focused audit of a single contract, DOTQS delivers reliable, quantifiable insights. Our team of experienced quality professionals and engineers leverage technical and quality system expertise to provide effective assessment services.

### DuraFuse Frames

booth 910

West Jordan, Utah

ph: 801.727.4060

[www.durafuseframes.com](http://www.durafuseframes.com)

The DuraFuse Frames Difference is adding resilience and economy to steel moment frame structures. Working with our engineering team and our prequalified field-bolted connection will reduce construction cost and add value for all project stakeholders. Utilize our complimentary design assist services to reduce the steel tonnage, simplify fabrication, shorten erection and add seismic resilience through repairability.

### Eastern Pneumatics &

Hydraulics, Inc./

McCann Equipment Ltd.

booth 1342

Salem, N.H.

ph: 603.893.7662 | toll free: 800.356.5624

[www.ephtools.com](http://www.ephtools.com)

EPH specializes in steel erector and torque tools such as: Tone, electric; TorqFusion, pneumatic, electric and battery; Torcup, SPX power team hydraulic wrenches, cylinders and pumps; Skidmore-Wilhelm bolt tension calibrator; Kabo torque wrenches and torque testers; Klein drift pins up to 1 $\frac{1}{16}$  in., structural wrenches and accessories. We operate an ISO 17025:2017 accredited calibration facility for repair, calibration and certification with NIST traceability. We also have the capability to service virtually any make and model torque tool.

### Edanbrook PE and

Detailing Services

booth 2110

Columbia, Md.

ph: 410.779.9546

[www.edanbrook.com](http://www.edanbrook.com)

Edanbrook Consultancy Services Inc. is a Maryland based engineering (PE stamping) and detailing company. Edanbrook provides all the engineering services and PE stamping under one roof. Edanbrook provides steel, precast and rebar detailing using Trimble Tekla, AutoCAD, SDS2 software. Whether you need point cloud scan, point cloud modeling, electrical drafting, connection design, DXF drawing, design and drafting, mechanical drafting, offshore structural detailing, piping design, structural steel detailing, structural drafting, material take-off and estimation, quantity survey, or shop drawings, we're your one-stop solution provider.

### EHS Momentum, LLC

booth 1844

Dallas

ph: 469.999.2500

[www.ehsmomentum.com](http://www.ehsmomentum.com)

We make life easier for safety teams by helping you integrate safety management into operations. Our state-of-the-art safety management software and industry-leading consulting will help you increase productivity. At EHS Momentum, our goal is to deliver simple, affordable, and proven environmental, health, and safety best practices to any size business.

### EMI

booth 1158

Green Lane, Pa.

ph: 610.287.4240 | toll free: 877.445.4292

[www.emiworks.com](http://www.emiworks.com)

Electro-Mechanical Integrators, Inc. is a manufacturer of CNC plasma equipment specializing in miscellaneous metals for the fabrication industry. We have been committed to providing cost-effective solutions through quality machines and unparalleled service for 25 years. Contact us today to see how our machines can save you time and make you money.

### ENERCALC

booth 1925

Missoula, Mont.

ph: 949.645.0151 | toll free: 800.424.2252

[enercalc.com](http://enercalc.com)

ENERCALC is a proven, powerful, widely-used design program consisting of 40+ structural calculation modules, ranging from simple component designs (steel beam, concrete column, etc.) to analysis (i.e., rigid diaphragm torsion), earth retention, and full 3D FEM analysis. ENERCALC's powerful capabilities and simple intuitive interface make it ideal for complete design of small and medium-sized structures, as well as for spot checks, verifications, and design of miscellaneous components on large-scale projects. NEW! Engineers can now create/manage calculations and update Revit models even faster via ENERCALC for Revit.



**Engineered Rigging**  
booth 1709

Valparaiso, Ind.  
toll free: 844.474.4448  
[www.EngineeredRigging.com](http://www.EngineeredRigging.com)

Engineered Rigging is a leader in heavy lifting. We solve project challenges by providing innovative rigging and specialized transport equipment rental and sales, in-house engineering expertise and trained equipment operators. Our sales and rental fleet includes hydraulic gantries and accessories; strand jacks; jack-up systems; knuckle boom cranes; slide, skidding and trolley systems; and more. If you need a custom solution, we can design and fabricate to your specific needs. Put our gear and knowledge to work for your next plant upgrade, maintenance or civil construction project.

**Enidine**  
booth 1725

Orchard Park, N.Y.  
ph: 716.662.1900 | toll free: 800.852.8508  
[www.itt-infrastructure.com](http://www.itt-infrastructure.com)

Our highly engineered structure protection components and custom solutions are built to take on whatever Mother Nature can dish out. With 20-plus years of experience, Enidine offers a diversified portfolio of energy absorption products for infrastructure and equipment protection. Enidine offers the fastest service in the industry, the highest quality of testing around and in-house product development. No matter what seismic protection solutions you need, we get the job done.

**EVER Seismic, LLC**  
booth 1331  
[www.everseismic.com](http://www.everseismic.com)

**Exact Detailing**  
booth 1433

Victoria, British Columbia  
Canada  
ph: 250.590.5244  
[www.exactdetailing.com](http://www.exactdetailing.com)

Exact Detailing is Canada's premier specialist in providing steel detailing, 3D modeling, BIM, and 3D scanning services to the North American steel industry. Our five offices across North America employ high-quality detailers trained in the most recent programs and processes to provide the best AISC and CISC compliant shop drawings on all varieties of steel projects. Need services beyond steel detailing? Ask us about our project management/coordination, connection design, data management, and surveying services. We pride ourselves the quality of our work and look forward to working with you!

Color Key:

- Bridge Pavilion Exhibitor
- Heavy Machinery Area
- Safety Pavilion Exhibitor

**Fabreeka International, Inc.**  
booth 1716

Stoughton, Mass.  
ph: 781.341.3655 | toll free: 800.322.7352  
[www.fabreeka.com](http://www.fabreeka.com)

Fabreeka values our working relationships with structural steel designers and builders. We have been known for more than 100 years to provide exceptional engineering knowledge, first-class customer service and high-quality products which include preformed fabric and random oriented fiber pads, slide bearings and thermal breaks. Our team recommends effective solutions for reducing structure-borne noise, thermal bridging and vibration for buildings, bridges, rail track, piping, machinery and more. Let's talk about your next project!

**Fabricating & Metalworking**  
booth 2126

Helena, Ala.  
ph: 866.832.8473  
[www.fabricatingandmetalworking.com](http://www.fabricatingandmetalworking.com)

Fabrication & Metalworking publishes 10 issues per year. Fabricating & Metalworking covers every aspect of metal forming and fabricating, welding, metal cutting, tooling and workholding, measurement and inspection, material handling, maintenance, and environment, health, and safety. Rely on us for cutting-edge product news and competitive operating solutions to help improve processes and product quality, equipment reliability, operator safety, and business profitability.

**Fabricators & Manufacturers Association**  
booth 124

Elgin, Ill.  
ph: 815.399.8700 | toll free: 888.394.4362  
[fmamfg.org](http://fmamfg.org)

The Fabricators & Manufacturers Association, International®, (FMA) is a professional organization with more than 2,500 individual and company members from North America and 20 other countries who work together to advance the metal processing, forming, and fabricating industry. Founded in 1970, FMA brings fabricators, metal producers, equipment manufacturers, and service providers together through professional development programs, industry-exclusive networking events, market-leading publications, meaningful volunteer opportunities, and FABTECH.

**FabStation by Eterio Realities**  
booth 1365

Colwood, British Columbia  
Canada  
ph: 778.557.8571 | toll free: 866.979.0453  
[fabstation.com](http://fabstation.com)

Eterio Realities is a software company, started by fabricators, focused on building production software for the fabrication floor. Our product, FabStation, is a cloud-based software suite that focuses on providing digital augmented reality tools that will help steel fabricators visualize and complete their work in a more efficient and accurate manner. Check out our product video or visit our website and see the future of production using the Microsoft HoloLens 2 with FabStation.

**Fabsystems, Inc.**  
booth 2031

Bethel, Minn.  
ph: 888.991.6911  
[fabsystemsinc.com](http://fabsystemsinc.com)

Fabsystems is a cloud-based steel estimating program. Our state-of-the-art steel estimating software is designed to streamline your steel fabrication and construction projects. Whether you're a small fabricator or a large construction company, our software is designed to meet your needs and help you take your business to the next level.

**FACCIN U.S.A. INC.**  
booth 451

Addison, Texas  
ph: 833.611.3676  
[www.facingroup.com](http://www.facingroup.com)

FACCIN Group is a leading global metal forming machine manufacturer that provides a wide range of plate rolls, angle rolls, dished heads line and special machines. FACCIN Group is the sole proprietor of FACCIN – ROUND and BOLDRINI brands. The FACCIN and ROUND solutions are suitable for bending different type of profiles (standard and non-standard) at very tight diameters and strict tolerances. Wide range of accessories and CNC controls are available with the aim to increase precision and productivity. FACCIN and ROUND angle rolls are the best solution for your next future challenges!

**FATZER AG**  
booth 1743

Pine Knoll Shores, N.C.  
ph: 252.904.6986  
[www.fatzer.com](http://www.fatzer.com)

FATZER produces uncompromising steel wire rope assemblies. Founded in 1836 as a rope-making factory on Lake Constance in the Swiss town of Romanshorn, FATZER has been manufacturing top-quality ropes for generations. In the early stages, hemp ropes were produced, with steel rope manufacturing starting around 1900. Today, FATZER specializes in developing, manufacturing, and globally distributing high-quality steel wire ropes for structural, ropeway, and other applications. With a long history of meeting specific market needs, FATZER is recognized as a leading rope manufacturer for stadium roofs, facades, bridges, and other applications.

**Federal Emergency Management Agency (FEMA)**  
booth 1853

Washington  
ph: 240.304.8292  
[www.fema.gov](http://www.fema.gov)

The FEMA Building Science Branch develops and produces multi-hazard mitigation guidance that focuses on creating disaster-resilient communities to reduce loss of life and property. Building Science develops publications, guidance materials and tools that incorporate up-to-date building codes, floodproofing requirements, seismic design standards, and wind design requirements for new and existing buildings. The National Earthquake Hazards Reduction Program is the federal government's approach to addressing earthquake risks. FEMA's role is to translate research and technology development, into effective earthquake risk reduction publications.

# exhibitor list :: NASCC: THE STEEL CONFERENCE

**Fenagh Engineering & Testing**  
booth 2036  
[www.fenaghengineering.com](http://www.fenaghengineering.com)

**FICEP Corporation**  
booth 425  
Forest Hill, Md.  
ph: 410.588.5800  
[www.ficepcorp.com](http://www.ficepcorp.com)

FICEP Corporation is currently the largest manufacturer of structural steel and plate fabrication systems and software. FICEP offers over 150 different CNC systems to achieve the optimum solution to any specific fabricators application. In addition to the different CNC work centers, FICEP totally integrates custom designed material handling systems for intelligent steel fabrication without the requirement for multiple operator involvement.



**Fickett Structural Solutions**  
booth 1955  
[www.fickettinc.com](http://www.fickettinc.com)

**Flame On, Inc.**  
booth 1748  
[flameoninc.com](http://flameoninc.com)

**Fontana Fasteners, Inc.**  
booth 1617  
Frankfort, Ind.  
ph: 765.654.0477  
[www.fontanagrupperoagntna.com](http://www.fontanagrupperoagntna.com)  
Fontana Fasteners, Inc., a Fontana Gruppo company, produces LE USA® fasteners and provides customers with high-quality cold-formed fasteners produced from steel melted and rolled exclusively in the U.S. In fact, Fontana Fasteners Inc. is the only North American full-service manufacturer and provider of structural bolts, nuts, washers, and TC assemblies.

**Gas Innovations**  
booth 1563  
La Porte, Texas  
ph: 817.229.2008  
[gasinnovations.com](http://gasinnovations.com)  
Gas Innovations has an impressive worldwide resume for successfully supplying high purity hydrocarbons worldwide for a vast array of applications and services. We are also a supplier of Kobelco flux-core and hard welding wire, propylene MACH 1 cutting and heating apparatus. Propylene has proven its productivity nationwide for more than 30 years in metalworking applications that include flame cutting, heating, (preheating and stress relieving), brazing, soldering, flame hardening and HVOF metalizing. The high flame temperature and the heat of combustion produced by propylene and oxygen produces cutting speeds 30% to 60% greater than natural gas.

Color Key:  
Bridge Pavilion Exhibitor  
Heavy Machinery Area  
Safety Pavilion Exhibitor

**GEKA USA**  
booth 743  
Abingdon, Md.  
ph: 410.319.2900 | toll free: 443.955.1007  
[www.gekaus.com](http://www.gekaus.com)

GEKA USA produces CNC lines and solutions for steel and metal working. Geka offers a large range of CNC solutions for structural steel and plate fabrication systems. These include ironworkers, CNC positioners and feeders, CNC solutions for drilling, and CNC solutions for punching; angles processing CNC punching solutions (GAMMA Series); flat bars processing CNC punching solutions (ALFA series); beams processing CNC drilling solutions (SIGMA); beams processing CNC punching solutions.

**Gerdau**  
booth 1441  
Tampa, Fla.  
ph: 800.367.8144 | toll free: 800.237.0230  
[www.gerdau.com](http://www.gerdau.com)

Gerdau Long Steel North America (GLN) manufactures merchant bar, structural steel, piling, special bar quality and rebar products for the agricultural, automotive, civil construction, distribution, energy, industrial, and mining markets. GLN operates six mills in the U.S. and three in Canada, and is a wholly owned subsidiary of Gerdau S.A.

**GH Cranes & Components**  
booth 2130  
Terrell, Texas  
ph: 972.563.8333  
[www.ghcranes.com](http://www.ghcranes.com)

GH Cranes & Components is a family-owned business established in 1958 manufacturing overhead material handling such as cranes, hoists, gantry cranes, RTGs and jib cranes. Since then, we have installed more than 125,000 equipment worldwide. Our manufacturing capabilities in Texas, as well as a full inventory of spare parts and well-trained service crew, assure your total satisfaction and performance.

**GIZA**  
booth 1133  
St. Louis  
ph: 314.656.4615  
[www.gizasteel.com](http://www.gizasteel.com)

GIZA is a connection design software that covers more than 400 different connection types in the shear, moment, vertical brace, horizontal brace and splice categories. Compliant to AISC 14th and 15th edition *Manual*—ASD and LRFD methods, GIZA provides a comprehensive set of calculations with references to all applied codes. We offer integration with Tekla Structures and Tekla Structural Designer but can also be used as a standalone option. GIZA has been in use for over 10 years and has successfully designed thousands of connections on thousands of projects over that time. Try it yourself free for 15 days!

**Gonza Joist**  
booth 1911  
Navolato, Sinaloa  
Mexico  
ph: 52.614.220.1562  
[www.gonzajoist.mx](http://www.gonzajoist.mx)  
Design and fabrication of joist and joist girders, certified by the SJI.

**Graitec**  
booth 1429  
[www.graitec.com](http://www.graitec.com)

**Grating Fasteners**  
booth 1822  
Harvey, La.  
ph: 504.361.3471 | toll free: 800.227.9013  
[www.gclips.com](http://www.gclips.com)

Grating Fasteners specializes in producing the G-Clip line of grating fasteners. G-Clips are used to attach grating to structural members using simple hand tools. The entire G-Clip line of fasteners are noted industry-wide as being a cost-effective, fast, and dependable way to fasten grating.

**Greenbrook Engineering Services**  
booth 1535  
Middlesex, N.J.  
ph: 732.412.8000  
[www.greenbrookengineering.com](http://www.greenbrookengineering.com)

FOCUS ON QUALITY, DELIVER ON TIME. Greenbrook Engineering is an MBE certified company specializing in connection design, structural steel, miscellaneous steel and rebar detailing, and BIM coordination services for the steel industry. With offices in Phoenix, Ariz. and New Jersey, and production centers in Bangalore and Chennai, India, we serve structural engineers, steel fabricators, and architects.

**GRM Custom Products**  
booth 1919  
Conroe, Texas  
ph: 936.441.5910  
[www.grmcp.com](http://www.grmcp.com)

For over 60 years, GRM Custom Products has worked with engineers, steel fabricators, and contractors to provide customized high-quality products. The exclusive fabricator of Fluorogold Slide Plates in North America, we manufacture to meet your project's exacting specifications and expedited timelines, providing you with high quality products and consistent deliveries. We have grown our custom material offerings across bearing and thermal break pads. Now offering you a full line of plastics and FRP composite options, please stop by and visit us, we look forward to talking with you.

**Gsource Technologies LLC**  
booth 2024  
Hollywood, Fla.  
ph: 786.747.0941 | toll free: 888.322.9925  
[www.gsourcedata.com](http://www.gsourcedata.com)

Gsource is a steel modeling, detailing, architectural, MEP design, and mechanical modeling company based in Florida, serving over 280 active clients in North America for over a decade now helping the AEC industry and more, to complete their projects in a more effective and collaborative way. Our expertise includes 2D detailing, 3D modeling, shop drawings, erection drawings, IFC models, and NC and DXF files. We specialize in detailing for structural steel such as beams, columns, trusses, and column sets. Additionally, we are experts in miscellaneous steel, including stairs, handrails, ladders, platform railings, gratings, bollards, gates, and more.



## exhibitor list

### GWY, LLC booth 1434

Greenfield, N.H.  
ph: 603.547.3800  
toll free: 888.838.6500  
[www.gwyinc.com](http://www.gwyinc.com)



Since 1975, GWY has been a global leader specializing in the sales, rental, repair, and calibration of installation tools for structural bolts. Our Turn-of-Nut wrench series are custom designed in partnership with the global leader in electric tool companies, Tone. Using our years of experience in bolt fastening with Tone's years of quality wrench manufacturing, we have created a wrench that meets the high standards of the federal government for structural fastening. Other product lines include the popular shear wrenches for TC bolts, torque wrenches, bolt tension calibrators, rebar tying tools, and hydraulic products.

### Harbor Fab booth 1151

Fort Worth, Texas  
ph: 682.350.3550  
[www.harborfab.com](http://www.harborfab.com)

Since 1972, we have served industrial and commercial markets with miscellaneous metal fabrications. Harbor Fab now offers pre-engineered stairs, rails, ladders, and platforms nationwide in addition to our custom designed products.

### Haydon Bolts, Inc. booth 1209

[www.haydonbolts.com](http://www.haydonbolts.com)

### HEICO Fastening Systems

booth 1463  
[www.heico-lock.us](http://www.heico-lock.us)

### Hercules Bolt Company

booth 1417  
Madison, Tenn.  
ph: 615.321.5020 | toll free: 877.321.5020  
[www.herculesbolt.com](http://www.herculesbolt.com)

Hercules Bolt & MFG, is a Veteran-Owned, certified "VOSB" company that is an industry leader in the manufacturing of structural anchor rods (bolts), sag rods, square plate washers, all-thread rod, and embeds; which are all proudly made with domestic material of all grades, alloys, and sizes (bent or straight). Our strong distribution stock of structural bolts makes Hercules Bolt a one source stop for any job that needs on time delivery with quality products. No job is too big or too small for Hercules Bolt & MFG.

### Hexagon

booth 1605  
Madison, Ala.  
ph: 281.890.4566  
[hexagon.com](http://hexagon.com)

Hexagon is a global leader in software, design, project performance, and autonomous solutions that boost efficiency, productivity, and quality across industrial, manufacturing, infrastructure, safety, and mobility applications. We empower our clients to transform unstructured information into a smart digital asset to visualize, build, and manage structures and facilities of all complexities, ensuring safe and efficient operation throughout the entire lifecycle.



**BULL MOOSE**  
TUBE

[BullMooseTube.com](http://BullMooseTube.com)  
800.325.4467

## SPENDING GREEN... TO GO GREEN

Bull Moose made a major investment in a new 350,000 ton-per-year facility in Sinton, Texas - with the goal of providing you with the "greenest" steel tube in North America.

- **PROMOTING SUSTAINABILITY**  
Our state-of-the-art facility boasts the lowest carbon footprint for steel pipe & tube in North America.
- **INVESTING IN HSS CAPACITY**  
Our new mill enables us to produce up to 14" square and 18" round, up to 3/4" walls, and the ability to enter the pipe pile market.



**HELPING YOU ACHIEVE YOUR GREEN INITIATIVES WITH:**  
A252 A500 A847 A1085 CSA G40.20/G40.21 EN 10219

Scan for more  
about our HSS



The answer for all your structural needs.



**PCR42 Robotic Beam  
Coping Machine**

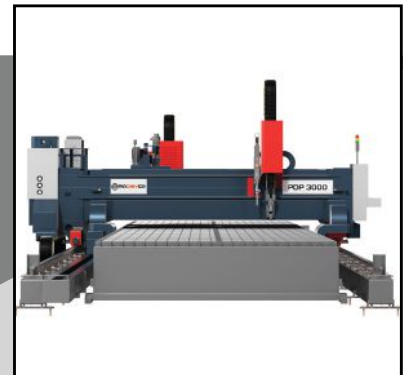

**PDP 3000 Plate Drilling  
& Plasma Cutting Machine**

**Come visit us at NASCC:**  
The Steel Conference **booth #832**  
on **March 20-22 in San Antonio, Texas**

<https://prodevcoind.com>  
[sales@prodevcorobotics.com](mailto:sales@prodevcorobotics.com)  
+1 (877) 226-4501

## exhibitor list :: NASCC: THE STEEL CONFERENCE

### Hilti Inc.

**booth 1511**

Plano, Texas

**ph:** 800.879.8000

[www.hilti.com](http://www.hilti.com)

Hilti is a world-leading manufacturer and supplier of quality, innovative and specialized tools and fastening systems for the professional user. With more than 1,350 highly trained Hilti account managers and engineers throughout North America and an additional 1,100 Hilti employees nationwide, Hilti expertise covers the areas of powder actuated fastening, drilling and demolition, diamond coring and cutting, measuring, firestopping, screw fastening, adhesive and mechanical anchoring, and strut and hanger systems.

### HI-Q Design Inc.

**booth 1817**

Mesa, Ariz.

**ph:** 347.615.6505

[www.hiqdesigninc.com](http://www.hiqdesigninc.com)

Established in 2004, HI-Q is a global structural steel and mechanical design and detailing service that has passionately executed projects across the globe. Every small, medium, and large project receives our undivided attention, making us the favored designed services company by many international customers. Our passion for excellence is matched by our team highly motivated, qualified, and experienced engineers and detailers who specialize in structural steel design and detailing, connection design, mechanical design, and piping design. With more than a decade of experience, we are well qualified to handle all your projects. Thank you.

### Holemaker Technology HMT

**booth 1659**

Clearwater, Fla.

**ph:** 833.642.2872 | **toll free:** 833.642.2872

[www.holemaker-technology.com](http://www.holemaker-technology.com)

Holemaker Technology is the specialist manufacturer of the patented VersaDrive metal drilling accessory system. Combining our pioneering, impact rated and now patented VersaDrive® system with the latest generation of high-torque cordless power tools has created a revolutionary level of drilling speed and performance, never before possible with portable tools. With a wide customer base across the U.S. in industries spanning construction, defense, manufacturing, MRO, transportation and infrastructure, and energy—HMT is sure to have timesaving solutions available for your application.

### Holloway Houston, Inc.

**booth 1558**

Houston

**ph:** 713.674.5631

[www.hhilifting.com](http://www.hhilifting.com)

Holloway is the foremost single-location sling shop and testing complex in the U.S. We boast a vast inventory of rigging products and a dedicated rental department tailored to your rigging needs. Here, you'll find a comprehensive array to meet your industrial lifting requirements, seamlessly merging premium products with state-of-the-art testing services, all accessible at our world-class testing facility.

### Holloway Steel Services

**booth 1910**

Saginaw, Texas

**ph:** 817.232.8663 | **toll free:** 800.869.8663

[www.hollowaysteelservices.com](http://www.hollowaysteelservices.com)

Holloway Steel Services specializes in structural steel rolling, plate rolling, ASME code vessels, shop fabricated tanks, and CNC plasma cutting. Holloway Steel Services is one of the premier steel fabricators serving customers in Texas, Colorado, Oklahoma, Arkansas, New Mexico, Louisiana, Arizona, and nationwide. Holloway Company Inc., is a family owned and operated enterprise that has been in business since 1971.

### HRV Conformance Verification Associates, Inc.

**booth 1745**

Moon Township, Pa.

**ph:** 412.299.2000

[www.hrvinc.com](http://www.hrvinc.com)

Leading experts in materials QA/QC inspection, coatings inspection, NDT, and CM/CI focused on transportation, rail and transit, oil and gas, power, commercial, water/wastewater, and aviation markets, with the capacity to provide AWS CWI, NACE, SSPC, ACI, PCI, and API inspections in materials fabrication plants and on project sites. We excel by maintaining high standards of technical training, leveraging deep industry knowledge and experience, practicing ethical conduct, applying innovative technologies, and communicating openly with our clients. We are Quality. Assured.

### HYTORC

**booth 1712**

Mahwah, N.J.

**ph:** 201.512.9500

[www.hytorc.com](http://www.hytorc.com)

HYTORC makes industrial bolting safer and simpler. With more than 50 years of experience focused entirely on developing the highest quality industrial bolting systems, HYTORC is the most trusted name in the industry. From steel mills and mining equipment to refineries, power plants, and wind turbines, we have developed solutions for every bolting application imaginable. For custom projects, our highly experienced engineering team is at your service to design the most efficient solution for your job with simple operation and economical pricing in mind.

### IAPMO Uniform Evaluation Service

**booth 1909**

Ontario, Calif.

**ph:** 909.472.4100 | **toll free:** 877.443.7778

[www.uniform-es.org](http://www.uniform-es.org)

IAPMO Uniform Evaluation Services (UES) provides summary reports specifically for the steel industry. These documents demonstrate product/material/system/design compliance to applicable codes and standards, expediting approvals within the building industry. Current steel-related activities include steel deck, steel wall, and roof cladding, structural steel members, cold-formed steel framing, steel connectors, steel fasteners, and fabrication. We offer true turnkey service from product testing by IBT, to Uniform Evaluation Reports, through ongoing manufacturing audits from quality control consultants.

### IDEA StatiCa US LLC

**booth 1405**

Mount Laurel, N.J.

**ph:** 856.642.4070

[www.ideastatica.com](http://www.ideastatica.com)

IDEA StatiCa Connection is a revolutionary software for structural design of steel connections/joints. It allows structural engineers to design and check connections of all configurations in minutes. IDEA StatiCa is improving workflow of engineers all around the world by linking to the analysis, BIM and detailing software they use.

### ideCAD

**booth 2032**

Bursa

Turkey

**ph:** 90.224.220.6717

[idecad.com](http://idecad.com)

ideYAPI has developed BIM software technologies in structural engineering, construction, and architecture since 1988. Operating with offices in Istanbul Bursa and Hannover (Germany), ideYAPI develops BIM technologies that quickly enable architects and structural engineers to implement their plans. The number of licensed users of ideYAPI is over 25,000. ideCAD is integrated AEC software for architecture, structural engineering, structural detailing, and construction from architectural design to fabrication.

### IES, Inc.

**booth 1619**

Bozeman, Mont.

**ph:** 406.586.8988 | **toll free:** 800.707.0816

[www.iesweb.com](http://www.iesweb.com)

For 30 years, Integrated Engineering Software (IES) has been developing user-friendly structural software that helps you efficiently solve a wide range of real-world problems. Our most versatile product, VisualAnalysis, can analyze and design almost any three-dimensional structure. In addition, we offer a variety of task-specific programs such as ShapeBuilder, VisualFoundation, ConcreteBending, ConcreteSection, VACconnect, and more. Discover why thousands of engineers worldwide depend on Integrated Engineering Software.

### IKG

**booth 1834**

Houston

**ph:** 281.452.0709 | **toll free:** 800.324.8417

[ikg.com](http://ikg.com)

With over 100 years of experience, IKG® continues to lead the bar grating industry with high-quality products, unmatched expertise, and innovative solutions. Our skilled network of sales personnel and engineering staff provide consultative services and solutions to customers in a wide range of industries. For quick delivery, IKG manufactures high-quality bar grating with several plants throughout the U.S. and Mexico. Through consistent, competitive, and dependable customer care, Forging Partnerships™ has become synonymous to IKG.

### Indiana Grating Pvt. Ltd.

**booth 1933**

[www.indianagroup.com](http://www.indianagroup.com)



**Indiana Steel Products, Inc.**  
booth 1946  
[www.indianasteelproducts.com](http://www.indianasteelproducts.com)

**Infasco**  
booth 1740  
Marieville, Quebec  
Canada  
ph: 450.658.8741 | toll free: 800.876.9473  
[www.infasco.com](http://www.infasco.com)

Infasco designs, manufactures, and distributes threaded fasteners and forged steel parts to various industries which, among others, includes construction and infrastructure, heavy trucks and equipment, as well as automotive and agriculture. Infasco puts its 60+ years of experience and expertise to work with its customers to develop tailor-made products that improve their current fastener products. With one manufacturing facilities in Marieville (QC), as well as seven distribution centers in U.S. and Canada, Infasco's 400 employees can service customers anywhere around the world. Ask for our new product 1¼ F2280 (Coated A490 TC).

**Informed Infrastructure**  
booth 2028

West Allis, Wis.  
ph: 312.771.9818  
[www.informedinfrastructure.com](http://www.informedinfrastructure.com)

Informed Infrastructure is the leading media outlet for civil and structural engineers. We reach 40,000 readers via our magazine, weekly eNewsletter, web site, video content, surveys and our industry leading continuing education platform.

**InfoSight Corporation**  
booth 1035

Chillicothe, Ohio  
ph: 740.642.3600 | toll free: 800.642.3600  
[www.infosight.com](http://www.infosight.com)

Infosight is a leader in identification technology specializing in creating innovative identification solutions for harsh environments, improving safety outcomes, and enabling traceability. Our equipment comes with dedicated 360° support and unparalleled durability. InfoSight offers tags specifically designed for fabricators and galvanizers that survive hot-dip galvanizing, shot blasting, painting, and powder coating, leaving your asset with a scannable barcode or readable serial number. Our tags can be customized with a variety of alphanumeric characters, graphics, logos and barcodes printed with our Labelase® Printers.



Color Key:

Bridge Pavilion Exhibitor  
Heavy Machinery Area  
Safety Pavilion Exhibitor

**Infra-Metals Co.**  
booth 1015

Newtown, Pa.  
ph: 215.741.1000 | toll free: 800.899.3432  
[www.infra-metals.com](http://www.infra-metals.com)

Infra-Metals Co. is one of the largest structural steel service centers in the U.S. We are well-positioned to satisfy your needs in New England, Mid-Atlantic, Midwest, South, and Southwest. As a subsidiary of a leading international company, Infra-Metals is provided with secure financing and has a strong commitment to steel distribution and processing. Infra-Metals offers unparalleled service with on-time delivery and a substantial lineup of processing equipment. Anyone can quote a price, Infra-Metals can quote it from stock.



**Innovatech**  
booth 115

Kanarrville, Utah  
ph: 435.704.7388  
[www.innova.tech](http://www.innova.tech)

Working hand-in-hand with BZI as an erection and fabrication partner has provided our team a unique and seamless feedback and testing environment. Our relationship allows Innovatech to continuously improve our products and look for new opportunities to make steelwork safer, simpler, and more efficient. Construction, Technology, Solutions

**International Design Services, Inc.**  
booth 1133

St. Louis  
ph: 314.872.1791  
[www.ids-inc.net](http://www.ids-inc.net)

IDS is committed to delivering the highest quality of detailing and connection design services. Our over 500 team members, including connection design engineers, detailers, and supporting staff provide ample manpower to support any project type and schedule. Our shop drawings and calculations are produced under the direct supervision of licensed professional engineers. In addition to 3D and BIM Models in SDS2 or Tekla, IDS provides NC1, CNC, DXF, DSTV, and other production file formats.

**International Zinc Association**  
booth 1765

Durham, N.C.  
ph: 919.287.1877  
[www.zinc.org](http://www.zinc.org)

IZA MISSION: Provide global leadership, coordination, and value on strategic issues for the zinc industry, including market development, license to operate, communications, and sustainability.

**Interstate Gratings**  
booth 1915

London, Utah  
ph: 801.922.4700 | toll free: 888.499.8494  
[www.interstategratings.com](http://www.interstategratings.com)

Interstate Gratings operates in a 120,000 sq. ft fully-integrated manufacturing and fabricating facility, ideally located in the hub of the west. We have a highly experienced in-house detailing and project management team. Our custom automated CAD solutions provide seamless integration with our shop processes and our advanced CRM solution accurately tracks jobs from start to finish. With an expert team of grating professionals, state-of-the-art equipment and integrated technology, Interstate Gratings is prepared to take on jobs of any scope or schedule.

**Ironworkers / IMPACT**  
booth 2047

Washington  
ph: 202.393.1147 | toll free: 800.545.4921  
[www.impact-net.org](http://www.impact-net.org)

IMPACT is a labor management partnership designed to provide a forum for union ironworkers and their signatory contractors to address mutual concerns and encourage reasonable, balanced solutions. Our primary mission is to expand job opportunities through progressive and innovative labor management cooperative programs, providing expertise in ironworker and contractor training, construction certifications, safety, marketing and construction project tracking and bidding.

**IRyS Global Inc.**  
booth 1905

Rodney, Ontario  
Canada  
ph: 519.652.6625  
toll free: 800.711.IRYS  
[www.irysglobal.com](http://www.irysglobal.com)



Your Desktop without Limits. Bring SDS2 detailers, management, engineers and fabricators together in one place with IRyS Global's remote desktop solution. IRyS utilizes premium hardware and is a fast, reliable solution capable of hosting your entire desktop on the cloud. Feel secure with 24 hour support, multiple points of data back-up and no contracts. Low monthly fee. No data limits. Cancel any time. Access your data effortlessly from anywhere in the world, at any time, on any device. Request a demo at [www.irysglobal.com](http://www.irysglobal.com)

**ISC**

booth 1908  
St. Louis  
ph: 314.434.2888 | toll free: 800.888.3326  
[efc-intl.com](http://efc-intl.com)

Inventory Sales Company is an industry leader for fasteners, weld studs, sign hardware, frames, strut, and steel fabrication. As a division of EFC International, we have strategic partnerships with world-class manufacturers to offer you engineered solutions in industrial applications.

## exhibitor list :: NASCC: THE STEEL CONFERENCE

### ISD Group USA

**booth 1929**

Cornelius, N.C.

**ph:** 704.519.2498

[www.isdgroup.us](http://www.isdgroup.us)

ISD Group is a provider of 2D/3D engineering and design software that offers innovative solutions for the structural engineering sector. With over 45 years of experience in the steel, metal and facade sector, the company is an expert for 2D/3D modeling software with automation to production output and integrated project/drawing management. Conceptualize your ideas at high speed with the extensive solution for engineering.

### J. B. Long, Inc.

**booth 1047**

Fleetwood, Pa.

**ph:** 610.944.8840

[www.jblong.com](http://www.jblong.com)

Cheap Detailing Ain't Cheap! Save money on detailing only to spend much more on fabrication and erection. J.B. Long, Inc. has supplied quality structural steel and miscellaneous iron detailing to the fabrication industry since 1985.

### JH Botts LLC

**booth 1209**

Joliet, Ill.

**ph:** 815.726.5885 | **toll free:** 800.888.5885

[www.jhbotts.com](http://www.jhbotts.com)

As specialists in manufacturing anchor bolts from raw material emphasizing ASTM F1554 and ASTM A449 material, we stock many ½–3½ in. diameter round bars in 20 ft-0 to 40 ft-0 lengths. Additionally, we can manufacture using many different grades of material including ASTM A615 rebar, stainless steel rods and other assorted carbon steel grades. Our ability to produce within the tolerances prescribed by the American National Standards Institute (ANSI) make us a valuable asset to our customers.

### JMT Consultants Inc.

**booth 1624**

Atlanta

**ph:** 204.510.1547

[www.jmtconsultants.com](http://www.jmtconsultants.com)

JMT Consultants was founded in 2008 to provide quality and reliable steel and concrete detailing and design services to the construction industry. Working directly for developers, engineering firms, general contractors and fabricators, we are a full-service company, operating with integrity, loyalty, and treating each customer how we would want to be treated. These principles have led JMT Consultants to become an award-winning industry leader. We believe in a collaborative, organized and efficient process to complete projects on schedule and on budget.

#### Color Key:

Bridge Pavilion Exhibitor

Heavy Machinery Area

Safety Pavilion Exhibitor

### JPW Engineering Services

**booth 2119**

League City, Texas

**ph:** 713.589.4577

[www.jpwespl.com](http://www.jpwespl.com)

JPW specializes in structural and misc. steel detailing. Along with detailing, JPW provides model-based estimation, connection design, and stamping for the U.S. and Canada. We follow the triangular approach to build a sustainable and long-term partnership with the clients. This includes effective communication, quality work, and scheduled deliverables. The core strength of JPW's success is its checking process. The two layers method has helped to achieve mostly error-free drawings. When it comes to quality, JPW appears at the top of the list.

### Kinetic Cutting Systems, Inc.

**booth 432**

West Burlington, Iowa

**ph:** 319.754.5040 | **toll free:** 800.606.2954

[www.kineticusa.com](http://www.kineticusa.com)

Kinetic manufacturers a variety of precision CNC plasma and flame cutting machinery, as well as multi-process machines that combine machining operations such as drilling, tapping, milling and interpolation with cutting operations. One Machine—Complete Parts—Start to Finish. Kinetic offers a complete solution for the structural steel industry.

### Kjellberg Cutting, Inc.

**booth 550**

Lewisville, Texas

**ph:** 469.770.9799

[www.kjellbergcutting.com](http://www.kjellbergcutting.com)

Manufacturer of high precision plasma cutting systems for use in automated production cutting of steel, stainless steel, aluminum and other materials. Kjellberg is a leader in cut quality and cost per cutting foot.

### Kloekner Metals

**booth 1564**

Roswell, Ga.

**ph:** 678.259.8800

[www.kloeknermetals.com](http://www.kloeknermetals.com)

Founded in 1906, Kloekner Metals Corporation is one of the largest metals manufacturing, supply, and service companies in North America. With over 40 branches in the U.S. and over 200 worldwide, Kloekner is committed to providing customers with the latest fabrication and processing technologies and the most innovative customer service solutions. Boasting one of the most extensive product portfolios in North America, our promise is unparalleled quality of both product and service.

### Kobelco Welding of America, Inc.

**booth 100**

Stafford, Texas

**ph:** 281.240.5600

[www.kobelcowelding.com](http://www.kobelcowelding.com)

Kobelco, your best partner for structural steel fabrication, including seismic application is proud to be one of the few companies that develops all of its own original welding materials, welding robots, and welding power sources.

### Kottler Metal Products, Inc.

**booth 1529**

Willoughby, Ohio

**ph:** 440.946.7473 | **toll free:** 800.678.0808

[www.kottlermetal.com](http://www.kottlermetal.com)

Structural steel bending and fabricating specialist Kottler Metal Products is proud to have one of the largest pipe, tube, and structural steel bending capacities in the Midwest, bending up to 10 in. angle, 20 in. pipe and tube, and 40 in. channel and I-beam, both easy-way and hard-way. Family owned and built on a 100+ year legacy, our business philosophy is based on a dual commitment to quality and service. For five generations, we have maintained the tradition of producing the highest caliber of metal fabrications throughout the world.

### KTA-Tator

**booth 1733**

Pittsburgh

**toll free:** 800.245.6379

[kta.com](http://www.kta.com)

KTA provides government, facility owners, engineers and contractors peace of mind that the integrity of steel and concrete structures are properly assessed and protected. KTA provides professional consultation and support during any phase of a project—design, construction, post-construction, and maintenance. KTA's specialties include steel and concrete fabrication inspection; NDT; coatings and corrosion engineering and inspection; field and lab coatings failure analysis; and coatings training. KTA also distributes a complete line of field inspection instrumentation.

### Lampson International

**booth 1753**

Kennewick, Wash.

**ph:** 509.586.0411

[www.lampsoncrane.com](http://www.lampsoncrane.com)

Lampson International, LLC has one of the largest crane rental fleets, with over 400 pieces of equipment. Our cranes range from 300 U.S. ton to 3,000 U.S. ton, including conventional Crawler Cranes, the Lampson Millennium 4100 and 4600 Crawler Cranes, and our Lampson proprietary product, the Lampson Transi-Lift. With offices located throughout the U.S., Canada, and Australia we are well positioned to meet our customers needs anytime and anywhere.

### LAP Laser LLC

**booth 1510**

[www.lap-laser.com](http://www.lap-laser.com)

### LARSA, Inc.

**booth 1723**

Melville, N.Y.

**ph:** 212.736.4326 | **toll free:** 800.LARSA.01

[www.larsa4d.com](http://www.larsa4d.com)

LARSA develops advanced 3D finite-element analysis software for bridges. Engineers rely on LARSA as the only software capable of advanced modeling techniques with the essential tools needed to handle complex geometries and elaborate staging. Backed by the industry's most responsive support team, engineers rapidly receive personalized assistance informed by our decades of experience advancing structural analysis software. Visit us to learn why LARSA's Steel Bridge Module leads the way for the design and rating of steel girder bridges at the nation's leading firms and state DOTs.



**LeJeune Bolt Company**  
booth 1005

Burnsville, Minn.  
ph: 952.890.7700 | toll free: 800.872.2658  
[www.lejeunebolt.com](http://www.lejeunebolt.com)

LeJeune Bolt is the leading international supplier of structural fasteners and tools as well as your source for the ASTM F3148 TNA Fastening System. With the approval of F3148 and the combined method by RCSC and upcoming publication by AISC and AREMA F3148 TNA, bolt assemblies and torque and angle installation can be specified with confidence. Contact LeJeune Bolt Company to learn more about how our TNA Fastening System can provide improved efficiency, quality control, and cost savings for your next project.

**Lichtgitter USA**  
booth 1759  
[www.lichtgitterusa.com](http://www.lichtgitterusa.com)

**Lincoln Electric**  
booth 712

Cleveland  
ph: 216.481.8100  
[www.lincolnelectric.com](http://www.lincolnelectric.com)

Lincoln Electric is the world leader in arc welding, robotic welding systems, plasma and oxyfuel cutting equipment and brazing and soldering alloys. Headquartered in Cleveland, Lincoln has a worldwide network of manufacturing, distribution, sales and technical support covering more than 160 countries.

**Lindapter**  
booth 1635

Leander, Texas  
ph: 866.566.2658  
[www.Lindapter.com](http://www.Lindapter.com)  
Over 90 years, Lindapter has pioneered the design and manufacture of structural steel clamping systems and HSS blind fasteners, enabling faster steel construction. Products include the Hollo-Bolt, the HSS expansion bolt approved by ICC-ES for all seismic design categories (A through F); while the girder clamp is approved for quickly connecting W and S beams. Lindapter connections eliminate the need for time-consuming drilling or welding in the field and reduce time and labor costs.

**LNA Solutions**  
booth 1343  
[www.lnasolutions.com](http://www.lnasolutions.com)

**LS Industries**  
booth 1247  
Wichita, Kan.  
ph: 316.265.7997 x323  
toll free: 800.835.0218 x323  
[www.lsindustries.com](http://www.lsindustries.com)

LS Industries engineers, designs and manufactures surface preparation equipment, including shot blasters, washers and vibratory tubs. Our ability to engineer and manufacture custom solutions allows us to provide the full line of finishing equipment. We are a fully integrated manufacturer of airless shot blast cabinets using conveyor and monorail systems. LS Industries has solutions for cleaning rebar, pipe and tubing and structural steel. Solutions can range from fully automated to manual, economical solutions all designed to improve quality and reduce labor.

**For the fabricator looking to maximize** their production time and profits, the Lightning Rail is a smart decision.

Eliminate the countless manual labor hours involved in laying out handrails, stair stringers, trusses, and more!

- ✓ Cut fabrication time by more than 50%
- ✓ Ensure the highest level of accuracy
- ✓ Boost your profit margins
- ✓ Lay out complex geometry in seconds
- ✓ Designed to replace your existing fabrication table



"The guys love it. They jumped right in on it and have been working to make the most use of it. Great purchase."

**Nat Killpatrick**  
Basden Steel Corporation

"I think it's fair to say that this machine continues to exceed our expectations. We are very happy with it."

**Chief Operating Officer**  
Koenig Iron Works



by Automated Layout Technology™

  
Patent No. US 10,576,588 B2  
Patent No. US 11,426,826 B2

**SPEED, ACCURACY, & HIGHER PROFIT MARGINS**

**603-402-3055**  
[AutomatedLayout.com](http://AutomatedLayout.com)



## exhibitor list :: **NASCC: THE STEEL CONFERENCE**

### LTC Software Solutions

**booth 1041**

Onalaska, Wis.

**ph:** 608.786.0893

**www.ltcsoftwaresolutions.com**

LTC Software Solutions is both a custom software developer and a registered Tekla Software Development Expert. We help companies with custom reporting, productivity tools, app integrations, custom app builds, dashboards, portals, and business intelligence. Specific to the steel construction industry, we are experts in Tekla PowerFab/EPM and Tekla Structures. From simple custom reporting out of PowerFab, to integrations with pricing/estimate tools, to complex custom components tapping the API, LTC Software Solutions can improve your firm's productivity and profitability.

### LTC Virtual Design and Construction

**booth 1041**

Onalaska, Wis.

**ph:** 608.786.0893

**www.LTCvdc.com**

LTC is a leading virtual design and construction (VDC) firm, providing world class preconstruction through project turnover services to architects, engineers, contractors, and fabrication shops across North America. From its founding as a steel detailing company, to its evolution as a BIM solutions provider, to its most recent expansion into VDC, LTC has always put clients first. With continuous investment into software customization and development, LTC's clients receive service and products that are specific to their individual needs, and efficiently produced in a timely manner.

### LUSAS

**booth 1758**

Kingston upon Thames, Surrey

United Kingdom

**ph:** 646.837.8756 | **toll free:** 800.97.LUSAS

**www.lusas.com**

LUSAS finite element analysis software provides accurate and cost-effective analysis, design and load rating of steel and concrete bridges. Used widely by consultants and DOTs for frequency, seismic, dynamic, nonlinear, buckling, fatigue, staged construction, creep and shrinkage, prestress/post-tensioning, soil-structure and rail track-structure interaction modeling and many other forms of analysis. Vehicle-load optimization facilities provides worst-case traffic and rail loading patterns. AASHTO and other design codes supported. Extensive results viewing and reporting options.

### Mac-Tech

**booth 853**

Milwaukee

**ph:** 414.486.9700

**www.mac-tech.com**

Our philosophy has remained consistent over the last 40 years: We maintain a relentless obsession to serve our customers. Mac-Tech was founded in 1984 to service and support metal fabrication equipment. We've been in business for over 40 years and are well-positioned to service and support our customer base throughout North America. At Mac-Tech, we strive to develop long-term partnerships with our customers and leave a positive lasting impression every time.

### Magni Telescopic Handlers

**booth 1833**

Roselle, N.J.

**ph:** 908.280.8899 x110 | **toll free:**

833.624.6487

**www.MagniTH.com**

Magni Telescopic Handlers is the world leader in rotating, fixed boom and heavy lift telehandlers. Eliminate the need to rent a crane! Magni offers 16 rotating models with lift heights from 57-167 ft and lifting capacities from 8,800-28,600 lbs. There are 100 attachments which allow the machine to serve as a telescopic forklift, RT crane, aerial work platform, and more. Magni's are the safest, most productive and efficient machines in their class. Check out our new line of fixed boom 10K and 12K machines with safety no one has. We offer eight heavy lift models with lifting capacities from 22,000 to 110,000 lb.

### Magnum Consulting

**booth 1465**

Novi, Mich.

**ph:** 248.773.8055

**www.4Magnum.com**

We provide a wide array of engineering and design services including mechanical conveyor engineering, structural engineering and detailing, production tooling design, project management, and conveyor/structural health assessments. We create designs for pallet systems, chain on edge, OHPE, IPF, monorail, pendulum, lifts, carriers, AGV/AGC, and other equipment/conveyor systems. Our structural engineering team designs large, complex structures using the latest engineering software and technology. Magnum has extensive knowledge in accommodating structures for machines, conveyors, robots, and other heavy industrial equipment.

### MARKO Metal Systems

**booth 1942**

Memphis, Tenn.

**ph:** 901.648.8866

**www.markosys.com**

With over 45 years of know-how in the segment, Marko has established itself as an industry providing solutions in metal systems for the construction market, which perform more than just the functions satisfactorily. They offer the end user, architects, construction companies, and distributor network, fast, economical, and efficient processes. Exclusive manufacturer of the Roll-on metal roofing system and MARKO Joists, the Joist in Time system, the company has the ideal solution for small, medium, or large buildings.

### Maruichi Leavitt Pipe and Tube

**booth 1620**

Chicago

**ph:** 773.239.7700 | **toll free:** 800.532.8488

**www.maruichi-leavitt.com**

Maruichi Leavitt Pipe and Tube is an industry leader, operating four tube mills, with one of the broadest size ranges of structural (ASTM A500) tube, mechanical (ASTM A513) tube, standard pipe (ASTM A53) and automotive (JIS G3445) in the industry. Based in Chicago.

### Max Weiss Co., LLC

**booth 1243**

Milwaukee

**Ph:** 41.208.5089 | **toll free:** 888.649.3477

**www.maxweiss.com**

Our unique structural rolling/forming process and skilled craftsmen provide exceptional quality and tight radius bending with very minimal distortion or marring. We have the capability of rolling and forming a wide variety of sizes of structural steel sections and tubing easy way, hard way, and off-axis to accommodate the most difficult and unique projects. We also offer many value-added fabrication services including splitting, notching, straightening, trimming, drilling, certified welding and much more.

### Mayvue Solutions

**booth 1760**

**www.mayvue.com**

### McLaren Engineering Group

**booth 1459**

Woodcliff Lake, N.J.

**ph:** 201.775.6000 | **toll free:** 800.420.6401

**www.mgmclaren.com**

McLaren is a multi-disciplinary engineering firm that specializes in steel building and bridge construction engineering design services. These include primary structural systems, complex connection design, miscellaneous metals, shoring/jacking, tower cranes, bid consultation, crane layouts, and erection stability. McLaren is licensed in 49 states, several U.S. territories and offers 10 offices nationwide with 250+ gifted design professionals. Our solutions blend cutting-edge innovation with a practical approach that is responsive to your needs.

### Messer Cutting Systems

**booth 215**

Menomonee Falls, Wis.

**ph:** 262.255.5520

**us.messer-cutting.com**

Messer Cutting Systems is a global supplier of cutting solutions for the metal-working industry. With our reliable cutting innovations and technologies, superior service, and intelligent software solutions, we are setting standards of solutions, services, and support worldwide. As the leader in the thermal cutting industry, we are working on smarter, faster, and more reliable solutions as an added value for our customers. This is what motivates our nearly 1,000 experienced employees in five main locations every day. Messer Cutting Systems is actively supporting our customers in more than 50 countries.

### Metal Supermarkets

**booth 1747**

Etobicoke, Ontario

Canada

**ph:** 905.362.8226

**www.metalsupermarkets.com**

The world's premier metal supplier! Instant access to over 8,000 types, shapes and grades of metal. We make finding, buying and receiving the metals you need easy!



**Metals USA**

**booth 817**

Langhorne, Pa.

**ph:** 267.580.2100 | **toll free:** 800.523.3340

[www.metalsusa.com](http://www.metalsusa.com)

Structural fabricators across North America trust and rely on Metals USA for their structural steel requirements. Metals USA is the industry-leading source for extensive inventory, and sophisticated processing services including plate burning/drilling, tee splitting, cambering, and press brake forming. Learn more about our wide range of product offerings to find out how we can help you achieve greater bottomline results. Steel, processing, service, and commitment. Metals USA—Your partner for all your steel needs.



**MetFin Shotblast Systems**

**booth 112**

Suffield, Conn.

**ph:** 860.668.1050 | **toll free:** 800.537.8966

[www.metfin.com](http://www.metfin.com)

MetFin Shotblast Systems is a 40-year-old American manufacturer of industry-leading, heavy-duty, automated shotblast equipment. Built on a lead team having hundreds of years of combined experience, we meet the unique production requirements of each customer by providing flexible and innovative solutions. MetFin tailors systems to integrate seamlessly into new or existing operations and provide years of dependable service in this demanding industrial environment. We take pride in building durable, easy-to-maintain blast equipment with a focus on our customers' long-term satisfaction.

**Meyer Borgman Johnson**

**booth 1141**

Minneapolis (headquarters)

**ph:** 612.338.0713

[www.mbjeng.com](http://www.mbjeng.com)

Meyer Borgman Johnson (MBJ) provides PE-licensed steel connection design, connected model delivery, erection engineering, stair and rail engineering, and related services to the structural steel community. We have one of the largest connection teams servicing the U.S. and Canadian markets. Providing consistent quality services, economic solutions and timely results are our top priorities. These services are a subset of our broad structural engineering services for the built environment. We have 80+ structural engineers and are licensed throughout the U.S. and Canada.

**Mid Atlantic Global**

**booth 542**

Harrisburg, Pa.

**ph:** 717.541.1633

[www.midatlanticglobal.com](http://www.midatlanticglobal.com)

At Mid Atlantic Global, we live and breathe fabrication technology. That's just one of the reasons businesses who process metal to make parts and products turn to us when they need new equipment. Our team has decades of experience working with small job shops and international manufacturers alike, and can specify, design, procure and install the perfect machine for just about any application.

**Miller Electric Mfg. LLC**

**booth 1351**

Appleton, Wis.

**ph:** 920.734.9821 | **toll free:** 800.426.4553

[www.millerwelds.com](http://www.millerwelds.com)

Miller® is about building things that matter. We lead the welding industry in building advanced, solution-focused products and meeting crucial needs for welding safety and health. We're about the partnership and the work. Our products are designed with our users for manufacturing, fabrication, construction, aviation, motorsports, education, agriculture and marine applications. Miller Electric Mfg. LLC, is headquartered in Appleton, Wisconsin, and wholly owned by Illinois Tool Works (NYSE: ITW). The company maintains its industry leadership by setting the standard for reliability, quality and responsiveness. Our tagline, "The Power of Blue®"

**Miner Grating Systems, a Powerbrace Company**

**booth 1809**

Dallas

**ph:** 214.630.0033

[www.minergrating.com](http://www.minergrating.com)

Miner Grating Systems is North America's leading manufacturer and fabricator of grating products. Our lines consist of bar grating (Premier Grate), diamond safety grating (Premier Diamond), and round hole safety grating (Premier Grip). Our mission is to provide the highest quality grating products and be the most cost effective solution provider. We welcome the opportunity to partner on any projects requiring grating for steps, platforms, or walkways for use on OEM equipment or in plant maintenance.

**Mold-Tek Technologies Inc.**

**booth 1449**

Cumming, Ga.

**ph:** 330.294.4746

[www.moldtekeengineering.com](http://www.moldtekeengineering.com)

Mold-Tek Technologies, Inc. is a part of a 100 million group and stands as one of the foremost engineering and technology solutions partners for major players in the market. Our core expertise lies in delivering structural steel detailing and engineering services, as well as connection design certification and sealing with BIM coordination for steel fabricators across the U.S. and Canada. Adhering to ISO9001:2015 certification quality processes, We have consistently fostered enduring partnerships with our clients since our establishment. Our commitment is reflected in substantial internal investments in software development, QC, and training.



**NASCC Exhibit Sales**

**booth 1801**

Traverse City, Mich.

**ph:** 231.995.0637

[aisc.org/nascc/exhibit](http://aisc.org/nascc/exhibit)

NASCC: The Steel Conference is an affordable and easy way to reach your target customer. As an exhibitor, you can count on The Steel Conference to deliver more than 6,000 industry professionals; more than any other industry event of its kind. The Steel Conference exhibit hall is your chance to personally interact with key decision-makers in the structural steel industry. When it comes to steel design and construction, these key industry players come to find out what's new, who's got it, and how it can work for them. Don't be left out. Join other top suppliers and manufacturers today!

**National Association of Women in Construction**

**booth 2125**

Fort Worth, Texas

**ph:** 817.877.5551 | **toll free:** 800.552.3506

[www.nawic.org](http://www.nawic.org)

The National Association of Women in Construction (NAWIC) originated as Women in Construction of Fort Worth, Texas. Sixteen women working in the construction industry founded it in 1953. Knowing that women represented only a small fraction of the construction industry, the founders organized NAWIC to create a support network for women working in a male-dominated field. Women in Construction of Fort Worth was so successful that it gained its national charter in 1955 and officially became the National Association of Women in Construction. Today, NAWIC is still based in Fort Worth and has more than 115 chapters throughout the U.S.

**National Institute of Steel Detailing, Inc.**

**booth 2063**

Shelton, Wash.

**ph:** 925.294.9626

[www.nisd.org](http://www.nisd.org)

The National Institute of Steel Detailing (NISD) is an international association that advocates, promotes and serves the interests of the steel detailing industry. We are comprised of company owners and professionals in the steel industry and offer membership to steel detailing firms and associated companies and individuals. By fostering a professional approach to business and advocating improved quality through member networking, education and certification, our members are highly regarded by fabricators, architects, engineers, and contractors.

Color Key:

Bridge Pavilion Exhibitor

Heavy Machinery Area

Safety Pavilion Exhibitor

# exhibitor list :: **NASCC: THE STEEL CONFERENCE**

## National Steel Bridge Alliance

**booth 1863**  
Chicago  
**ph:** 312.670.2400  
[aisc.org/nsba](http://aisc.org/nsba)



The National Steel Bridge Alliance (NSBA), a division of AISC, is a national, non-profit organization dedicated to the advancement of steel bridge design and construction. NSBA functions as the voice of the bridge fabricators and steel mills while also partnering with the bridge design and construction community. NSBA's partners include AASHTO, FHWA, state DOTs, design consultants, contractors, and academia. With these resources, NSBA is uniquely positioned to find solutions to the toughest bridge challenges, including those related to cost, sustainability, and performance.

## New Millennium

**booth 1117**  
Fort Wayne, Ind.  
**ph:** 260.321.8080  
[www.newmill.com](http://www.newmill.com)

Control project costs, enhance project performance and ensure project success with New Millennium. From steel joists and joist girders to steel roof and floor deck, we engineer and manufacture cost-efficient, high-performance building solutions for a range of commercial applications. Our specialists assist you in specifying and engineering the steel joists and steel deck best suited for your project, whether it's in the education, multi-family, multi-story office, warehouse, or large-venue market. With manufacturing facilities across North America, we're built for collaborative, expedited project delivery.



**NEW MILLENNIUM**  
A Steel Dynamics Company

## Nexus Steel Detailing, Inc.

**booth 1750**  
Naperville, Ill.  
**ph:** 779.703.5626  
[www.nexus-es.com](http://www.nexus-es.com)



Nexus, with a highly experienced staff, provides connection design and steel detailing services for industrial and commercial steel structural projects. Detailing services include 3D modeling using Trimble Tekla software, generation of erection drawings, detail drawings, gather sheets, NC, DXF, KSS, EJE, SDNF IFC files and customized reports per customer requirements. Connection design services include design of connections per AISC standards in ASD or LRFD. We have the capability to design all connection types and the expertise to produce unique and complex designs in Excel or Mathcad. We maintain PE licensure in several states in the U.S.

## Nitto Kohki U.S.A., Inc.

**booth 1741**  
Roselle, Ill.  
**ph:** 630.924.9393 | **toll free:** 800.323.8828  
[www.nittokohki.com](http://www.nittokohki.com)

We manufacture the automatic feed magnetic base drills that self-regulate feed speed for optimum cutting with a number of safety features. These machines with JetBroach carbide-tipped cutters can significantly increase production while reducing labor hours and hazardous work. We also manufacture many other metalworking tools including portable hydraulic punches, bevellers, pneumatic and electric power tools.

## Nucor – Beam Mill Group

**booths 701, 801, 901**  
Charlotte, N.C.  
**ph:** 704.366.7000  
[www.nucoryamato.com](http://www.nucoryamato.com)

Nucor has two beam mills: Nucor-Yamato Steel Company in Blytheville, Ark., and Nucor Steel Berkeley in Huger, S.C. The Nucor-Yamato facility is the only North American producer of Aeos™ ASTM A913 high-strength structural steel beams. Beam Mill Group manufactures wide flange structural steel shapes (up through W14730 columns and W44 beams), H-piles (including HP16 and HP18), sheet piling, angles, channels and car building shapes. Grades include ASTM A36, ASTM A572, ASTM A588, ASTM A690, ASTM A709, ASTM A992, ASTM 913; and CSA G40.21-13 Grades 345WM and 345WMT.



## Nucor – Corporation

**booths 701, 801, 901**  
Charlotte, N.C.  
**ph:** 704.366.7000  
[www.nucor.com](http://www.nucor.com)

Nucor is North America's largest and most sustainable producer of steel and steel products. Nucor is proud to also be North America's largest recycler and uses recycled scrap to make high-quality steel with low carbon emissions using one of the cleanest and most energy efficient steelmaking processes available, electric arc furnace technology. Nucor and its affiliates manufacturer an unmatched array of steel and steel products including: carbon and alloy steel—in bars, beams, sheet and plate; hollow structural section tubing; electrical conduit; steel piling; steel joists and joist girders; steel deck; fabricated concrete reinforcing steel; cold finished steel; precision castings; steel fasteners; metal building systems; steel grating; wire; and wire mesh.



## Nucor – Fastener Division

**booths 701, 801, 901**  
Charlotte, N.C.  
**ph:** 704.366.7000  
[www.nucor-fastener.com](http://www.nucor-fastener.com)

Nucor Fastener manufactures high-quality hex head cap screws, finished hex nuts, structural bolts, nuts, assemblies, flange bolts and built-to-print fasteners, head styles and dimensions. Grades can be customized to meet individual specifications.



## Nucor – Plate Mill Group

**booths 701, 801, 901**  
Charlotte, N.C.  
**ph:** 704.366.7000  
[nucor.com/products/steel/plate](http://nucor.com/products/steel/plate)

Nucor Plate Mill Group manufactures a wide range of carbon, alloy, high-strength low alloy (HSLA), pressure vessel and heat treated (normalized and quenched and tempered) products available as discrete, cut-to-length, or coiled plate. Our mills offer a wide range of gauges, widths, lengths, and grades that are customized to meet each individual customer's precise specifications.



## Nucor Skyline

**booths 701, 801, 901**  
Charlotte, N.C.  
**ph:** 704.366.7000  
[www.nucorskyline.com](http://www.nucorskyline.com)

Nucor Skyline is the one source for all your piling needs, supplying and manufacturing an unparalleled assortment of bearing piles, sheet piles, spiralweld, rolled and welded, and ERW pipe, anchors, micropiles, threaded bars, tie rods, wide flange, other structural sections and accessories. Skyline Steel, LLC (doing business as Nucor Skyline) is a wholly owned subsidiary of Nucor Corporation, North America's most diversified steel and steel products company. Nucor Skyline serves the U.S., Canada, Mexico, the Caribbean, Central America, and Colombia markets.



## Nucor Tubular Products

**booths 701, 801, 901**  
Charlotte, N.C.  
**ph:** 708.496.0380 | **toll free:** 800.376.6000  
[www.nucortubular.com](http://www.nucortubular.com)

Nucor Tubular Products is committed to unmatched quality and service. With eight locations located across the U.S. and a vast array of sizes and products produced, we can meet any specifications your project requires. NTP manufactures high-quality HSS, piling, A53 pipe, fire protection sprinkler pipe, auto mechanical tubing, and electrical steel conduit meeting ASTM A500, A1085, A53, A513, A252 and A153/A175 specifications, among others. Our products are made from Nucor sheet steel from an electric arc furnace (EAF), making them the most sustainable tubular products available.



Color Key:

Bridge Pavilion Exhibitor  
Heavy Machinery Area  
Safety Pavilion Exhibitor



## exhibitor list

### Nucor Vulcraft/Verco Group booths 701, 801, 901

Charlotte, N.C.  
ph: 402.844.2400  
[www.vulcraft.com](http://www.vulcraft.com)

The Nucor Vulcraft/Verco group engineers and manufactures steel joist, deck for structural roof and floor systems along with steel bar grating. We also offer multiple design tools and resources to support the design community across the U.S. and Canada.



### NuWave Laser Cleaning booth 1064

St. Hedwig, Texas  
ph: 830.433.1160  
[www.nuwavelaser.com](http://www.nuwavelaser.com)

Laser cleaning is a non-contact method of removing surface contaminants, such as rust, dirt, dust, and oxidation, from a variety of materials. It uses a focused beam of light energy to vaporize and remove the contaminants without causing damage to the underlying substrate. Laser cleaning does not produce any chemical waste, making it an environmentally friendly option. One of the main benefits of laser cleaning is that it is highly precise and can target specific areas without affecting surrounding areas. Additionally, it is a fast and efficient process that can save time and labor costs compared to traditional cleaning methods.

### Oates Metal Deck & Building Products, Inc. booth 2019

Pasadena, Texas  
ph: 713.475.0427  
[oatesmetaldeck.com](http://oatesmetaldeck.com)

Oates Metal Deck is a stocking distributor of SDI manufactured steel roof deck and composite/non-composite floor deck. We offer expedited lead times for supplying jobs all over the country, as we have most profiles in stock in various gauges and lengths and can cut to size, organize logistics, and have projects detailed to avoid unnecessary waste. We also stock and distribute accessories such as fasteners, weld washers, cell closure, pour stop, and girder filler.

### Ocean Machinery, Inc. booth 512

Fort Lauderdale, Fla.  
ph: 954.956.3131  
toll free: 800.286.3624  
[www.oceanmachinery.com](http://www.oceanmachinery.com)



Ocean Machinery delivers versatile and affordable solutions for the small to medium fabricator. Including: Ocean Avenger and Avenger Plus—the world's best-selling CNC beam drill lines; Ocean Clipper II—the most compact CNC angle line; Ocean Liberator—the most affordable CNC beam coping machine; Ocean Blaster—the smallest footprint shot blasting solution; and Ocean Challenger—a compact, automated welding robot. Plus, several other game changing solutions that improve the efficiency and profitability of fabricators worldwide!

## See that the bolts are tight! Squirter® DTIs

the best way to bolt!™



Booth 1329  
NASCC  
THE STEEL CONFERENCE  
SPONSOR  
2024



1.800.552.1999

[appliedbolting.com](http://appliedbolting.com)

Designed, Engineered & Made In USA Since 1994



Meet our **EXPERTS**, learn about our **FASTENING SOLUTIONS** and how we can help you with your **NEXT APPLICATION.**

## NASCC The Steel Conference

MARCH 20-22, 2024

San Antonio

## STOP BY OUR BOOTH 1617

With the participation of



A SISTER COMPANY OF  
**FONTANA GRUPPO**  
FASTENING THE FUTURE

[www.fontanagruppoagtna.com](http://www.fontanagruppoagtna.com)

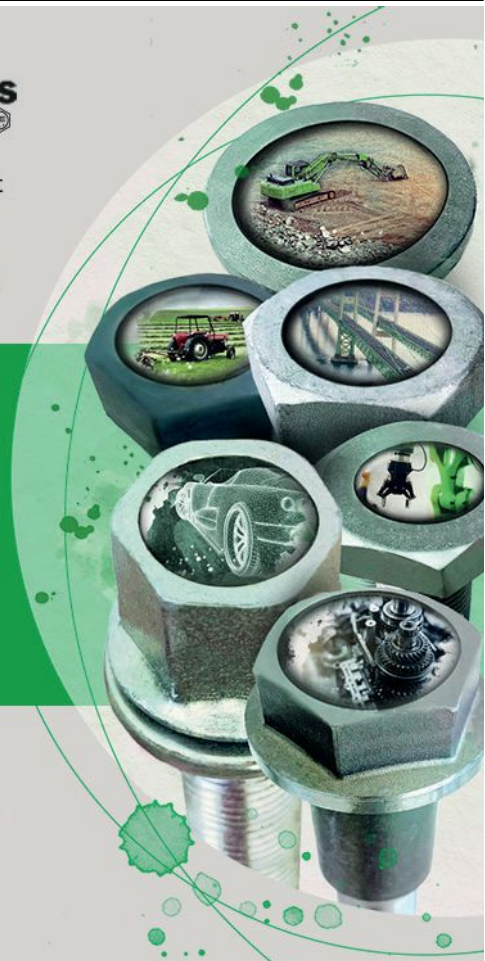

## Ohio Gratings, Inc.

**booth 1766**

Canton, Ohio

**ph:** 330.477.6707 | **toll free:** 800.321.9800

**www.ohiogratings.com**

Ohio Gratings is a leading manufacturer of aluminum, carbon, and stainless steel bar grating products—all proudly made in the U.S. We deliver a blend of artistry, safety, and innovation that's unmatched. From design and manufacturing to custom fabrication, our grating experts partner with you to find the complete solution to meet your needs. Our Traction Safety Products—ALGRIP® and OnGrip® provide increased traction on grating and metal flooring applications meeting ADA and OSHA requirements. It's this search for the unexpected that helps us repeatedly surprise and satisfy customers, keeping them "A Step Ahead."

## OpenBrim Platform

**booth 1912**

New York

**ph:** 212.991.8956

**openbrim.org**

Taking complexity out of digital/brim delivery! OpenBrim is the world's first and only on-cloud, collaborative parametric information modeling platform that combines 3D modeling, FEA, CAD, code check, load rating, inspection, asset management, and more in your web browser. Not only do we provide high ROI on resources by automation, reusability, and interoperability, but we also provide flexibility by customized workflows and dedicated engineering support. Having industry-leading customers and the OpenBrim community, we are the pioneers of digital transformation and innovation. Try for free in your web browser!

## OTH – Remote Controlled Hooks

**booth 1828**

**othrigging.com**

## OVA

**booth 1852**

**www.ova.ai**

## Ovation Services LLC

**booth 1253**

Copley, Ohio

**ph:** 330.730.7433

**www.4ovation.com**

Ovation Services is a leading provider of engineering services. Combining experience, technology and a client-centric approach, Ovation Services provides structural steel detailing, connection design and BIM services across the U.S. The Acquisition of MMW, Inc. a detailing firm with over 30 years of experience in the steel industry, gives Ovation Services a talented project management team to ensure a quality product. Strong leadership, global resources and U.S. based checking uniquely qualify Ovation to be your preferred partner.

## P2 Programs

**booth 1333**

Dripping Springs, Texas

**ph:** 512.858.2007

**toll free:** 800.563.6737

**www.p2programs.com**

P2 Programs means state of the art barcoding and tracking. We set the industry standard for quality barcoding and efficient tracking of structural steel from raw material receipt to erection on site. Employing P2 Programs' web-based product—STSX—you get instant, real-time information accessible from virtually any device. Since 1986, we've used Auto-ID technology to improve manufacturing process tracking. With our real-time update capabilities, we offer you the technological expertise and on-the-job experience needed for an affordable and successful solution to the challenges of manufacturing operations.



## Pacific Stair Corporation

**booth 1609**

Salem, Ore.

**ph:** 503.390.8305 | **toll free:** 800.477.8247

**www.pacificstair.com**

Pacific Stair Corporation, a leader in advanced stair system technology, has been located in Salem, Ore. for more than 30 years. Pacific Stair develops, manufactures, and provides a stair system that meets or exceeds current international building codes. Our stair systems are engineered to make the most efficient use of materials and labor, reducing costs and improving delivery times. Our customers know that we care about their schedule and required delivery dates.

## Pan Gulf Technologies

**booth 1305**

Thane West, Maharashtra

India

**ph:** 91.98.7022.2581

**www.pangulftech.com**

Pan Gulf Technologies is an ISO 9001:2015 certified multi-disciplinary engineering solutions company with specialization in structural and miscellaneous steel detailing, as well as connection design. As one of the top steel detailing companies globally, we use Tekla and SDS2 (350+ licenses) to produce 3D models and detailed fabrication and erection drawings for industrial, commercial, and infrastructure projects worldwide. Our strengths: 5,000+ projects delivered, size ranging from 50-50,000 tonnes, 600+ expert engineers, 20+ years of proven track record, six offices/delivery centers across the globe.

## Paramount Roll and Forming, Inc.

**booth 1641**

Bellflower, Calif.

**ph:** 562.944.6151 | **toll free:** 888.400.3883

**www.paramount-roll.com**

Celebrating 60 years of outstanding service and unparalleled capacity, Paramount Roll and Forming, Inc. specializes in the fields of aerospace, architectural, commercial, construction, entertainment, food, industrial, oil, public art, and pharmaceutical. We also specialize in curved staircases, including installation, heat induction bending, rolling for heavy plates, angles, tubes, pipes, and beams.

## PDM Steel

**booth 1664**

Elk Grove, Calif.

**ph:** 916.513.4548

**www.pdmsteel.com**

Established in 1954, and headquartered in Elk Grove, Calif., PDM Steel is a leading steel supplier with 10 service locations across the Western U.S. The company provides value-added processing services and distributes a full line of steel products across a broad range of industries.

## Peddinghaus Corporation

**booth 400**

Bradley, Ill.

**ph:** 815.937.3800

**www.peddinghaus.com**

Peddinghaus Corporation produces the toughest steel fabrication technology in the world. Every hand-assembled machine is the gold standard for what structural steel fabrication equipment should be. We understand that our machines are more than just a tool for our customers; they're the lifeblood of their company. We dedicate ourselves to working closely with fabricators throughout every step of their Peddinghaus experience—because when they succeed, we succeed together.

## Pioneer Machine Sales

**booth 351**

Rosenberg, Texas

**ph:** 832.509.1089

**www.pionermachinesales.com**

Pioneer Machine Sales represents the global leaders in metals fabrication and machining for manufacturing processes. We distribute machinery in Texas, Arkansas, Louisiana, and Oklahoma. With more than 20 years of experience in custom metal fabrication, our goal is to offer the newest innovations in machinery and manufacturing practices from around the world with the highest quality and lowest cost per part. We offer top-of-the-line brands from world class leaders in the industry, specializing in all types of products, from small-scale to large production manufacturing facilities.

## Power of Design Group, LLC

**booth 1824**

**www.podgrp.com**

## PPG Protective & Marine Coatings

**booth 1534**

Pittsburgh

**toll free:** 888.9PPGPMC

**www.ppgpmc.com**

PPG delivers protective coating solutions for a wide range of industries. Whether our customers need proven protection from corrosion, high temperatures, and fire, or want to ensure durability and aesthetic performance that will protect valuable assets, we have the advanced coating systems that can meet the specific needs of any environment.



**Precision Steel Systems**

**booth 551**  
Lincoln, Neb.  
**ph:** 402.413.7747  
[www.precisionsteelsystems.com](http://www.precisionsteelsystems.com)

Precision Steel Systems would like to introduce the PLS-624, a miscellaneous metal layout table for quick and accurate layout for railings, ladders, stair stringers, and more. With its ergonomic design for workers, simple programming, and economic price point, the PLS-624 will show quick return on investment for any shop looking for alternatives to making up for the skilled labor shortage.

**Procore**

**booth 2009**  
Carpenteria, Calif.  
**ph:** 952.807.5004  
[procore.com](http://procore.com)

Procure helps firms drastically increase project efficiency and accountability by streamlining and mobilizing project communications and documentation. This real-time data and accessibility minimizes costly risks and delays—ultimately boosting profits. Using our award-winning suite of project management tools, over 2 million registered Procure users across the globe manage all types of construction projects including industrial plants, office buildings, apartment complexes, university facilities, retail centers, and more.

**Prodevco Robotic Solutions Inc.**

**booth 832**  
Concord, Ontario  
Canada  
**ph:** 905.761.6155  
[www.prodevcoind.com](http://www.prodevcoind.com)

Prodevco Robotic Solutions offers advanced robotic plasma steel cutting systems. There are three models the PCR42, PCR41, and PCR 31 that will process standard structural steel profiles, and round tubes from 4 in. to 26 in., cuts copes, notches, holes and weld preps, splits beams, scribes and marks on all four faces of H-beams, channels, angles, and HSS and plates using automated robotic technology. The all-in-one system reduces fabrication time, manpower, and materials to meet everyone's goal: lower manufacturing costs.



**Project + Quality Solutions**

**booth 1955**  
Portland, Ore.  
**ph:** 503.550.9918  
[www.projectqualitysolutions.com](http://www.projectqualitysolutions.com)

At any stage of a project, PQS represents the project owner, contractor and fabricator to provide third party representation, interpret project specifications, deliver reasonable solutions, maintain project schedule, train and certify personnel, provide expert witness services, and maintain project schedule. For quality assurance, process planning and evaluation, quality control inspections, project management, and engineering, count on industry experts from PQS. We offer scalable resources, value engineering, project management/engineering, nondestructive testing, and dispute resolution.

**Qnect LLC**

**booth 1009**  
Hadley, Mass.  
**ph:** 413.387.4375  
[www.qnect.com](http://www.qnect.com)

Qnect partners with project teams to create early connected steel models. These early connected models contain more information than typical 3D models used for bidding. The supplemental information in an early connected model results in lower and tighter bids, helps reduce project schedules and cost overruns, and ultimately aids in expediting the process of designing, fabricating and erecting structural steel. To learn more about how structural steel project teams use Qnect, please visit: [www.qnect.com/customer-success-stories](http://www.qnect.com/customer-success-stories).

**Qualis Solutions, LLC**

**booth 1519**  
Highlands Ranch, Colo.  
**ph:** 303.493.5400  
[www.qualissolutions.com](http://www.qualissolutions.com)

The team at Qualis Solutions has over 30 years' experience detailing structures throughout the U.S. using AISC standards. Over the years, we've created drawings for a wide range of projects including office buildings, hospitals, schools, warehouses, and airports. Qualis is best known for our focus on miscellaneous metal detailing. Our team of 18 detailers have mastered the art of stairs, railing, canopies, balconies, and many other miscellaneous designs. You'll find us easy to work with and a reliable part of your project.

**Quality Emphasis Steel Solutions Pvt Ltd.**

**booth 1464**  
Thane, Maharashtra  
India  
**ph:** 973.536.2660  
[www.qessindia.com](http://www.qessindia.com)

QESS is an innovative steel detailing company dedicated to delivering high quality steel detailing services to steel fabricators, engineers, contractors and the construction industry since 2006. Quality, accuracy, efficiency and business integrity are the fundamentals we employ to ensure each job is done right the first time. Our total experience in detailing field can be counted at 36 years. QESS has been in business for nearly 20 years.

**Quality Management Company**

**booth 1866**  
Chicago  
**www.qmcauditing.com**

**Qubatic Steel Detailing LLC**

**booth 1560**  
Charleston, W.V.  
**ph:** 704.516.7074  
[www.qubatic.com](http://www.qubatic.com)

Qubatic is a progressive firm offering comprehensive steel detailing, connection design, estimation, and BIM modelling services. We recognize the importance of delivering great value and experience to our clients in every project. To meet these performance standards, we have worked hard over these 11 years to develop a technical expert team of detailers and checkers along with the cutting-edge technology required for modern-day needs with all required infrastructure in a spacious office space. Qubatic is an ISO 9001:2015 certified by TUV and an associate member of AISC and NISD.

**QuickFrames USA**

**booth 1521**  
Mesa, Ariz.  
**ph:** 480.656.1575  
[www.quickframes.com](http://www.quickframes.com)

QuickFrames is a leader in engineered structural steel roof frames for commercial construction, helping to speed and simplify the installation of mechanical equipment and structural framing on new construction and tenant improvement projects since 2015. Its award-winning bolt-in frames and drop-in frames are proven to save customers time and hassle with jobsite coordination while eliminating common delays with traditional angle iron framing options. QuickFrames offers engineering, award-winning service, fast production, and delivery to the U.S. and Canada.



**R.J. Watson, Inc.**

**booth 1731**  
Alden, N.Y.  
**ph:** 716.901.7020  
[www.rjwatson.com](http://www.rjwatson.com)

R. J. Watson, Inc. delivers a diverse and custom range of products and services to customers around the world, providing high load, multi-rotational bearings, seismic isolation devices, and expansion joint systems to the bridge, highway and heavy construction industry.

**Radley LLC**

**booth 1105**  
[www.radley.com/steel](http://www.radley.com/steel)

**Ray Fu Enterprise Co., Ltd.**

**booth 1953**  
Kaohsiung  
Taiwan R.O.C.  
**ph:** 886.7.556.0180  
[www.ray-fu.com](http://www.ray-fu.com)

Ray Fu was founded in 2000 to market steel wires and fasteners to the global market as a professional screw manufacturer and exporter. The company has facilities ranging from wire processing plants, fastener factories, heat treatment factories, and packaging warehouses. Ray Fu produces screws geared for the construction and automotive industries and wires for manufacturing fasteners. Aiming at providing superior quality, Ray Fu is ISO 9001, ISO 14001, IATF16949 and AS 9100D certified to meet customers' demands.

**Republic Steel**

**booth 750**  
[www.republicsteel.com](http://www.republicsteel.com)

Color Key:

- Bridge Pavilion Exhibitor
- Heavy Machinery Area
- Safety Pavilion Exhibitor

## exhibitor list :: NASCC: THE STEEL CONFERENCE

### REX Engineering Group booth 1651

Naperville, Ill.  
ph: 630.318.1725  
[www.rexeg.com](http://www.rexeg.com)

REX Engineering Group (previously known as REX Conn Design) is a multi-disciplinary engineering firm focused on structural, MEP, and connection and construction engineering, also providing construction services and technology solutions. Our engineers are experts with decades of experience in a wide variety of market sectors and project types across the U.S. and Canada. Our designs are efficient and economical, always focused on project budgets. We view every project as a unique solution, looking for opportunities to advance new ideas and technologies. We pride ourselves on our commitment to our clients and projects.

### RISA

#### booth 911

Foothill Ranch, Calif.  
ph: 949.951.5815 | toll free: 800.332.7472  
[www.risa.com](http://www.risa.com)

RISA has been developing leading-edge structural design and optimization software for over 30 years. Our products are used by 24 of the top 25 U.S. design firms in more than 70 countries around the world for towers, skyscrapers, airports, stadiums, petrochemical facilities, bridges, roller coasters, and everything in between. The seamless integration of RISAFloor, RISA-3D, RISAFoundation and RISAConnection creates a powerful, versatile, and intuitive structural design environment, ready to tackle almost any design challenge.

### Scotchman Industries, Inc.

booth 126  
Philip, S.D.  
ph: 605.859.2542  
[www.scotchman.com](http://www.scotchman.com)

Scotchman Industries is the most trusted hydraulic ironworker manufacturer in the U.S. (45 to 150 tons) and also builds a complete line of circular cold saws: manual to fully automatic and a line of hydraulic presses: 66 to 176 ton. Scotchman also distributes a complete line of digital measuring systems, tube and pipe notchers/grinders, and a band saw.

### Scougal Rubber Corp.

booth 1751  
McCarran, Nev.  
ph: 775.284.8500  
[www.scougalrubber.com](http://www.scougalrubber.com)

Manufacturer of bridge bearing pads, assemblies, and complex steel bridge bearing components. AISC and NTPEP certified.

### SDS2 by ALLPLAN

booth 915  
Lincoln, Neb.  
ph: 402.441.4000  
toll free: 800.443.0782  
[www.sds2.com](http://www.sds2.com)



**SDS2**  
BY ALLPLAN

SDS2 is a leading provider of steel design software. A product of ALLPLAN, we support steel projects in the BIM cycle from design to construction and empower our users to deliver at the highest levels of quality and efficiency.

### Seismic Bracing Company

booth 2022  
Salt Lake City  
ph: 801.550.7745  
[www.thesbcllc.com](http://www.thesbcllc.com)



We are makers of Buckling Restrained Brace (BRBs), the state of the art braces for bracing buildings and other structures during earthquakes. As the name implies, BRBs do not buckle. They smash and stretch axially absorbing seismic energy. We have patented a simple, easy and repeatable methods to manufacture BRBs, which brings better value to projects. Our methods have been fully tested and exceed governing building code requirements. All our projects to date have been a great success for our clients and us.

### SEU (formerly SE University) by SE Solutions

booth 2059  
Holland, Mich.  
ph: 616.836.1702  
[www.LearnWithSEU.com](http://www.LearnWithSEU.com)

SEU (formerly SE University) helps structural engineers get high quality continuing education via web seminars in a format that is economical and easy to use. Every subscription includes access to both live sessions, as well as past session recordings through the SEU Learning Portal. In addition, subscribers get access to the "EIT Ramp Up" series to help younger engineers become productive faster. Provide the benefit of ongoing education to your engineers by participating in SEU!

### Seyco Joist

booth 750  
Houston  
ph: 346.500.3605  
[seycojoist.com](http://seycojoist.com)

Structural steel fabricators (steel joist, steel deck, and structural facilities).

### Shandong Hanpu Machinery Industrial Co., LTD

booth 1752  
Jinan City, Shangdong  
China  
ph: 86.531.8353.0737  
[www.hanputool.com](http://www.hanputool.com)

China's most professional Electric Torque wrench and Shear wrench manufacturer. Accept customized production. Newly products keep on the way.

### Sherwin-Williams Protective and Marine

booth 1735  
Cleveland  
ph: 216.566.2000 | toll free: 800.524.5979  
[protective.sherwin.com](http://protective.sherwin.com)

Sherwin-Williams Protective and Marine coatings are ideal for shop application and available through its over 4,700 distribution locations. Our Sherwin-Williams NACE and SSPC-certified corrosion experts ensure that your projects use technologies that reduce the critical planned timeline and achieves its expected service life. For more information, contact us at [swprotective@sherwin.com](mailto:swprotective@sherwin.com).

### Shop Data Systems, Inc.

booth 1508  
[www.shopdata.com](http://www.shopdata.com)

### Short Span Steel Bridge Alliance booth 1762

Washington  
ph: 202.452.7100  
[www.shortspansteelbridges.org](http://www.shortspansteelbridges.org)

The Short Span Steel Bridge Alliance (SSSBA) is a group of bridge and buried soil steel structure industry leaders who have joined together to provide educational information on the design and construction of short span steel bridges in installations up to 140 ft in length.

### SidePlate / MiTek

booth 1423  
Mission Viejo, Calif.  
ph: 949.238.8900  
[www.mii.com](http://www.mii.com)

SidePlate™ Connection Designs and engineering services are now part of the MiTek® portfolio of solutions. MiTek is a platform innovator and enabler that exists to transform the building industry with better building solutions. Our software, services, engineered products, and automation enable our customers and partners to transform the way they design, make, and build. SidePlate Connection Designs put steel where a building needs it to reduce the overall tonnage, minimize required connections, and accelerate erection times.

### SigmaNEST

booth 2108  
[www.sigmanest.com](http://www.sigmanest.com)

### Simpson Strong-Tie Co.

booth 1215  
Pleasanton, Calif.  
ph: 925.560.9000  
toll free: 800.999.5099  
[www.strongtie.com](http://www.strongtie.com)



Simpson Strong-Tie, one of the largest suppliers of structural building products and technology in the world, is dedicated to helping build safer and stronger structures. We offer the commercial steel industry a suite of products backed by research, development, and rigorous testing, combined with our software offerings and services.

### SketchDeck.ai

booth 2140  
Edmonton, Alberta  
Canada  
ph: 780.200.7412  
[www.sketchdeck.ai](http://www.sketchdeck.ai)



SketchDeck.ai is focused on accelerating automation in the construction industry. We have developed LIFT, an automated material take-off software that is changing the way estimators work in the steel industry. It is the first solution for structural steel take-offs that uses AI and machine learning to identify beams and other structural elements automatically from 2D engineering drawings. LIFT saves estimators by automating tedious, manual, and repetitive tasks in take-offs. With LIFT, what used to take hours can now be done in a matter of minutes, reducing human error and ensuring accuracy and efficiency in the estimation process.



### Skidmore-Wilhelm

**booth 1341**

Solon, Ohio

**ph:** 216.577.5930

[www.skidmore-wilhelm.com](http://www.skidmore-wilhelm.com)

For more than 70 years, Skidmore Wilhelm has been the standard tool to verify bolting methods (pre-installation verification). Recently, we have developed an online training program to save time and help iron workers to do their jobs safely. Please visit our training site at [www.skidmore-training.com](http://www.skidmore-training.com). We are also the world's leading supplier of devices to test impact wrenches.

### Smithwick Engineering

**booth 1858**

Corpus Christi, Texas

**ph:** 361.229.4835

[www.smithwickeng.com](http://www.smithwickeng.com)

Smithwick Engineering is a professional engineering firm that specializes in on-site observation and dimensional survey for a broad range of material handling appliances. We specialize in overhead cranes and runways, specialized lifting appliances, jibs and monorails, and BTH lifting devices. Our team is trained to support from concept development to final installation and testing. With a skilled team of project managers, professional engineers, inspectors and surveyors, we can support all material handling needs from cradle to grave.

### Soitaab USA Inc.

**booth 120**

Naperville, Ill.

**ph:** 312.856.6970

[www.soitaabusa.com](http://www.soitaabusa.com)

Since 1938, Soitaab has been a world leader in the manufacture of CNC plasma, flame, laser and water jet cutting machines. Soitaab's equipment offerings range from simple plug-and-play machines to highly engineered all-in-one heavy fabrication lines. Our machines can be equipped with several accessories such as drilling and tapping units, surface and hole milling, bevel heads for welding prep, countersinking, marking, pipe and dome cutting, sophisticated handling systems, and many others.

### South Atlantic Galvanizing

**booth 1442**

[www.southatlanticllc.com](http://www.southatlanticllc.com)

### SprayTec Coating Solutions, LLC

**booth 1763**

Suwanee, Ga.

**ph:** 404.386.3652

[www.sprayteccoat.com](http://www.sprayteccoat.com)

SprayTec Coating Solutions provides "One Source" for your industrial service solutions. SprayTec offers a broad range of field and shop applied surface technology solutions including: thermal spray/metalizing, specialty coatings and linings, epoxy and plural coating systems, safety traction/anti-skid, atmospheric and chemical corrosion, abrasive blasting surface preparation, and lead and asbestos abatement. Union and open shop non-union operations through teaming efforts.

### St. Louis Screw & Bolt

**booth 1209**

Madison, Ill.

**ph:** 314.389.7500 | **toll free:** 800.237.7059

[slbolt.com](http://slbolt.com)

Selling direct to structural steel fabricators, St. Louis Screw & Bolt is one of the oldest structural bolt manufacturers in the U.S. Specializing in ASTM F3125 heavy hex and tension control structural bolts in grades A325/F1852/120ksi and A490/F2280/150ksi, types I and III, plain, mechanically galvanized, hot dip galvanized, F1136 and F2833 coatings. St. Louis Screw & Bolt also has a very large inventory of other construction fasteners including anchor bolts, weld studs, and concrete anchors, just to name a few.

### Stainless Structural America

**booth 2013**

Conroe, Texas

**ph:** 936.538.7600

[www.stainless-structurals.com](http://www.stainless-structurals.com)

Stainless Structural is a global producer and supplier of sharp cornered stainless steel and carbon steel structural shapes and special custom profiles. Our standard stainless steel sections replicate the dimensions of the A6 carbon steel platform. Through a multitude of production technologies, including laser welding and extruding, we continue to be a world leader in stainless steel structural shapes and steel profiles. Our value added services include customizations, fabrication, polishing, and more. No matter the size and scope of your project, we can provide the best steel solutions for your project's designs and demands.



### Steel and Pipe Supply

**booth 1530**

[www.SteelAndPipe.com](http://www.SteelAndPipe.com)

### Steel Deck Institute

**booth 2058**

Florence, S.C.

**ph:** 412.487.3325

[www.sdi.org](http://www.sdi.org)

Founded in 1939, the Steel Deck Institute (SDI) is a trade association representing steel deck manufacturers and those manufacturing products used in conjunction with steel deck. The SDI actively publishes design manuals, develops standards for steel roof and floor deck, offers website tools, provides an industry standard EPD, offers educational opportunities, and supports research related to steel deck. Our most recent publications are the 2022 ANSI Standards. These include the new and combined ANSI/SDI SD-2022, and the renewed ANSI/SDI T-CD-2022 and ANSI/SDI QA/QC-2022.

### Steel Dynamics Long Products Group

**booth 1109**

Columbia City, Ind.

**ph:** 260.625.8100 | **toll free:** 866.740.8700

[lpg.steeldynamics.com](http://lpg.steeldynamics.com)

Steel Dynamics, Inc. is one of the largest domestic steel producers and metals recyclers in the U.S. based on estimated annual steelmaking and metals recycling capability, with facilities located throughout the U.S. and in Mexico. Steel Dynamics produces steel products, including hot roll, cold roll, and coated sheet steel, structural steel beams and shapes, rail, engineered special-bar-quality steel, cold finished steel, merchant bar products, specialty steel sections and steel joists and deck.

### Steel Erectors Association of America

**booth 1862**

Winston-Salem, N.C.

**ph:** 336.294.8880

[www.seaa.net](http://www.seaa.net)

The Steel Erectors Association of America (SEAA) is dedicated to advancing the common interests and needs of all engaged in building with steel. Objectives include the promotion of safety, education and training programs for steel erector trades; development and promotion of standards; and cooperation with others in activities which impact the commercial construction business. SEAA develops strategic partnerships and works closely with industry groups to provide members with industry representation steel design, engineering, fabrication, labor, safety, and training groups.

### Steel Founders' Society of America

**booth 1466**

[www.sfsa.org](http://www.sfsa.org)

### Steel Joist Institute

**booth 1959**

Florence, S.C.

**ph:** 843.407.4091

[www.steeljoist.org](http://www.steeljoist.org)

The Steel Joist Institute (SJI), a nonprofit organization of active joist manufacturers and other organizations and companies connected to the industry, was founded in 1928 to address the need for uniform joist standards within the industry. Today, the SJI continues to maintain the standards for steel joist construction. In addition, the SJI provides educational opportunities for construction professionals utilizing a library of printed publications and live and recorded webinars. We also offer assistance in identifying existing joists in buildings undergoing retrofit.

Color Key:

Bridge Pavilion Exhibitor

Heavy Machinery Area

Safety Pavilion Exhibitor

## exhibitor list :: NASCC: THE STEEL CONFERENCE

### Steel Plate

booth 343

Pendergrass, Ga.

ph: 888.894.8818

[www.steelplate.us](http://www.steelplate.us)

Steel Plate Ohio is located in Streetsboro, Ohio, right outside of Cleveland. This location offers (4) oxy-fuel machines, (1) plasma machine, and (6) overhead cranes with up to 35-ton capacity and the capability to burn plates up to 20 in. thick. Steel Plate Georgia currently offers (7) oxy-fuel machines, (1) plasma machine, (2) Quickmill Intimidators, (2) Quickmill Annihilators, (5) overhead cranes with up to 40-ton capacity, and railcar access. Our oxy-fuel machines offer table space ranging from 10 ft to 20 ft wide and up to 60 ft long, while our plasma machine offers a 24 ft by 83 ft table, making no job too big to handle!



### Steel Plus Network

booth 1705

Irishtown, New Brunswick

Canada

ph: 902.384.5924

[www.steelplus.com](http://www.steelplus.com)

Steel Plus Network has traditionally organized meetings for members to provide opportunities for improvement to each of their operations through educational presentations, motivational messages, and industry expert reports. These meetings also fulfill our mission to coordinate our purchasing programs and networking opportunities. The regional meetings conducted by SPN along with the annual general meeting are deemed vital to the health and welfare of SPN's members and are considered an integral part of our operation.

### Steel Projects Corp.

booth 425

Forrest Hill, Md.

ph: 334.743.11730

[www.steelprojects.com](http://www.steelprojects.com)

Steel Projects is a company that has been editing software solutions for steel fabricators since 1994. We offer a complete, digitalized and optimized management of steel fabricators' shop floors, including both CNC machines and manual workstations. Our main features include: project and production management, section and plate nesting, automatic CNC programming, live production monitoring, stock and purchasing management, and traceability management. Some of them are available on a dedicated Android mobile application. Today, our ambition is to remain one of the world leaders in the field.

### Steel Tek Unlimited

booth 1346

Eden Prairie, Minn.

ph: 612.258.7531

[www.steelteku.com](http://www.steelteku.com)

Steel Tek Unlimited is a leading-edge company in the steel industry that specializes in customizing CAD programs and offers steel detailing to fit your needs. We are proud to say that all our work is done in the U.S. with an experienced team of people from the bridge, industrial, and commercial industries who understand today's construction market.

### Steel Tube Institute

booth 1616

[www.steeltubeinstitute.org](http://www.steeltubeinstitute.org)

### Steelmax Tools LLC

booth 126

Littleton, Colo.

ph: 303.690.9146

[www.steelmax.com](http://www.steelmax.com)

Steelmax delivers high-quality solutions to the steel fabrication industry. Equipped with a premium line of metal cutting saws, magnetic drilling machines and accessories we acquired notoriety and diligently served customers. We have expanded the product portfolio for the purpose of covering more aspects of the metal fabrication industry. Our current portfolio includes a full range of plate and pipe beveling solutions, welding automation and mechanization equipment, hydraulic punches, and lifting magnets. Today, Steelmax is an international brand sold through industrial and welding distributors around the world.

### SteelSUB, LLC

booth 2111

[steelsub.com](http://steelsub.com)

### Steelweb Inc.

booth 2041

Coral Springs, Fla.

ph: 954.757.3520 | toll free: 888.965.6660

[steelweb.com](http://steelweb.com)

Steelweb Inc. is a Florida-based company with over 30 years of experience in providing top-notch steel detailing services. We specialize in 3D detailing for a wide range of industrial and commercial projects, from schools and hospitals to offices. Our team of 60 detailers excels in project management, BIM coordination, BIM collaboration, estimodeling, and design-build services. We're experts in using Tekla and SDS2 software and seamlessly integrate with Strumis, Tekla PowerFab and AGT Robotics, as well as Autodesk ReCap and BIM360.

### Structural Engineering Institute of ASCE

booth 2035

Reston, Va.

ph: 703.295.6195

[www.asce.org/SEI](http://www.asce.org/SEI)

Join more than 30,000 members of the Structural Engineering Institute of ASCE to connect, learn, advance your career, and build the future of the structural engineering profession. SEI stimulates technological advancement, improves professional practice, and drives the practical application of cutting-edge research. ASCE AMPLIFY: Expanding Knowledge Into Practice This new digital platform features interactive functionality that makes it easier for civil engineers to put ASCE standards into practice. Visit [amplify.asce.org](http://amplify.asce.org) for more. Join or renew your ASCE/SEI Membership today at [www.asce.org/SEIMembership](http://www.asce.org/SEIMembership) Experience your future [www.futureworlddivision.org](http://www.futureworlddivision.org)

### Structural Stability Research Council (SSRC)

booth 1864

Chicago

ph: 312.670.7015

[www.ssrcweb.org](http://www.ssrcweb.org)

The Structural Stability Research Council is a technical organization that focuses on the state-of-the-art understanding of the impact of stability related issues on the analysis, design, and behavior of metal structures. SSRC is comprised of engineers, educators, and industry members with an interest in stability related issues.

### Structures Online

booth 2135

Tempe, Ariz.

ph: 602.563.5958

[www.structuresonline.net](http://www.structuresonline.net)

Established in 2000, Structures Online (SOL) is the oldest AISC steel detailing and structural engineering firms operating out of India. At 550+ member strong, SOL is also one of the largest in the industry. Through our decades of experience, we have built up an unmatched wealth of knowledge capital. Our senior leadership has seen just about everything there is to see. And because of our high retention of top and experienced talent along with recording of all technical information to train new staff, that knowledge is preserved at SOL to be effectively utilized when the need arises.



### STRUMIS LLC

booth 1029

Collegeville, Pa.

ph: 610.280.9840

[www.strumis.com](http://www.strumis.com)

STRUMIS LLC is the world's leading developer of steel fabrication management software. The most comprehensive and powerful end-to-end solution available to fabricators globally, we operate in more than 50 countries. Our products, which include steel estimating, fabrication information and production management, and project collaboration tools work seamlessly with third-party software and have consistently transformed our customer's businesses within the structural steel construction supply chain. STRUMIS connects, streamlines, and simplifies all of your steel fabrication projects and resources.

### Struzon Technologies Inc.

booth 1727

New York

ph: 646.992.3826

[struzon.com](http://struzon.com)

Struzon, a trusted structural steel detailing/engineering service partner to the construction industry and we are an organization that wears numerous caps. From being market pioneers of structural detailing, engineering, design, and research, to do well architectural results in both residential and industrial divisions, we are enlisting our company in different arenas.



## exhibitor list

### Stubbs Engineering, Inc.

booth 1562

Las Cruces, N.M.

ph: 575.993.5228

[www.stubbseng.com](http://www.stubbseng.com)

Stubbs Engineering, Inc. delivers cost-effective and efficient structural designs to our clients. Our primary focus is providing accurate and expedited drawings, ensuring project timelines are met. With our deep knowledge in both design and construction methods, our firm goes above and beyond traditional structural firms. Leveraging our expertise in structural design, we assist clients in resolving any construction-related issues that arise. We offer integrated construction design and shop drawing packages, providing a comprehensive and holistic approach to projects. To best serve our clientele, we are licensed in 36 states, with more to come.

### Sugar Steel Corporation

booth 2004

[www.sugarsteel.com](http://www.sugarsteel.com)

### Sumter Coatings, Inc., an Ergon Company

booth 1923

Sumter, S.C.

ph: 803.481.3400 | toll free: 888.471.3400

[www.sumtercoatings.com](http://www.sumtercoatings.com)

Sumter Coatings is a manufacturer of premium industrial and specialty coatings, with a strong emphasis on corrosion resistant primers, intermediates and topcoats for structural and miscellaneous steel. Sumter Coatings is dedicated to producing coatings that protect, beautify, renew, and extend the life of our customer's assets while meeting or exceeding the stringent specifications required by today's architects and engineers.

### Superior Glove

booth 1855

Acton, Ontario

Canada

ph: 800.265.7617

[superiorglove.com](http://superiorglove.com)

Superior Glove is a leading innovator in the design and manufacture of safety gloves and sleeves. Their products protect workers across the globe in many major industries, including construction, oil and gas, mining, and manufacturing.

### Swisher Tools, LLC

booth 2118

[www.swishertools.com](http://www.swishertools.com)

Color Key:

Bridge Pavilion Exhibitor

Heavy Machinery Area

Safety Pavilion Exhibitor



**ST. LOUIS**  
SCREW AND BOLT



#### ENJOY THE SAME GREAT SERVICES

- ◆ OVER-THE-TOP WRAPPING
- ◆ PALLET MAPPING
- ◆ HEXPORT®
- ◆ RPK® - RIGID POLYETHYLENE KEGS
- ◆ ONE & TWO DAY SHIPPING NATIONWIDE

Call or email us your inquiry!

**St. Louis Screw & Bolt**

[sales@SLBolt.com](mailto:sales@SLBolt.com)

800-237-7059

**Connecting amazing structures Nationwide!**

ATLANTA  LAS VEGAS  ST LOUIS

## INTRODUCING NEW 32" WIDE N DECK

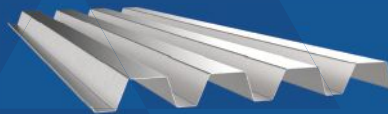

NS32\*

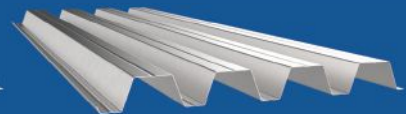

NS32-XS - Extra Strength (with stiffeners)\*

\*Interlocking side laps also available

**Save time and labor costs with the  
strongest N deck profile in the industry**

Fewer sheets saves hoisting and spreading time

Less side lap connections saves labor and reduces installation time

Wider sheet results in higher  
diaphragm capacity

Low flute geometry allows for  
easier Hilti pin installation



**LEARN MORE AT CSCSTEELUSA.COM**

**TCI Coatings**

**booth 2016**  
Lubbock, Texas  
**ph:** 806.762.0871  
[fenixspc.com](http://fenixspc.com)

Everyday, Fenix Specialty Coatings (Fenix Group) and our brands work together to design the present, protect the future, and make the impossible achievable. Fenix Group brands are industry's most trusted problem solvers for specialty performance coatings. It is our mission to fulfill our customers' needs with the highest-quality, most durable, and innovative specialty performance coating products, and to deliver superior technical expertise that exceeds expectations while offering an exceptional customer service experience. [www.tci-coatings.com](http://www.tci-coatings.com) | [www.sierrapaint.com](http://www.sierrapaint.com) [www.burkeindustrialcoatings.com](http://www.burkeindustrialcoatings.com)

**TDS Industrial Services Ltd.**

**booth 1528**  
Surrey, British Columbia  
Canada  
**ph:** 604.599.1570 x10  
[www.tdsindustrial.com](http://www.tdsindustrial.com)

TDS—where BETTER IS OUR STANDARD. TDS has been in the steel detailing business for more than 40 years and continues to service our steel fabrication customers by providing exceptional value with certainty and confidence. Being an ISO 9001:2015 certified company, we understand the need to manage and mitigate risks associated with offshore detailing and have developed a system and procedures to have 100% control over all aspects of projects. From the smallest miscellaneous projects to the heavy industrial, we have the team to do it all.

**Team Detailing Solutions LLC**

**booth 1952**  
Jackson, N.J.  
**ph:** 913.674.4485  
[teamdetailing.com](http://teamdetailing.com)

Team Detailing Solutions (TDS) has specialized in structural steel detailing, connection design and estimating in its 18 years in business. We operate SDS2 and Tekla Structure, Autodesk, Descon, Mathcad (90+ licenses) to produce 3D models and detailed fabrication and erection drawings for industrial, commercial, and infrastructure projects in AISC/CISC standards with a team of 180+ detailers, checkers, and project managers. They are capable of completing projects small/large and complex structures. We provide connection/delegated miscellaneous stamp calculations with Certified American PE stamp.

**Techflow Inc.**

**booth 1553**  
Duluth, Ga.  
**ph:** 205.228.0960  
[www.techfloweng.com](http://www.techfloweng.com)

Techflow Inc., based in Duluth Ga., with support staff located in our offices in India, offers the best in 3D steel detailing, BIM coordination, connection design, pre-detailing setup, and estimating. With project management/coordination in Duluth coupled with 400 detailers and checkers in India, we provide the best in U.S. quality and competitive pricing, using Tekla, SDS2 and BoCad. Techflow holds AISC and NISD memberships, with NISD IDC-certified detailers on staff. Techflow is a QPP-certified company as recognized by the NISD ensuring quality detailing to your standards, on time.

**Tectonix Steel, Inc.**

**booth 1359**  
Orem, Utah  
**ph:** 801.377.0315  
[www.tectonixsteel.com](http://www.tectonixsteel.com)

Tectonix Steel offers more than 30 years of experience providing the highest quality steel detailing using the latest technology. We are an established detailing firm with the ability to handle virtually any size job. We specialize in structural and industrial projects ranging from 200 tons to 3,000 tons.

**Terracon Consultants, Inc.**

**booth 1811**  
Olathe, Kan.  
**ph:** 913.599.6886 | **toll free:** 800.593.7777  
[www.terracon.com](http://www.terracon.com)

Terracon's materials testing and inspection professionals are ready to journey with you and help you reach your goal. Since our founding in 1965, Terracon has become a thriving, employee-owned, multidiscipline engineering consulting firm. Our real-time, data-driven insights and innovations create an unmatched client experience that spans the lifecycle of any project from earth to sky.

**TFe Connection Nr. America**

**booth 1711**  
Singapore  
Singapore  
**ph:** 503.841.2643  
[www.tfeconnection.com](http://www.tfeconnection.com)

TFe Connection was established to directly support fabricators in Australia, North America, Europe, and Asia Pacific by taking advantage of the value engineered benefits of welded beams and custom BU sections. We have more than a decade of experience of supporting the Australian and New Zealand markets, and the capability to produce welded beams and built-up sections that meet your projects rigorous requirements. TFe Connection is ready to extend its direct support to fabricators across the North American market.

**Threaded Fasteners, Inc.**

**booth 1749**  
Mobile, Ala.  
**toll free:** 800.345.4976  
[threadedfasteners.com](http://threadedfasteners.com)

Threaded Fasteners Inc. is 100% employee owned and specializes in the manufacturing, custom packaging, and distribution of steel fasteners, including A325 structural bolts, anchor bolts, nuts, washers, and more. Our manufacturing capabilities include bent anchor bolts, j bolts, structural bolts, single and double end studs, and more in plain and galvanized. We can even provide parts that are 100% melted and manufactured in the U.S. With more than 350 dedicated employee owners, \$14 million in inventory, and 16 locations from Alabama, Mississippi, Florida, Oklahoma, Tennessee, Georgia, and Texas, we can meet the global needs of our customers.

**Threadline Products, Inc.**

**booth 2018**  
Charlotte, N.C.  
**ph:** 704.527.9052  
[threadlineproducts.com](http://threadlineproducts.com)

FAST. FLEXIBLE. AT YOUR SERVICE. Threadline Products, Inc. has supplied threaded products and miscellaneous steel to the construction industry since 1984. We can furnish any bolt or fastener for commercial building construction and concrete; F1554 anchor bolts, A325 structural connection bolts, grade 5/8 bolt, socket headed bolts, rebar and more. Threadline has carbon, stainless and alloy material in stock ready to fabricate and meet your custom requirements with expert welders on our fabrication team. With one- or two-day shipping available to more than half the U.S., our speed is unmatched. We are DBE/HUB certified.

**TorcUP Inc.**

**booth 1467**  
Easton, Pa.  
**ph:** 610.250.5800 | **toll free:** 888.TORCUP.1  
[www.torcup.com](http://www.torcup.com)

Industrial Bolting Tools—made in the USA — TorcUP understands bolting is more than tightening and loosening. It's ingenuity, reliability, and safety. That's why it's important to us that we work with you to create the best solutions for your application's needs through onsite demonstrations for sales, service, and rentals.

**Totten Tubes, Inc.**

**booth 1662**  
Azusa, Calif.  
**ph:** 626.812.0113 | **toll free:** 800.882.3748  
[www.tottentubes.com](http://www.tottentubes.com)

With a huge depth of inventory and wider range of in-stock products than any of our competitors, Totten Tubes is the most diversified and specialized steel tube and steel pipe distributor in the U.S. We are committed to being a true one-stop-shop for all your needs. Totten markets throughout North America with stocking warehouses in Los Angeles, San Diego, Phoenix, Northern California, and Vancouver, Wash. Totten offers in-house precision saw cutting and state-of-the-art laser tube cutting.

Color Key:

- Bridge Pavilion Exhibitor
- Heavy Machinery Area
- Safety Pavilion Exhibitor



**Trilogy Machinery, Inc.**

**booth 1050**  
 Belcamp, Md.  
**ph:** 410.272.3600 | **toll free:** 888.988.ROLL  
[www.TrilogyMachinery.com](http://www.TrilogyMachinery.com)

Trilogy Machinery, Inc. is the exclusive North American distributor for Swebend bending rolls as well as the exclusive U.S. distributor for Sunrise Ironworkers including CNC models, LEMAS plate bending rolls, BSP tube punching systems, and U.S. distributor for Synergy Bending Rolls. Trilogy offers sales, service, and support for every brand it sells from its Maryland headquarters and local dealers around the country.

**Trimble**

**booth 1123**  
 Kennesaw, Ga.  
**ph:** 770.426.5105 | **toll free:** 877.TEKLA.OK  
[www.tekla.com/us](http://www.tekla.com/us)

Tekla software solutions from Trimble power the construction industry by providing technology needed to increase performance, reduce costly errors and promote greater collaboration on projects. Users can produce high-quality 3D models and construction documentation—as well as create and manage structural analysis, design, detailing and fabrication data. Designed with a commitment to improve digital construction information workflows, Tekla software gives a true competitive edge to construction industry professionals.

**Triple-S Steel / Intsel Steel**

**booth 1317**  
 Houston  
**ph:** 713.697.7105 | **toll free:** 800.231.1034  
[www.sss-steel.com](http://www.sss-steel.com)

Triple-S Steel Holdings is a family of steel service centers. You know us through our structural steel brands: Triple-S Steel Supply and Intsel Steel Distributors. Our full-line service centers keep over 200,000 tons of inventory in stock. Beams, plate, and other structural materials are our stock in trade, and the fabricator is our partner to get more steel into buildings every day. We are proud to support the AISC in its mission of promoting the use of steel! Triple-S is helping our customers by modernizing our equipment and how we process materials before it leaves our facility. Give us a call to find out more!

**TRU-FIT PRODUCTS**

**booth 1950**  
[tfcpcorp.com](http://tfcpcorp.com)

**TurnaSure, LLC**

**booth 1437**  
 Langhorne, Pa.  
**ph:** 215.750.1300 | **toll free:** 800.525.7193  
[www.turnasure.com](http://www.turnasure.com)

TurnaSure's ViewTite® self-indicating Direct Tension Indicator is accepted and specified as the preferred self-indicator on a growing number of major structural steel projects. Its innovative and unique design is a winner for the 2022 America Fastener Innovation Award (FIA). Inspection is quick, easy, and reliable. "Green Means Go". ViewTite is a part of the world's most comprehensive product line of Direct Tension Indicators. DTIs provide a cost-effective solution to tensioning high-strength bolts, studs, and anchors. All TurnaSure DTIs are proudly manufactured in the U.S. to ASTM and EU Standards.

**Unite3D Inc.**

**booth 2122**  
 Albion, N.Y.  
[www.unite3d.com](http://www.unite3d.com)

Unite3D connects SDS2 users working remotely via a central model hosted in the cloud. We provide affordable, scalable cloud infrastructure. Whether you want to connect with remote workers anywhere in the world or replace your sluggish local office server with a fast, robust cloud network without the upfront cost of a powerful server—Unite3D can help you reach your potential at a fraction of the cost of other cloud services! [NASCCinfo@unite3d.com](mailto:NASCCinfo@unite3d.com)

**United Structure Detailing Inc.**

**booth 2055**  
 Los Angeles  
**ph:** 480.409.1500  
[unitedstructuredetailing.com](http://unitedstructuredetailing.com)

Quality assurance : on-time delivery : effective coordination—United Structure Detailing Inc. (USD Inc.), offers steel structure and miscellaneous detailing—connection design with PE stamped (all states) services. We specialize in crafting detailed shop drawings, 3D models, BIM, erection plans, etc. USD also provides NCI, IFC, CNC, DXF, DSTV, ENC, KSS, reports, and other supporting production files. USD holds both AISC and NISD memberships. Our team of seasoned professionals (detailers, checkers, and project managers) equipped with advanced software and technologies ensures we will meet the quality and schedule.

**V&S Galvanizing**

**booth 1034**  
 Columbus, Ohio  
**ph:** 800.801.3648  
[www.hotdipgalvanizing.com](http://www.hotdipgalvanizing.com)

V&S Galvanizing is a leader in the hot-dip galvanizing industry, with eight locations on the East Coast and Midwest. Specializing in corrosion protection of steel with zinc by hot-dip galvanizing. We offer the DUROZINQ system of galvanizing, packaging, tagging, and guaranteed service. We also offer our COLORZINQ system (paint over galvanizing) that adds brilliant color to a base of corrosion protection. V&S offers trucking and many other value added services. V&S Galvanizing is part of Voigt & Schweitzer LLC, a holding of Hill & Smith Holdings, PLC.

**Valmont Coatings**

**booth 1708**  
 Omaha, Neb.  
**ph:** 402.359.6145  
[www.valmontcoatings.com](http://www.valmontcoatings.com)

As a full-service coatings company, Valmont Coatings provides quality surface finishes that extend the service life and improve the appearance of metal products throughout the country. In fact, Valmont Coatings is one of the largest custom galvanizers in North America. Our processes and transportation capacities are designed to efficiently handle steel products of all shapes and sizes for customers anywhere in the country.

**Vectis Automation**

**booth 242**  
 Loveland, Colo.  
**ph:** 970.852.5200  
[www.VectisAutomation.com](http://www.VectisAutomation.com)

Vectis Automation designs and integrates cobot metal fabrication solutions to help structural steel fabricators boost productivity amid the skilled labor shortage. Come see our easy-to-use, affordable, and versatile Cobot Welding Tool and Cobot Plasma Cutting Tool that let you quickly start automating simple, repetitive parts—freeing up your team for more complex weldments or other value-add tasks. We look forward to meeting you and starting a conversation. We always begin by taking an in-depth look at your application(s) to make sure they are a good fit for automation.

**Vegazva Technologies**

**booth 1265**  
 Rolling Meadows, Ill.  
**ph:** 630.883.4354  
[www.vegazva.com](http://www.vegazva.com)

Vegazva (ISO 9001:2015) is an IL-based engineering design and detailing company and a member of NISD and AISC. With PE stamping capabilities in all states, we provide services for estimation, main, and misc. steel, commercial and industrial projects across the country through our steel detailing division. Our plant design division caters to mineral, chemical, water and wastewater, oil and gas, petrochemical, and pharma industry. With over 250 resources, 4.5 man hours of completed detailing work, over 1,200 medium to large projects delivered successfully, Vegazva is the right detailer for you.

**VIMAR Steel**

**booth 2029**  
 Houston  
**ph:** 979.250.7159  
[www.vimarsteel.com](http://www.vimarsteel.com)

Vimar Steel was born as the American branch of Vimar Group, from its success in steel distribution. Vimar Group has 35+ years in the market, always offering unsurpassed customer service and products of the highest quality that meet all international standards. Vimar Steel supports the U.S. market with a service center strategically located in North Houston. We can guarantee supply and total customer satisfaction throughout the U.S. Vimar Steel provides professional experience and technical knowledge to assist you throughout your project. Let our competitive prices and superior customer service support your business.

# exhibitor list :: NASCC: THE STEEL CONFERENCE

## Virtek Vision booth 1348

Waterloo, Ontario  
Canada

ph: 519.746.7190

[www.virtekvision.com](http://www.virtekvision.com)

Virtek Vision provides laser templating solutions for steel assembly. Visit with us to see how laser projection has increased efficiencies in the layout and assembly of steel products, including hand-rails, trusses, and stair stringers.



## VIRTUELE

booth 1455

[www.virtuele.us](http://www.virtuele.us)

## Voortman Steel Machinery

booth 125

Monee, Ill.

ph: 708.885.4900

[www.voortman.net](http://www.voortman.net)

Voortman Steel Machinery is the leading global manufacturer of highly automated steel processing machinery. From compact processing lines to large, fully automated systems with everything connected. Over 50 years of experience means that Voortman can offer solutions for every type of project. Voortman is continuously developing new machinery and software solutions to meet increasing industry demands. Voortman works with you to identify the best solution, tailoring systems to ensure you can exceed your processing goals.



## Voss Engineering, Inc.

booth 1517

Lincolnwood, Ill.

ph: 847.673.8900 | toll free: 800.323.3935

[www.vossengineering.com](http://www.vossengineering.com)

Voss Engineering, Inc. provides expansion/slide bearing assemblies, bearing pads, and isolation materials for highway bridges, industrial structures, machines, process piping, and commercial buildings. Voss' product line includes the following structural bearing pad materials: SORBTEx (preformed fabric pad/cotton duck pad/CDP), VSB Slide Bearings (PTFE and steel plate), VTB (thermal break pad), NEOSORB [AASHTO grade neoprene (polychloroprene)], and FIBERLAST or VOSSCO (random oriented fiber pads).

## WBF Steel Services, LLC

booth 2010

Sheridan, Wy.

ph: 248.301.0901

[wbfsteel.com](http://wbfsteel.com)

WBF Steel Services LLC, with 10+ years of experience, excels in delivering top-tier steel and PEMB detailing services for diverse projects. Our dedicated team specializes in 3D detailing, offering expertise in project management, BIM coordination, estimation, connection design, and engineering services. Leveraging cutting-edge technology, we use industry-leading software like Tekla and SDS2, seamlessly integrating with platforms such as Strumis, Tekla PowerFab, and BIM360. Our commitment to precision and innovation ensures solutions that meet the highest standards in the steel detailing landscape.

## Whiteboard Technologies LLC

booth 1623

Corcoran, Minn.

ph: 612.605.5833

[www.whiteboardtec.com](http://www.whiteboardtec.com)

For more than two decades, Whiteboard has perfected the delivery of professional steel detailing with an unwavering focus on quality and design-based thinking in all structural steel and PEMB projects. We invest organically in having the right people who understand steel fabrication and erection from a value perspective and deliver quality solutions to a diverse range of construction projects. Our hybrid-delivery model offers on-site and offshore to ensure that there is maximum utilization of our detailing teams round the clock. We use 3D BIM software such as SDS2 and Tekla to detail the steel projects ranging from 50–15,000 tons.

## Working Athlete

booth 1842

[www.workingathlete.com](http://www.workingathlete.com)

## Würth Construction Services

booth 1717

Birmingham, Ala.

ph: 800.336.3494

[www.wurthindustry.com/construction](http://www.wurthindustry.com/construction)

Würth Construction Services is your one-stop shop solution for the construction industry. We supply structural fasteners, tools, PPE and safety, sealants and chemicals, abrasives, pipe clamps and hangers, electrical products, and more.

## Wuxi Zhouxiang Laser Machinery Co., Ltd

booth 2027

Wuxi, Jiangsu

China

ph: 86.510.8879.4887

[www.wxzhouxiang.com](http://www.wxzhouxiang.com)

China Zhouxiang Group, established in 1991, covers an area of more than 100,000m<sup>2</sup>, fixed assets CNY200 million, with more than 400 staff, Zhouxiang is a high-tech enterprise which combines science and technology, industry production and trade into one. Our products mainly include H-beam welding line, CNC cutting machine, laser cutting machine, H-beam assembly machine, H-beam welding machine, H-beam straightening machine, shot blasting machine, Box beam production line, pipe fabrication equipment, welding positioner, edge milling machine, CNC drilling machine, plate rolling machine, etc.

## X SERIES USA

booth 642

[www.xseriesusa.com](http://www.xseriesusa.com)

## X-Steel Detailing

booth 1145

Elgin, Ill.

ph: 854.429.2520

[www.x-steeldetailing.com](http://www.x-steeldetailing.com)

X-Steel Detailing was founded in 2019. We specialize in structural (beams, columns, braces) and miscellaneous (stairs, railings) steel structures in several different industries. We use the latest technology to improve your experience, utilizing both SDS2 AND Tekla software to provide model files, BIM coordination capabilities, and electronic files (CNC, KSS) for your shop's needs. We focus on providing quality shop drawing packages within budget and on time. We strictly adhere to our client's standards and the AISC Code of Standard Practice and customize services as required to ensure a smooth project. ■

Color Key:

Bridge Pavilion Exhibitor

Heavy Machinery Area

Safety Pavilion Exhibitor

230+ sessions | 16 PDHs | 320+ exhibitors

**NASCC:  
THE STEEL  
CONFERENCE**  
MARCH 20–22, 2024

...and save the date for next year!

**NASCC:  
THE STEEL  
CONFERENCE**  
APRIL 2–4, 2025  
KENTUCKY INTERNATIONAL CONVENTION CENTER  
LOUISVILLE, KENTUCKY



# Ironworkers. The sky is the limit.



In the U.S. and Canada:  
4,000 Contractors  
157 Training Centers  
7,374 Certifications in 2023  
20,000 Apprentices and Trainees  
21,198 Certified Ironworker Welders  
\$90 million invested annually in training  
130,000 Ironworkers and billions in contracts  
for the most recognizable projects

## Ironworkers

SAFETY. QUALITY. PRODUCTIVITY.

[WWW.IRONWORKERS.ORG](http://WWW.IRONWORKERS.ORG) | [WWW.IMPACT-NET.ORG](http://WWW.IMPACT-NET.ORG)



Put your trust in safe and professional ironworkers.  
Don't bet your multimillion dollar projects on mediocre training.



## new products

This month's New Products features four recently released automated fabrication machines and a new driverless sideloader.



### Beamcut Systems BC25

Beamcut Systems' new BC25 is a user-friendly, versatile, robotic 3D CNC cell and platform for cutting metal parts and profiles for virtually any structural steel shape and metal type in the industry. Using high-definition plasma technology and FANUC robotics, the BC25 is a totally automated beam cutting system providing maximum optimization of the manufacturing process, which in turn improves overall repeatability and accuracy. It eliminates bothersome layout work before cutting and time-consuming and costly grinding after profiles are cut.

Manufacturers and steel fabricators can expect exceptional aftermarket support, along with a totally automated in-feed and out-feed system on a smaller footprint. They can also expect a totally automated beam cutting solution costs up to 20% less than competitive options, providing a quicker return on investment. For more information about the BC25, visit [www.beamcut.com](http://www.beamcut.com).

### Lincoln Electric Cooper Cobot Cart

Lincoln Electric has combined more than a century of welding knowledge and extensive automation experience with your real-world needs to create the Cooper Cart. It's the affordable, game-changing solution you need to level up your welding and your business. Its features include:

- The Cooper App: Makes it simple for anyone to program and create a quality weld. On screen instructions guide users step-by-step through the process of creating welds, and no training is required.
- The Power Wave® R450 Power Source: Welds with a FANUC® CRX robot driven by a Lincoln Electric Power Wave R450 power source. The Power Wave software controls and monitors welding processes delivering the highest levels of weld quality and productivity.
- Robotic Service and Support: Lincoln Electric offers free online training, in-person training classes, the support of 275 technical sales representatives, and the expertise of 115 robot technicians.
- Safety: Cooper welding cobots are designed for safe, direct human interaction.

For more information, visit:

[lincolnelectric.com/en/Products/Automation](http://lincolnelectric.com/en/Products/Automation).



### Voortman Fabricator

The construction industry is witnessing rapidly changing market requirements, causing several increasing challenges for structural steel fabricators. The most frequently heard challenge is the pressing need to deliver projects on schedule in combination with consistently decreasing availability of skilled fitters and welders.

This is where The Voortman Fabricator comes in, a groundbreaking automatic fitting and full-welding system for structural steel.

The Fabricator is the premier welding system for structural steel. Its flexibility lets users choose on the fly between Fit and Weld or only Fit. It offers the quickest turnarounds, maximum efficiency in space utilization and choice-based flexibility. All help make Voortman's ROI the fastest on the market.

The Fabricator can help:

- Ensure on-schedule project with reliable and flexible welding capacity.
- Access a flexible workhorse free from staffing constraints.
- Achieve consistent, high-quality welds and beat material tolerances.
- Secure the quickest return on investment in the market.

To learn more, visit [www.voortman.net/en/products/machinery](http://www.voortman.net/en/products/machinery).



## Combilift Combi-AGT

Combilift has launched its first autonomous vehicle, the four-wheel electric stand-on Combi-AGT sideloader.

Combi-AGT's design is based on the electric manually operated Combi-GTE model which has long been a very popular choice for service centers due to its ability to work efficiently in rail guided narrow aisles. The Combi-AGT harnesses the latest smart technology to meet customer demands for driverless sideloader capability. Those demands were driven in part by the desire to eliminate the presence of personnel in aisles, consistency in handling procedures, and to maximize order fulfillment, while also having a backup manual mode in case of power outages or internet disruptions.

The machine's laser-based sensors, fitted at various positions on the chassis, constitute an anti-collision safety system. If the machine senses an obstacle or pedestrian that has entered its path, it automatically slows down and stops in cases of emergency. It will resume driving automatically when the obstacle has cleared its safety sensor area.

Combi-AGT's natural feature navigation system is superior to traditional methods of truck navigation based on wire guidance or artificial landmarks such as reflectors. Instead, it uses the naturally occurring features in a warehouse, such as walls, racking, and columns. Its newly developed load dimension detection system operates by performing a laser scan of the load to check that its length matches the task sent to the machine. Similarly, when unloading, it checks that the rack in front has sufficient free space to accept the load. To learn more, visit <https://combilift.com/combi-agt/>.

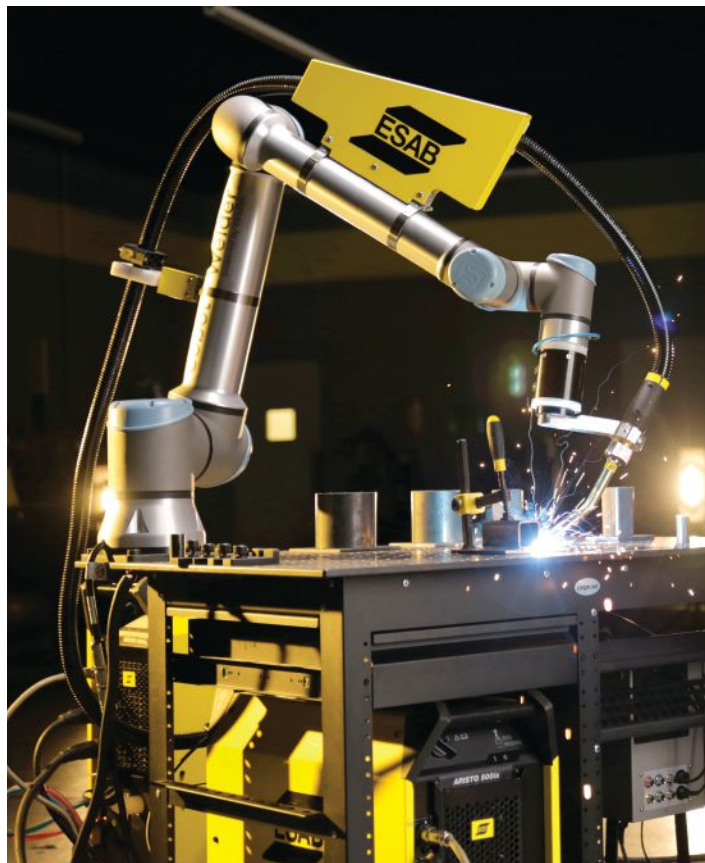
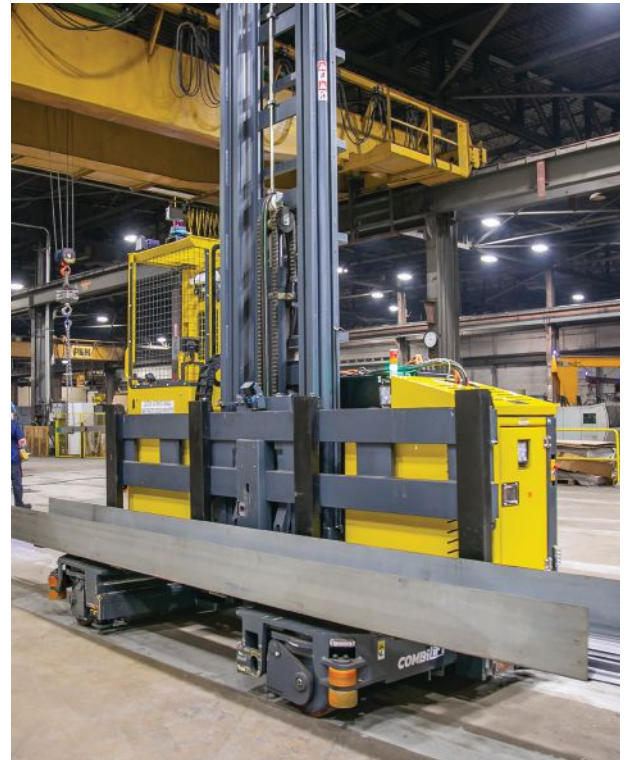

## ESAB Cobot

ESAB has introduced its first cobot, or collaborative robot, for MIG and pulsed MIG welding applications on steel, stainless steel, and aluminum alloys. Unlike the complex programming pendants of other cobots, the ESAB Cobot enables operators to teach welding paths using a software app that runs on a standard smart phone or tablet (Apple iOS or Android) and a "Smart Puck" to hand-guide the torch and record its position with the push of a button.

Creating a weld sequence is as simple as creating a song playlist. The ESAB Cobot costs a fraction of a pre-engineered robot cell, does not require a programmer, and deploys in a matter of hours. It features a Universal Robots UR10e industrial robot arm. UR is the automation industry's leading provider of cobots and has an installed base of more than 50,000 cobots. Welding components include ESAB's premiere heavy industrial welding system, the Aristo® 500ix pulse power source, the RobustFeed U82 wire feeder, an air- or water-cooled torch and accessories.

A Siegmund 32-in. by 48-in. welding table organizes components and enables the cobot to move around a shop. The entire package ships on a pallet typically within two to three weeks of ordering from a distributor. Set up takes a few hours following step-by-step instructions accessed with a QR code. If a user has the skills to set-up an industrial MIG system, they have the skills to start automated welding with the ESAB Cobot. For more information, visit [www.esab.com/us/nam\\_en/products-solutions/](http://www.esab.com/us/nam_en/products-solutions/).

## STANDARDS

### Revised AISC Standard Available for Public Review

A draft of the next edition of the AISC *Specification for Safety-Related Steel Structures for Nuclear Facilities* (AISC N690) is available for public review until March 18, 2024. This is a planned revision to the 2018 edition of

the standard. To access the draft and the review form, visit [aisc.org/publicreview](https://aisc.org/publicreview). You can also order a hard copy—for a \$35 nominal charge—by contacting Martin Downs at [downs@aisc.org](mailto:downs@aisc.org). Please submit

comments using the forms provided at the website above to Nathaniel Gonner at [gonner@aisc.org](mailto:gonner@aisc.org) by March 18, 2024.

## SSSBA

### States Make Strides in Infrastructure Development



In November 2021, Congress passed the Infrastructure Investment and Jobs Act, which is now the Bipartisan Infrastructure Law. This legislation addressed the need to upgrade infrastructure that was overdue for improvement.

The Bipartisan Infrastructure Law was intended to:

- Rebuild America’s roads, bridges and rails
- Expand access to clean drinking water
- Ensure every American has access to high-speed internet
- Advance environmental justice
- Invest in communities too often left behind.

The Short Span Steel Bridge Alliance (SSSBA) continues to identify examples of states across the U.S. taking advantage of this funding opportunity to update their aging infrastructure.

There have been many recent examples of innovative bridge construction projects across the U.S., including Barron County’s installation of Wisconsin’s first steel press-brake-formed tub girder bridge.

Elsewhere, New York State Gov. Kathy Hochul recently announced that more than 2,800 bridges were replaced or

improved in 2023. These projects invested more than \$2.4 billion into New York’s roads and bridges and reflect the governor’s commitment to improving New York’s infrastructure. The New York State Department of Transportation replaced or improved 2,833 bridges statewide, a nearly \$1.7 billion investment.

Hochul wants to enhance safety and sustainability, reconnect communities, promote growth, and enhance resiliency against climate change.

“During this construction season, we put the pedal to the metal on our record-setting efforts to modernize New York’s transportation network and improve travel all across the state,” Hochul said. “These paving and bridge projects will provide motorists in every corner of this state with a smoother ride while also helping to ensure that our transportation network can be among the most resilient and sustainable in the nation.”

As bridge owners and designers consider the numerous infrastructure-related projects that will be funded through the Bipartisan Infrastructure Law, they should ask themselves if steel is the right material to them to specify.

Bridge officials who take a holistic approach to design that includes economy, sustainability, resiliency, and durability know that steel provides a viable solution for these projects.

Steel solutions provide:

- Cost savings that can be significant: smaller abutments, use of local crews, fast installation, lighter equipment—when added up, steel provides significant cost savings.
- A durable and nonporous material, steel provides value and a significant return on investment with bridges that last more than 100 years and have minimal maintenance requirements during their service lives.
- Steel’s high strength permits longer spans, minimizing disruption to underlying habitats. In some cases, this can eliminate the need to undertake costly environmental impact studies.
- Steel from a disassembled bridge can be used again for another project. Steel is the most recycled material on the planet and can be recycled continuously without losing its strength.



IN MEMORIAM

Renowned Iowa State University Engineering Professor Wallace Sanders Dies At 90

Renowned engineering professor and researcher Wallace Sanders, PhD, died January 6. He was 90.

Sanders taught in the Iowa State University Department of Civil, Construction and Environmental Engineering for 34 years until his retirement in 1998. He was a passionate advocate for engineering education, with an emphasis on steel bridge design. He had many roles during his Iowa State tenure: professor; associate professor; assistant and associate director of the Engineering Research Institute for 11 years; associate dean of the College of Engineering for three years; director of the Iowa Space Grant Consortium for four years; and interim assistant vice provost for research and graduate students.

“Professor Sanders lived a remarkable life,” said W. Samuel (Sam) Easterling, PE, PhD, Iowa State’s Dean of Engineering. “He served Iowa State for nearly 40 years, contributing significantly to the Civil, Construction and Environmental Engineering department; the College of Engineering; and the university. He likewise made major contributions to our profession. We will deeply miss his positive attitude, engaging smile, and friendship.”

Sanders’ research focused on the behavior and design of highway and railway bridges; aluminum structures; and developing design specifications for structures. He served on many professional and technical committees, including several within AISC. He was on the *Engineering Journal* review board, the Partners In Education Committee, and the AISC Fellowship Award Jury.

In 2013, Sanders earned an AISC Lifetime Achievement Award for Excellence in Engineering Education. In addition, the American Society of Civil Engineers (ASCE) awarded him its Reese Research Prize and named him a fellow.

Sanders also was on committees within ASCE, the American Society for Engineering Education, the American Welding Society, the American Railway Engineering and Maintenance of Way Association (AREMA), the European Committee for Constructional Steelworks, and the Transportation Research Board.

“Wallace was the beloved secretary of AREMA Committee 15, Steel Bridges for over two decades, said Ronnie Medlock, High Steel Structures Vice President of Technical Services. “He imbued the committee with camaraderie, candor, and sincerity, setting an enjoyable yet imperative vitality that helped the members drive toward the best practices in steel railroad bridge design and construction. Eschewing ties and titles, Wallace kept things salient yet simple and fun. He was so liked and respected that when he stepped down as Secretary, Committee 15 established an AREMA structural engineering scholarship in his name.

“Wallace was famous for saying, ‘If you were late to the curb for the meeting field trip, you’ll get to see the back of the bus.’ How poignant, because we members all knew who was really driving the committee bus, and if Wallace was driving, you wanted to be on it.”

Iowa State still felt Sanders’ presence and impact after his retirement. In 2006, the university opened the Wallace W. and Julia B. Sanders Structural Laboratory, which houses an 80-ft by 24-ft reaction floor equipped with 300,000-lb capacity loading points on a 3-ft grid and a 15-ton overhead crane.

Sanders is survived by his daughter, Linda Sanders, and son, David (Tina) Sanders; brother John (Carole) Sanders; two grandchildren, and three great-grandchildren. He was preceded in death by his wife, Julia; his parents; and his foster brother, Stephen Nettles.



People & Companies

KAI promoted **Aleksandar Milenkov, PE** to Engineering Design Principal at its Dallas-Fort Worth office. Milenkov joined KAI in 2020 as Director of Mechanical Engineering.

In his new position, Milenkov will provide overall practice leadership for KAI’s Engineering business. His primary focus will be resource management; talent growth, retention and development; technical standards and quality; and budget and schedule execution for engineering projects. Additionally, Milenkov will drive engineering best practices, fostering an environment of collaboration within a multi-discipline team environment.

**Walter P Moore** promoted **Kelly Roberts** to the role of Managing Director of the Atlanta Structural Engineering team.

In addition to her role as a principal, Roberts is a distinguished leader in structural design, with an extensive portfolio encompassing diverse projects including educational and healthcare facilities to commercial and healthcare structures. As the head of the firm’s Sustainable Design Community of Practice within the structures group, Roberts specializes in life cycle assessment, embodied carbon studies, and the integration of sustainable and salvaged materials.

Roberts’ dedication and expertise have earned her numerous accolades, including being named among *Engineering Georgia’s* Top 100 Influential Women in 2023, 2022, and 2021 and being honored as part of *Building Design+Construction’s* 2021 40 Under 40 Class.

**NASCC**

**Registration for NASCC Remains Open**

NASCC: The Steel Conference is heading to San Antonio, Texas, March 20–22.

There’s still time to register for the industry’s top education event, featuring more than 230 technical sessions full of must-have practical information that you can implement as soon as you get home, an exhibit hall packed with 280-plus innovations you need to know about right now, and a chance to network with thousands of the world’s best designers, fabricators, erectors, and other steel fans.

The Steel Conference is the must-attend educational event of the year and

focuses on providing actionable information you can put into practice right away while earning up to 16 PDHs.

The Steel Conference also incorporates six specialty conferences: the World Steel Bridge Symposium, QualityCon, Architecture in Steel, SafetyCon, SEICon24, the SSRC Annual Stability Conference, and the NISD Conference on Steel Detailing. For more details on The Steel Conference and these specialty conferences—and to register—visit [aisc.org/nascc](http://aisc.org/nascc).

**FHWA**

**FHWA Seeks Bridge Grant Applications**

The Federal Highway Administration issued a notice of funding opportunity for the competitive Bridge Investment Program established by President Biden’s Bipartisan Infrastructure Law, which includes the single largest dedicated investment in bridges since the construction of the Interstate highway system.

The notice of funding is for up to \$9.6 billion in fiscal year 2023 through 2026 bridge project grants and \$80 million in 2023 through 2026 bridge planning project grants. This competitive grant program comes on top of more than \$27 billion in formula bridge funding the U.S. Department of Transportation announced in 2022.

“With [this] funding, communities can plan and implement bridge projects that will improve safety and mobility for people in rural regions, urban areas, and places in between,” FHWA Administrator Shailen Bhatt said in a statement. “The Bridge Investment Program has already funded nearly 40 bridge projects nationwide, and this funding will help communities continue to plan and advance important bridge projects in the years ahead.”

The Bridge Investment Program notice of funding opportunity is

soliciting applications for the following categories of projects:

- Planning: grants for planning, feasibility analyses, and revenue forecasting associated with the development of a project
- Bridge Project: grants for bridge replacement, rehabilitation, preservation, and protection projects with total eligible costs of \$100 million or less.

Both grants will cover a maximum of 80 percent of the total eligible project costs.

The deadline for fiscal year 2023 and 2024 bridge project applications is March 19. (The deadline for 2023 and 2024 planning applications was February 19). The deadline for bridge project applications for 2025 is November 1, and the deadline for 2026 applications is November 1, 2025.

Applications for fiscal year 2024 planning grants are due October 1, and 2026 planning grant applications are due October 1, 2025.

FHWA will be providing education opportunities and plans to conduct outreach regarding the Bridge Investment Program planning and bridge project grants via webinars, with technical assistance also available to recipients who receive grants.

A.C.T. Metal Deck Supply	37
Akyapak	22
Applied Bolting	73
Autodesk	54
Automated Layout Technology	69
Beamcut/Machitech	29
Birmingham Fastener	50
Bull Moose Tube	65
Canam Group	5
Canam Steel Corporation	79
Chicago Metal Rolled Products	insert
Controlled Automation	43
Delta Steel/Infra-Metals	11
Ficep	21
Fontana Fasteners	73
IMPACT	83
InfoSight	20
Integrated Engineering Software	8
MDX	37
Mold-Tek	14
New Millennium	15
Peddinghaus	2
Prodevco	65
QuickFrames	29
SDS2/Allplan	7
Sherwin-Williams	back cover
Smith-Emery	13
St. Louis Screw and Bolt	79
Trimble	91
Voortman	19





## SMITH-EMERY

Inspection • Testing • Metallurgy

Assuring Structure & Life Safety Since 1904

### Non-Destructive Testing

- PAUT
- Visual (CWI, CWB, CSWIP)
- MT
- UT

### Owner QA

- Fabrication Oversight
- Specification Review
- Field Inspections
- WPS Reviews

**Metallurgical Laboratory**  
**Environmental Laboratory**  
**Firestop Inspection**

### Supplier Audits

- IAS
- IAPMO
- City of Los Angeles
- Clark County, NV

### Contractor QC

- Fabrication Shop NDT, CWI
- Vendor Audits
- QMS Development
- WPS and PQR Testing

**Curtain Wall Performance Testing**  
**Concrete Testing**  
**Chemical Laboratory**

1.833.405.0536

steel@smithemery.com

www.smithemery.com



## STEELFAB

We are a third-generation family-owned company and one of the largest and most experienced steel fabricators in the United States. Evolving from a local business in Charlotte, NC into a national brand, our team is committed to outstanding customer service and on-time delivery of a superior product.

We are currently hiring for an experienced Project Manager in our Raleigh office!

Visit our job posting at the web address below or by scanning the QR code.

<https://www.steelfab-inc.com/careers/assistant-project-manager-raleigh/>



## marketplace & employment

### sCheck: A Powerful Steel Analysis and Design Tool

sCheck is a simple yet powerful Windows tool to analyze and design steel shapes according to AISC 360-16 (15th edition) LRFD, AISC 360-10 (14th edition) LRFD, and AISC 360-22 (16th edition) LRFD.

Key Features:

- **Shape Compatibility:** sCheck assesses the capacity of various AISC shapes: W, M, S, HP, C, MC, L, WT, MT, ST, 2L, HSS, Pipe.
- **Optimal Design:** It selects the best AISC shapes for your project based on load effects.
- **Moment Magnification:** It can account for moment magnification in non-sway conditions.
- **Professional Documentation:** It generates incredibly detailed calculation procedures in Microsoft Word and PDF formats.

Visit [www.cg-inc.com](http://www.cg-inc.com) to download a free evaluation version.



## LATE MODEL STRUCTURAL STEEL MACHINES AVAILABLE IMMEDIATELY

**PEDDINGHAUS OCEAN AVENGER PLUS 1250/1C**, 8-ATC, 3000 RPM, 40" Table, Siemens 840D, 2019, #32543

**PEDDINGHAUS HSFDB 2500/B** Plate Processor, HPR260XD Plasma, Drill & Oxy, 2014, #42977

**PEDDINGHAUS PCD1100/3B**, 40" Beam Drill, Siemens CNC, In & Out Feed Conveyor, 2016, #43033

**PEDDINGHAUS (MEBA) 1250-510** Straight Cut, 49" x 20" Cap., 20 HP, Re-Manufactured By Peddinghaus 2015, #32852

**PEDDINGHAUS AFPS 643Q** 6" x 6" x 5/8" Anglemaster, 230 Ton Single Cut Shear, Conveyor, 2011, #42975

**PEDDINGHAUS PEDIWRITER PW-1250**, (2) Hypertherm ArcWriter Torches, Siemens CNC, 2015, #32576

**PYTHONX** Robotic Plasma Cutting System, HPR260XD Plasma, Conveyor & Transfers, 2014, #32963

**CONTROLLED AUTOMATION DRL-348TC** Drill, 3-Spindle, ATC, Hem Saw, Conveyor & Transfers, 2009, #32361



SCAN QR CODE TO VIEW OUR LATEST INVENTORY

**CALL US REGARDING YOUR SURPLUS EQUIPMENT, INDIVIDUAL ITEMS OR COMPLETE PLANTS**

Contact: [Claire@PrestigeEquipment.com](mailto:Claire@PrestigeEquipment.com)

[www.PrestigeEquipment.com](http://www.PrestigeEquipment.com) | (631) 249-5566

## Connect with AISC on SOCIAL MEDIA



[aisc.org/linkedin](https://www.linkedin.com/company/aisc)



@AISC



AISCdotORG



@AISC



[youtube.com/AISCSteelTV](https://www.youtube.com/AISCSteelTV)

## Structural Engineers

Are you looking for a new and exciting opportunity?

We are a niche recruiter that specializes in matching great structural engineers with unique opportunities that will help you utilize your talents and achieve your goals.

- We are structural engineers by background and enjoy helping other structural engineers find their "Dream Jobs."
- We have over 30 years of experience working with structural engineers.
- We will save you time in your job search and provide additional information and help during the process of finding a new job.
- For Current Openings: visit our website, select Hot Jobs.
- Please call or email Brian Quinn, PE: 616.546.9420  
**Brian.Quinn@FindYourEngineer.com**  
so we can learn more about your goals and interests.  
*All inquiries are kept confidential.*

SE Impact by SE Solutions, LLC | [www.FindYourEngineer.com](http://www.FindYourEngineer.com)



## Readying for Regionals

**ASPIRING BRIDGE DESIGNERS** are gearing up for competition.

Student engineers at over 200 colleges and universities across the United States and Canada are designing, fabricating, and assembling the scale river crossings they hope will bring them victory in this year's Student Steel Bridge Competition (SSBC), a collaboration between AISC and the American Society of Civil Engineers.

These SSBC teams will put their skills and bridges to the test at 20 regional competitions this spring, with finalists advancing to the national finals at Louisiana Tech University May 31 through June 1. Regional competitions begin March 7–9

with the Gulf Coast, hosted by the University of New Orleans. The last one is the Northeast regional, held April 19–21 at the University of New Hampshire. The University of Florida's team won the 2023 competition, its third straight title.

For more than 35 years, aspiring engineers have applied skills learned in classes to designing a scale steel bridge—assembled in a timed environment and load-tested with 2,500 lb. The bridge must span about 20 ft, and it's also judged on aesthetics. Many SSBC alumni have called the event the highlight of their college careers, leading to professional opportunities, lasting friendships, and an incredible sense of accomplishment.

Non-students can experience the contest too.

AISC and ASCE are looking for volunteers to help the schools hosting events provide an awesome in-person experience for these students. Volunteers do not need to be bridge engineers. They're needed for setup, event judging (preceded by training), and other crucial tasks such as helping with the registration desk and distributing lunch that make the regional competitions and finals run smoothly. Previous SSBC experience is not required.

Anyone interested in helping must complete the volunteer interest form found at [aisc.org/ssbcvolunteers](https://aisc.org/ssbcvolunteers). ■



# It's a New Era in Steel Detailing

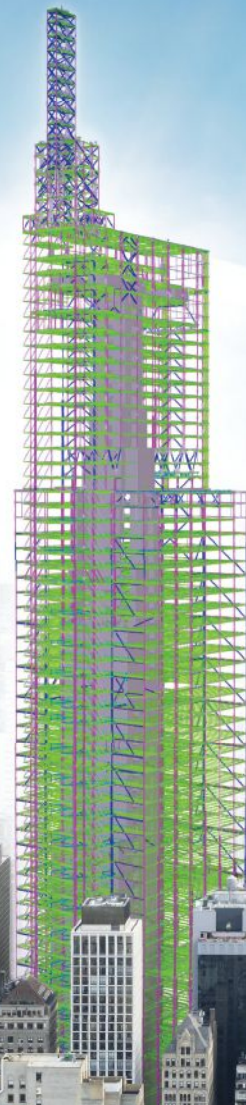

## Don't Get Left Behind

If your detailing software is limiting your ability to transition to more efficient workflows, then we have good news to share—with our new flexible subscription offering, there has never been a better time to switch to Tekla Structures, the industry's leading 3D, truly constructible, steel detailing software.

If you are ready to learn how using Tekla Structures can enable more efficient workflows leading to improved financial outcomes, visit [tek.la/new-era](https://tek.la/new-era) and request a demo.

# ENGINEERING-BASED FIRE DESIGN

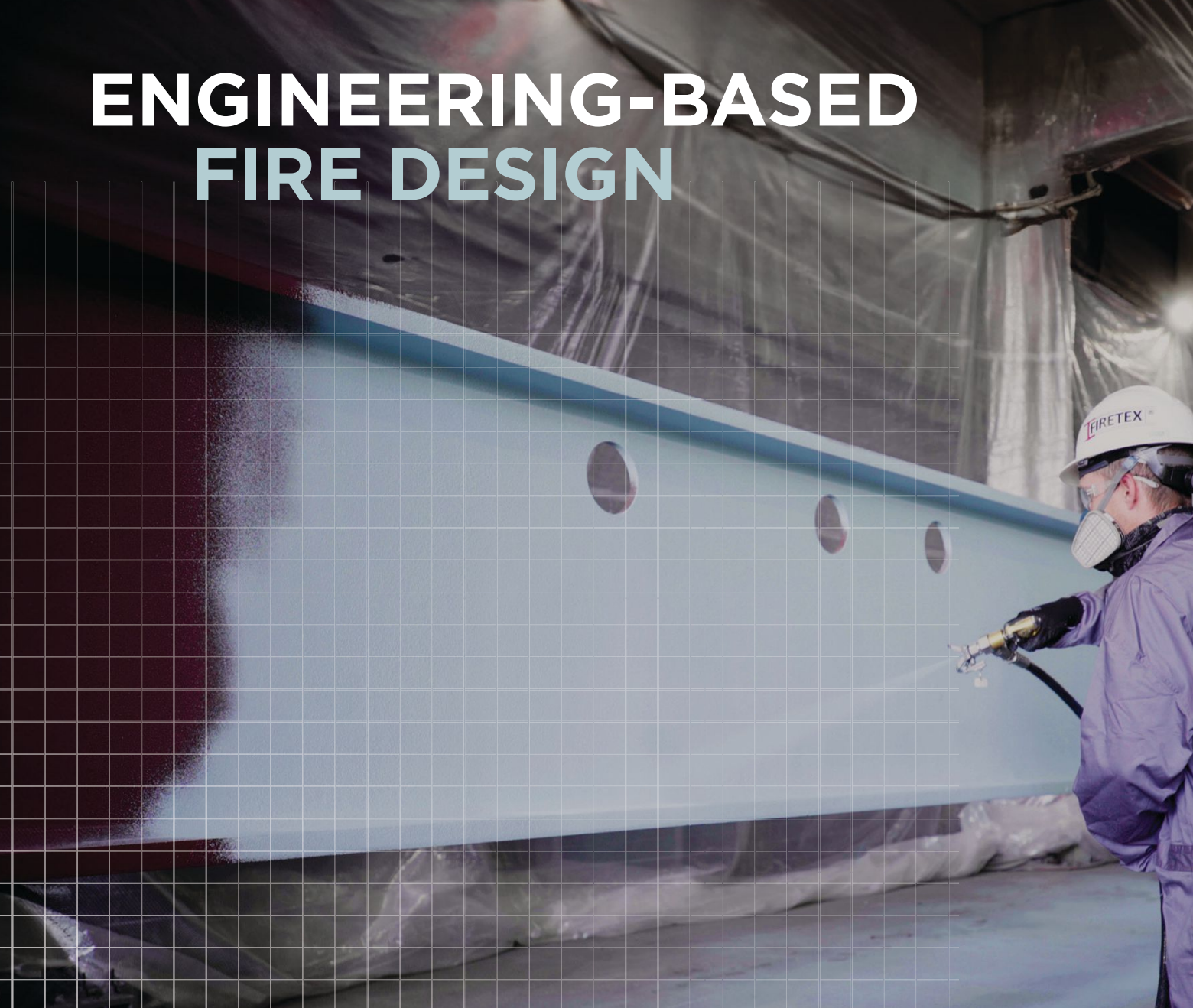

Achieve peak steel fire protection by collaborating with our dedicated team of fire protection experts. Our specialists utilize cutting-edge, in-house fire engineering design software, empowering structural engineers and designers to balance steel sizing and IFRM thickness for efficient, cost-conscious solutions.

**Contact your local fire protection expert today!**



Scan QR Code

**FROM SPEC TO PROTECT**

protective.sherwin.com  
swprotective@sherwin.com

**SHERWIN-WILLIAMS®**

© 2024 The Sherwin-Williams Company