

Steel Interchange

Steel Interchange is an open forum for *Modern Steel Construction* readers to exchange useful and practical professional ideas and information on all phases of steel building and bridge construction. Opinions and suggestions are welcome on any subject covered in this magazine. If you have a question or problem that your fellow readers might help to solve, please forward it to *Modern Steel Construction*. At the same time feel free to respond to any of the questions that you have read here. Please send them to:

Steel Interchange
Modern Steel Construction
 1 East Wacker Dr.
 Suite 3100
 Chicago, IL 60601

Answers and/or questions should be typewritten and double spaced. Submittals that have been prepared by word-processing are appreciated on computer diskette (either as a Wordperfect file or in ASCII format).

The opinions expressed in *Steel Interchange* do not necessarily represent an official position of the American Institute of Steel Construction, Inc. and have not been reviewed. It is recognized that the design of structures is within the scope and expertise of a competent licensed structural engineer, architect or other licensed professional for the application of principles to a particular structure.

Information on ordering AISC publications mentioned in this article can be obtained by calling AISC at 312/670-2400 ext. 433.

The following responses to questions from previous Steel Interchange columns have been received:

Can you show a design of a bracket connection carrying moment (February 1993)?

One solution can be arrived at by visualizing that the beam and bracket act together as a single unit. The problem now is similar to a haunched beam-to-column connection which is a more familiar moment type connection. In order to design a rigid connection using the above assumption, an end plate can be utilized to which both the beam and bracket are fully welded. For the same reason, it is advantageous to weld the bottom flange of the beam to the top plate of the bracket rather than bolting them. This sub-assembly can be fabricated in a shop with relative ease and efficiency. It can then be bolted the column in the field later.

The vertical web stiffener, defining the critical area of the web, will create a web panel with an aspect ratio between 0.75 and 1.50. This web panel should be able to resist moment M_o without excessive shear deformation (no yielding or buckling). Otherwise, additional diagonal stiffeners will be required to carry the balance of flange tensile/compressive force via truss action.

The bracket shall be designed for vertical forces, V_m and V_o , applied at point A (Case I). The end plate should be proportioned to resist the same load, i.e. $V_m + V_o$, in tension. However, prying of the column connection bolts may control the end plate thickness requirement. In situations where the connection between the bottom flange of the beam and the bracket top plate is rendered through bolts in bearing, the end plate shall provide resistance against a portion of the shear force acting between the two surfaces. This is in addition to the tensile forces mentioned earlier and tends to complicate the end plate design.

The column connection bolts shall resist the fixed-end moment of the beam, M_f , and its end shear, V_f , for the clear span between columns. Column flange stiff-

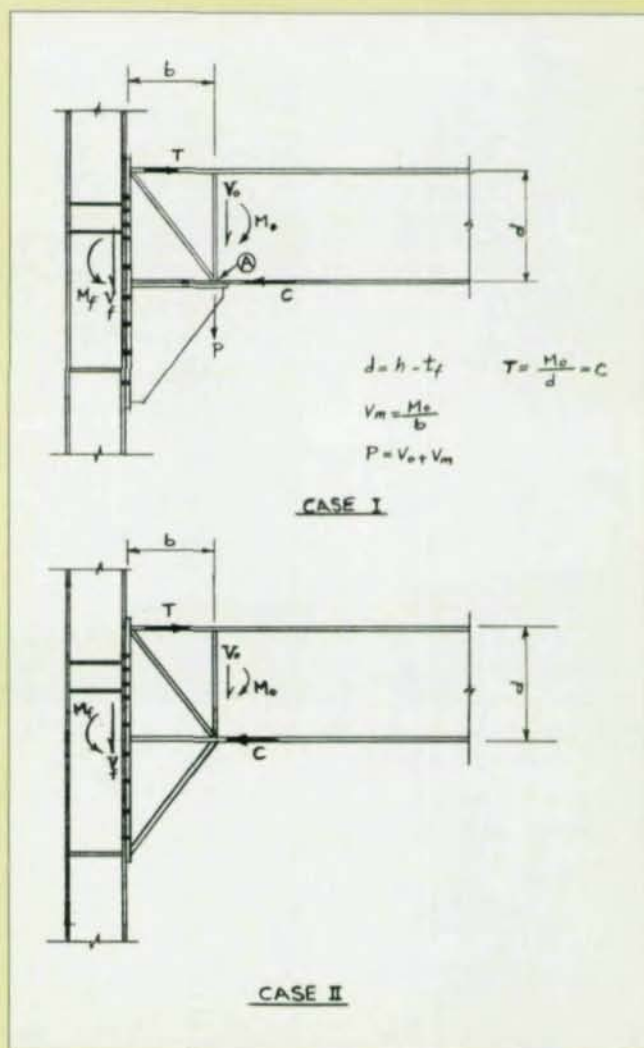

eners shall be provided similar to any other bolted connections.

If the flange area of the gusset plate is within the same order of magnitude of the beam flange area, it is preferable to use the same width for both flanges and eliminate the bracket top plate (Case II).

Abbas Pourbohloul
 Consolidated Rail Corporation
 Philadelphia, PA

Steel Interchange

Is it permissible to weld nuts to bolts to prevent them from backing off? Are any special welding procedures required? Is bolt or nut strength affected?

While it is not considered desirable to weld a nut to a bolt, it is not uncommon to encounter situations where loosening of nut could pose a real threat for structural failure. In a recent case involving

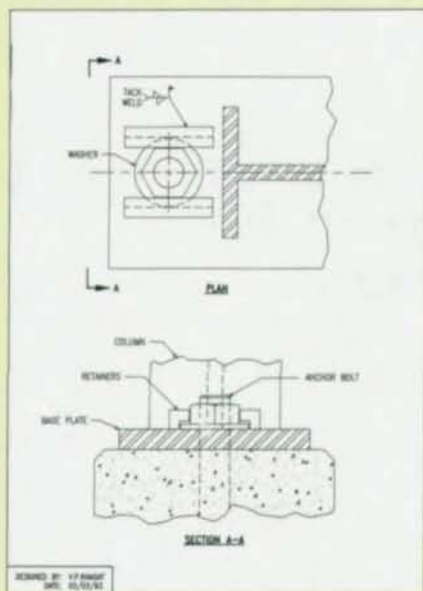

the base of a tall tower, the undersigned was faced with a similar situation where the columns were subjected to mild but continuous vibrations and loosening of the nuts had to be prevented. This was accomplished by tack welding retainer bars to the column base plate adjacent to each of

the two anchor bolts as shown in the figure. This was done because the anchor bolts did not have sufficient projection for a second (locking) nut.

Vijay P. Khasat, P.E.
Ohio Edison
Akron, OH

How can you connect wide-flange beams to tube columns?

The figure below shows a different concept of connecting wide-flange beams to all four faces of a structural tube column to transfer moment and shear than has previously been offered in *Steel Interchange*. The end stiffener plates, connection plates and other connection material can be shop welded and the beam can then be bolted to the column in the field.

George Chiang, P.E.
The Port Authority of NY and NJ
New York

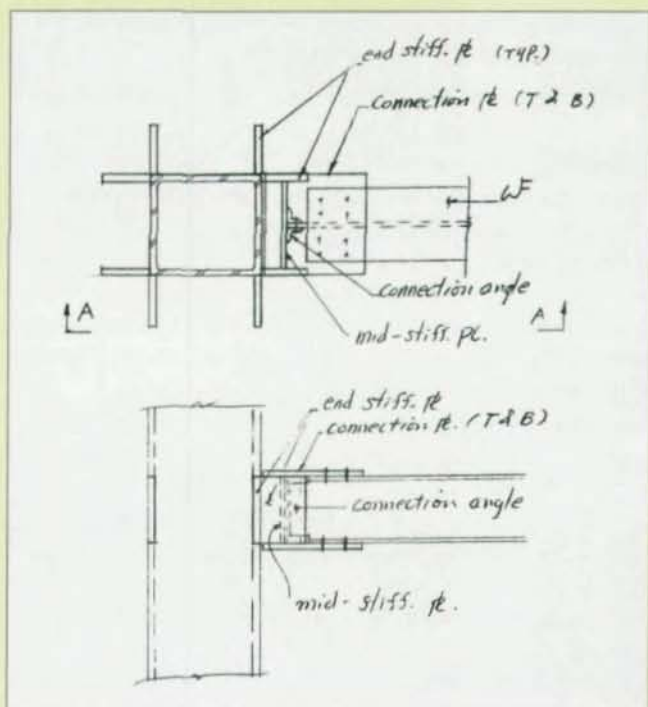

New Questions

Listed at right are questions that we would like the readers to answer or discuss.

If you have an answer or suggestion please send it to the Steel Interchange Editor, Modern Steel Construction, One East Wacker Dr., Suite 3100, Chicago, IL 60601-2001.

Questions and responses will be printed in future editions of Steel Interchange. Also, if you have a question or problem that readers might help solve, send these to the Steel Interchange Editor.

Under what circumstances does the designer have to consider torsion in the design of a beam?

Are there any design aids that will help an engineer design a steel arch or a communications tower?

How can one take into account blast effects in the design of steel structures?