

DESIGNING WITH  
**STRUCTURAL**

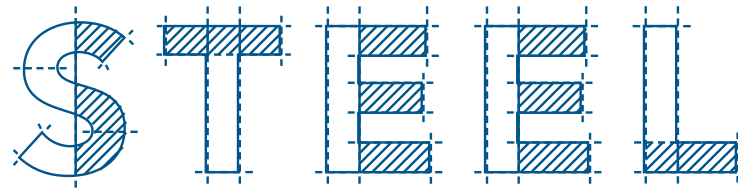

A GUIDE FOR ARCHITECTS

This guide is meant to inspire while providing practical information about structural steel, but there is so much more out there.

You can find further information, design guides, and references on our website at [aisc.org/architectsguide](https://aisc.org/architectsguide).

© AISC 2023

by

American Institute of Steel Construction

*All rights reserved. This book or any part thereof must not be reproduced  
in any form without the written permission of the publisher.  
The AISC logo is a registered trademark of AISC.*

The information presented in this publication has been prepared following recognized principles of design and construction. While it is believed to be accurate, this information should not be used or relied upon for any specific application without competent professional examination and verification of its accuracy, suitability and applicability by a licensed engineer or architect. The publication of this information is not a representation or warranty on the part of the American Institute of Steel Construction, its officers, agents, employees or committee members, or of any other person named herein, that this information is suitable for any general or particular use, or of freedom from infringement of any patent or patents. All representations or warranties, express or implied, other than as stated above, are specifically disclaimed. Anyone making use of the information presented in this publication assumes all liability arising from such use.

Caution must be exercised when relying upon standards and guidelines developed by other bodies and incorporated by reference herein since such material may be modified or amended from time to time subsequent to the printing of this edition. The American Institute of Steel Construction bears no responsibility for such material other than to refer to it and incorporate it by reference at the time of the initial publication of this edition.

Printed in the United States of America

You have a vision.

You want to bring it to life  
using materials that  
don't limit your creativity.

You want it to be sustainable.

You want it to be safe.





The American Institute of Steel Construction gives architects the tools they need to build a beautiful future in structural steel, taking full advantage of the many attributes that make steel the ideal structural material.

---

This booklet is divided into seven sections.

- 1** **Why Steel** will introduce you to the benefits that structural steel, and only structural steel, can bring to any building project.
- 2** **Engineering Basics** will show you how to create a structural layout for a building, with particular information about bay sizes, column sizes, and overall floor framing depths.
- 3** **Finishes, Coatings, and Fire Protection** provides critical information about various coating systems for structural steel and how each can be used to best fit the needs of your project.
- 4** **Sound Isolation and Noise Control** showcases how structural steel assemblies can be used to achieve Sound Transmission Class (STC) and Impact Isolation Class (IIC) ratings.
- 5** **Sustainability and Resilience** highlights structural steel's ability to provide a sound, resilient structure that's environmentally friendly. All structural steel produced in the U.S. is made of recycled steel and the end product is 100% recyclable.
- 6** **Detailing Considerations** demonstrates how to use structural steel in combination with other building materials such as precast concrete panels, masonry, thin stone veneer panels, and limestone.
- 7** **Architecturally Exposed Structural Steel** illustrates steel's ability to express the structural integrity of a building in a striking way while showcasing the true beauty of the structural system. The broad range of steel shapes and finishes provide infinite possibilities in terms of creative expression.

2017 IDEAS<sup>2</sup> National Award  
Los Angeles Valley College Monarch Center  
Valley Glen, Calif.  
Photo: Costea Photography Inc.





# Why Steel?

SECTION



steel is  
**ADAPTABLE**





2019 IDEAS<sup>2</sup> Presidential Award of Excellence  
75 Rockefeller Plaza, New York  
Photo: Gilsanz Murray Steficek

steel is  
**SUSTAINABLE**





2019 IDEAS<sup>2</sup> National Award  
Spectrum IV, San Diego  
Photo: Costea Photography Inc.

steel is  
**RESILIENT**







steel is  
**CAPABLE OF  
LONG SPANS**







2019 IDEAS<sup>2</sup> National Award  
UT Austin Engineering Education and Research  
Building Atrium, Austin, Texas  
Photo: Aislinn Weidele



steel has  
**HIGH RECYCLED  
CONTENT**





steel creates  
**COLUMN-FREE SPACES**





2019 IDEAS<sup>2</sup> Merit Award  
Apple Michigan Avenue, Chicago  
Photo: Nigel Young Foster + Partners



$$\left(-\frac{1}{3}\right)^{-10}$$

$$\cdot \left(\frac{1}{25}\right)^2 = 3^4 \cdot \left(\frac{3}{25}\right)$$

$$\neq 1^2 = 3 \cdot 2 = 6$$

$$\frac{24^4 \cdot 6^3 \cdot 12^2}{8^3 \cdot 3^4 \cdot 18} = \frac{24 \cdot 6 \cdot 15}{8^3 \cdot 6^3 \cdot 24 \cdot 6}$$

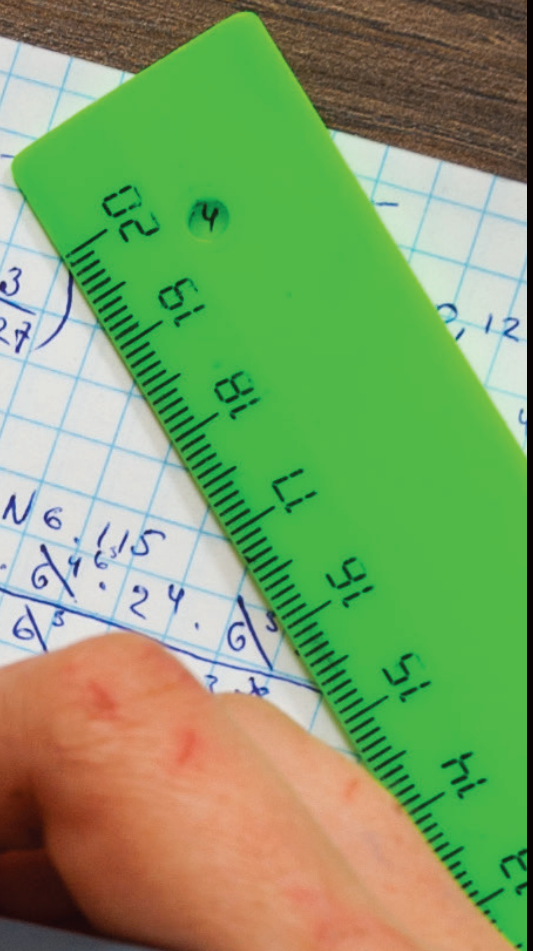
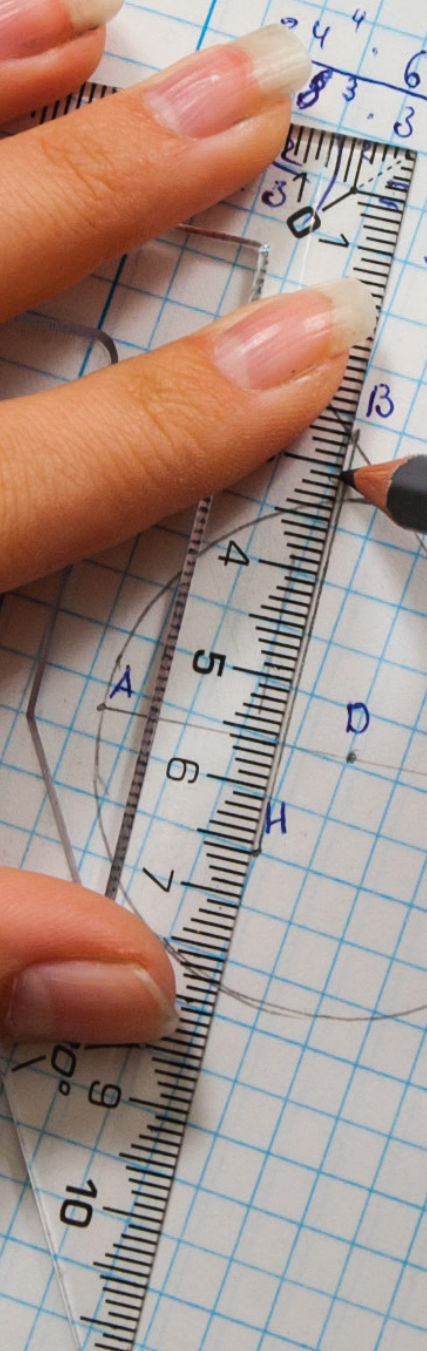



# Engineering Basics

.....

**SECTION**

**2**

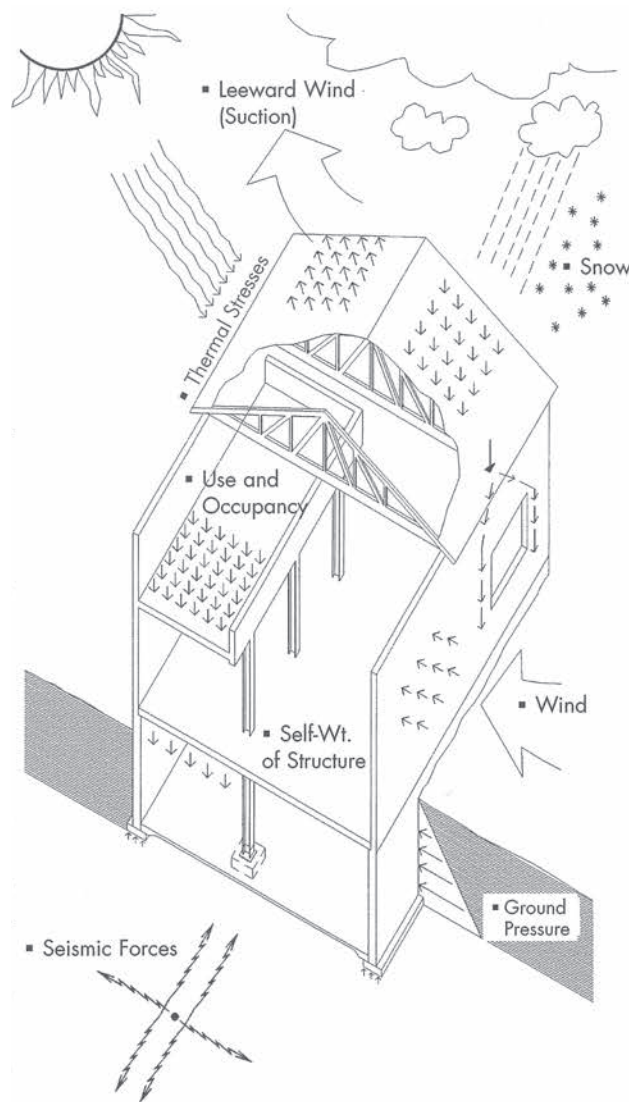

Fig. 1. Forces experienced by structures.

## You know that architecture and engineering go hand-in-hand.

The next few pages will provide information about the process of designing with structural steel. Ultimately, of course, your engineering specialists and other consultants will join the team, but these resources should help you begin the process of selecting preliminary structural systems and member depths.

## Understanding Load Flow

All structures are subjected to natural forces, such as wind, gravity, and seismic events. The question is, which natural forces will affect a building, and to what extent? The structural engineer will use that information to choose members that have the right strength and serviceability characteristics to plan how the structure will transfer each type of load to the ground.

## Gravity Loads

Engineers consider two different types of forces that are related to gravity.

“Dead” loads comprise the weight of the structure itself as well as things like mechanical equipment, ceiling and floor finishes, cladding, façades, and parapets. The dead load is essentially the amount of consistent weight that a building must support at all times.

“Live” loads account for things that are more transient in nature, like the weight of people moving around in the building, snow atop the structure or interior furnishings.

The floor decking and roof sheathing distribute the load to uniformly spaced beams. Girders span from column to column and support the ends of those beams. Those girders may end up supporting other girders, as well, before transferring the force to structural columns which then carry the vertical load to the foundation elements below.

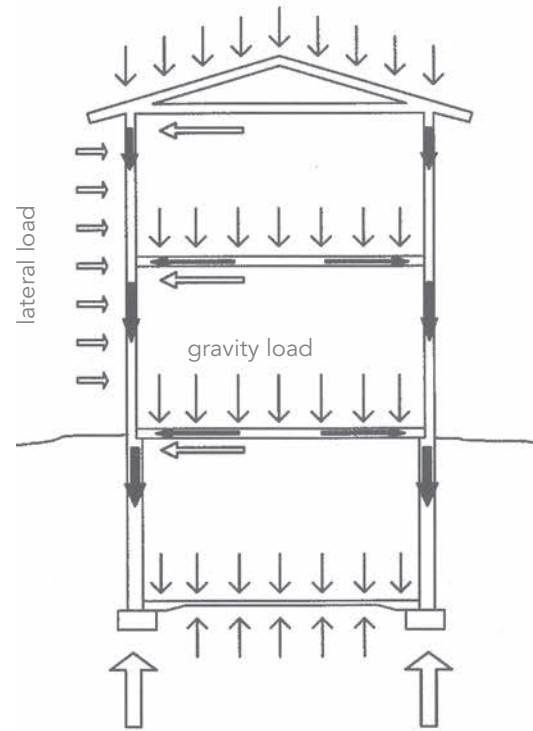

Fig. 2. Gravity and lateral loads.

## Wind Loads

Wind exerts varying forces across the building's façade, and the primary lateral load-resisting system must meet code requirements to handle those forces.

Wind pressures act directly on the windward side of a building, but they also create a pulling or suction force on the leeward side. This means that the exterior of the entire building must be able to resist both inward and outward pressure.

In addition, wind can create an upward or suction pressure on roofs made of lightweight material. For instance, a roof consisting of metal decking, thin insulation, and a membrane roof material without ballast may encounter a net upward force.

Roof shape (gable, sawtooth, etc.) may influence net uplift pressures from wind. Curved roofs can actually experience both upward and downward pressure simultaneously as the wind pushes down on the top part of the curve and pulls up from the lower part of the curve. This distribution of downward and upward pressures is similar the principles of air pressure and lift that act on an airplane wing.

The structure must transfer these wind-related forces properly. The façade should transfer the horizontal load to the adjacent floor or roof. From there, the floor and roof systems must have a means to distribute those horizontal forces to some kind of lateral load-resisting system such as diagonal bracing or shear walls.

Floors and roofs that are generally solid or without large openings may behave as diaphragms, which act as a single plane with the connecting beams, girders, and columns.

Picture a piece of cardboard held up by a series of vertical columns. When you push the cardboard horizontally, all of the columns connected to the board will move in unison. A typical floor slab is a rigid diaphragm, just like that piece of cardboard, and that lateral shift is precisely what happens when the diaphragm plane created by a roof or floor is laterally loaded. Horizontal diaphragms are an efficient way to transfer the horizontal loads at each level of a building to the lateral load-resisting systems.

Should a large opening such as an atrium, a skylight, or a raised floor interrupt the diaphragm, the lateral or horizontal loads may not flow easily to the lateral load-resisting systems. If that is the case for your project, the structural engineer may create an alternate diaphragm system such as a horizontal truss system that uses the floor beams and/or girders.

## Seismic Loads

Earthquakes and other seismic events generally exert horizontal force on structures, but they can also occasionally create vertical force, too.

The weight of the various levels on a building have a direct impact on the forces that building experiences during a seismic event. Diaphragms come into play to transfer the horizontal forces to the structure's primary lateral load-resisting systems.

The building shape and the positioning of the lateral load-resisting systems can have a big impact on a structure's sensitivity to seismic forces. If your project is in an area with significant seismic activity, you may want to consider a very regular building plan to effectively handle these forces.

## Lateral Systems

You should start thinking about the lateral load-resisting system(s) in your project early in the planning phase. You'll also want to bring in your team's structural engineer early to can determine which type of system will work best for your specific building height and configuration and specify where the system should be located.

You'll work closely with the structural engineer to balance the lateral resistance requirements of the structure with your architectural vision.

One project may use multiple types of lateral systems because each system has its own strengths, limitations, and potential architectural implications. There are three common types of lateral resisting systems: braced frames, rigid frames, and shear walls.

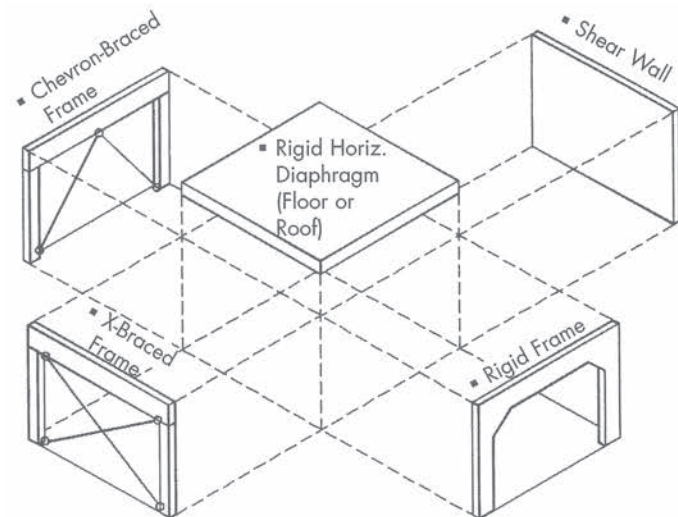

Fig. 3. Horizontal diaphragm/lateral load resisting interface.

## Braced Frames – General

There are several variations on the braced-frame model, using cross-brace, chevron brace, inverted chevron brace, and eccentric brace systems. The chevron and inverted chevron braces can be stacked to create a striking two-part cross-brace like those seen on 875 N. Michigan Avenue in Chicago.

The location of doors and/or windows on the braced frame frequently determine the bracing configuration for the structure.

Eccentric bracing can help dissipate seismic forces through the beam or girder and therefore is commonly used in areas with a lot of seismic activity.

Braced frames are generally more cost-effective than other lateral systems.

## Cross-Bracing

The cross-brace frame, represented in Figures 4 and 5, is perhaps the most commonly used system. Figure 4 shows a typical floor framing plan with cross bracing denoted by the dashed-line drawn between two center columns. The solid lines indicate the floor beams and girders.

Figure 5 depicts a typical multi-floor building elevation with cross-braced bays beginning at the foundation level. While Figure 5 shows only one bay of bracing, the height and size of the specific structure may call for bracing multiple bays along a given column line. As with all braced-frame configurations, it's important to establish the location of these bays quite early in a project's development.

Each intersection will have a common "work point" at which the centerlines of a column, beams, and diagonal members intersect. Gusset plate connections are used to join the steel members because all of them can't physically intersect at the work point. Figure 6 illustrates a typical beam-to-column joint for a cross-braced frame.

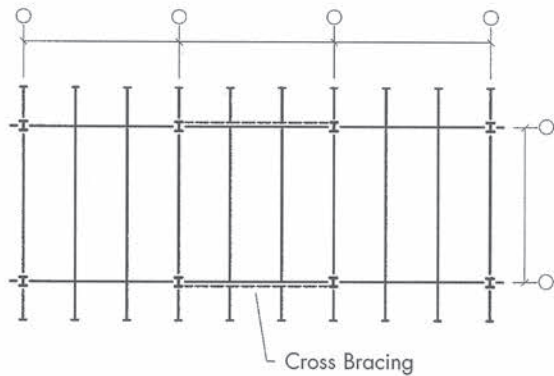

Fig. 4. Typical floor plan with cross bracing.

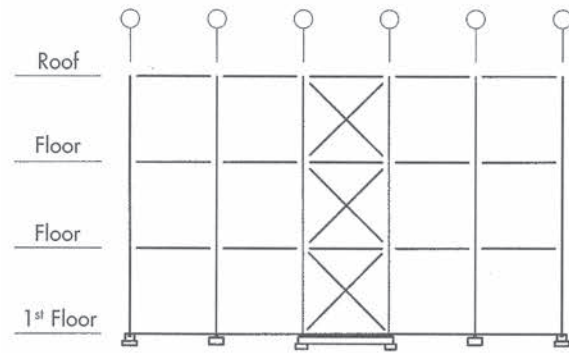

Fig. 5. Cross-braced building elevation.

When a building exceeds two or three stories, the diagonal members may support substantial loads that require large gusset plates to be placed directly next to the column and beams. These plates can take up space that may otherwise be required for mechanical and plumbing systems as well as architectural soffit details. To avoid costly field revisions during construction, it's important that the structural engineer provide the architect with information about the approximate size of the gussets in the planning phase.

Cross-braced bays make the most of steel's strength in tension to efficiently use small structural shapes. When a tension-only cross-braced system experiences a horizontal force from wind or a seismic event, only one leg of the cross-brace will provide resistance. When the load comes from the opposite direction, the other leg will become active in its place.

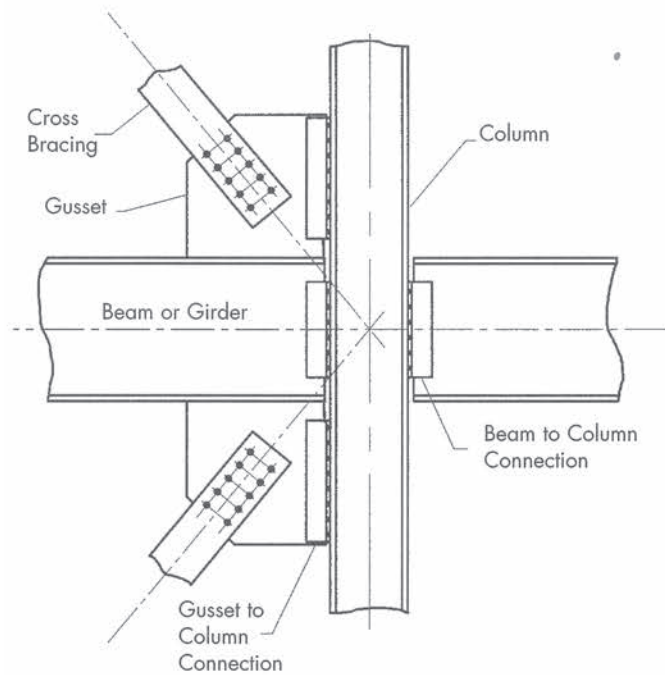

Fig. 6. Typical beam to column brace connections.

## Chevron Bracing

Chevron bracing is a modified brace-frame form that generally allows for doorways or corridors in the center of the bays.

Figure 7 shows a typical floor framing plan with the bays using chevron bracing, as denoted by the dashed-line drawn from between the two center columns. The solid lines indicate the floor beams and girders. Figure 8 shows a typical multi-floor building elevation using chevron bracing.

Gusset plates (similar to the cross-brace elements shown in Figure 6) typically connect chevron brace elements to associated beams and columns. The members can be either welded or bolted together, depending on processes at the steel fabrication shop or aesthetic considerations.

In situations where the chevron brace diagonal members attach to the structure above, the layout and coordination of mechanical ductwork and utility piping above the doorways and corridors must account for the depth of the gusset plate connection.

This bracing configuration subjects members to gravity compressive loads. Each of the bracing members is considered active in the analysis of the system when lateral loads are applied. As a result, the bracing elements experience both tensile and compressive forces.

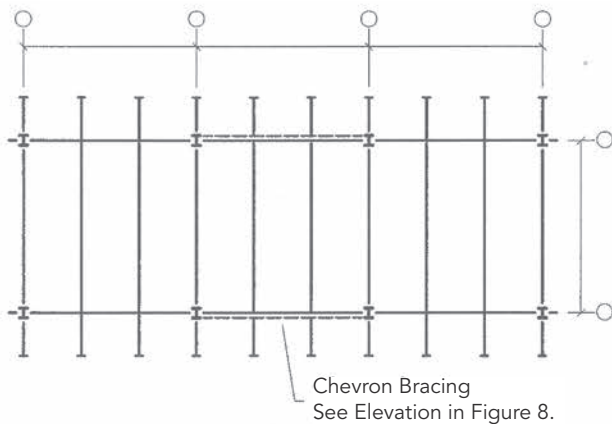

Fig. 7. Typical floor plan with chevron bracing.

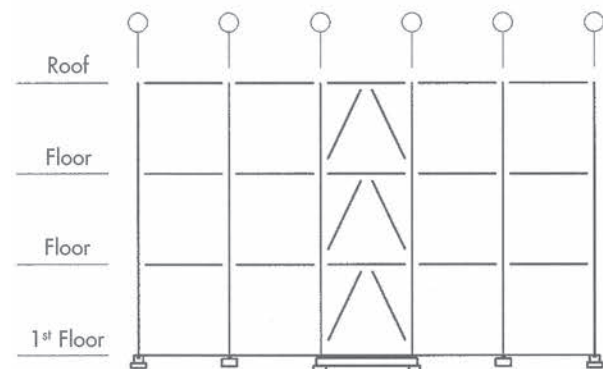

Fig. 8. Elevation with chevron bracing.



## Eccentric Bracing

Eccentrically braced frames are very similar to chevron-braced frames. In both systems, the general configuration is a rotated “K” shape with the brace connected to a column and to the beam/girder at the level above. However, brace members intersect at the same point in a chevron-braced frame; that is not the case in an eccentrically braced frame. You can see this condition in Figure 9.

An eccentric brace is commonly used in seismic regions where a structure must have a significant amount of ductility or energy absorption. The segment of beam/girder located between the diagonal bracing member is designed to “link” the diagonal braces and help the system resist lateral loads caused by seismic activity. An eccentrically braced system is typically more expensive than a traditional chevron brace system because it uses larger beams and girders and because the brace connections are more complex.

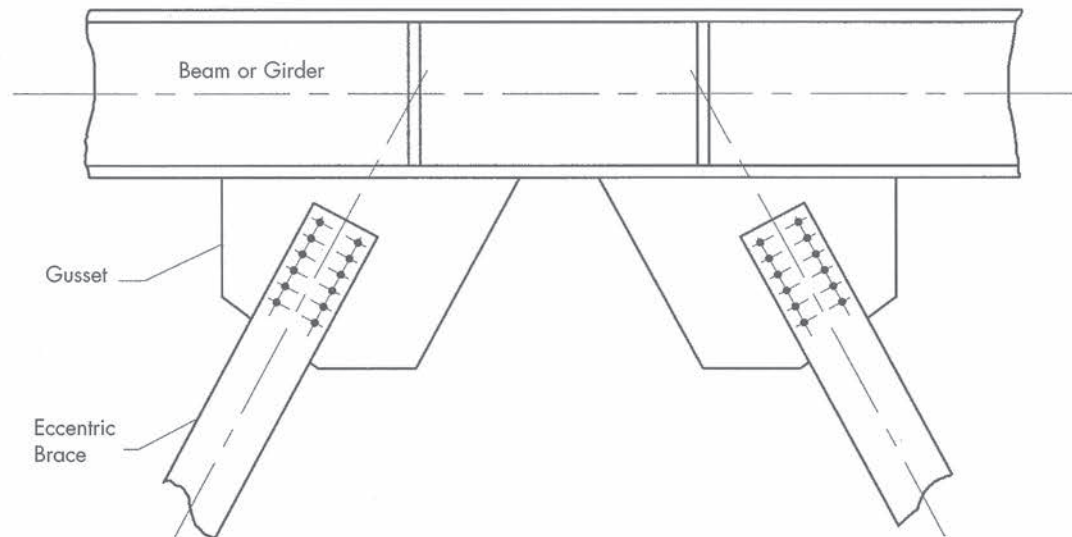

Fig. 9. Eccentric brace with typical brace to beam connection.

## Rigid Frames

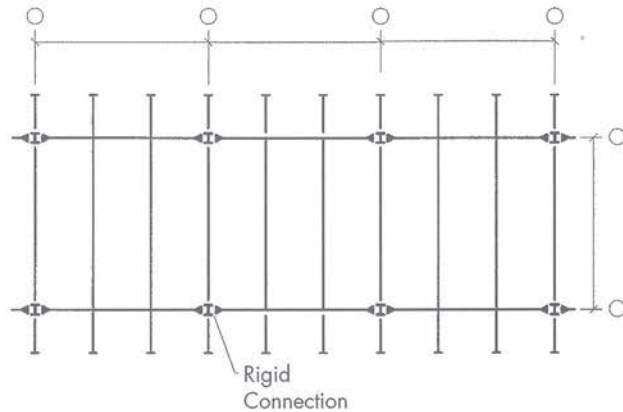

Fig. 10. Typical floor plan with rigid frames.

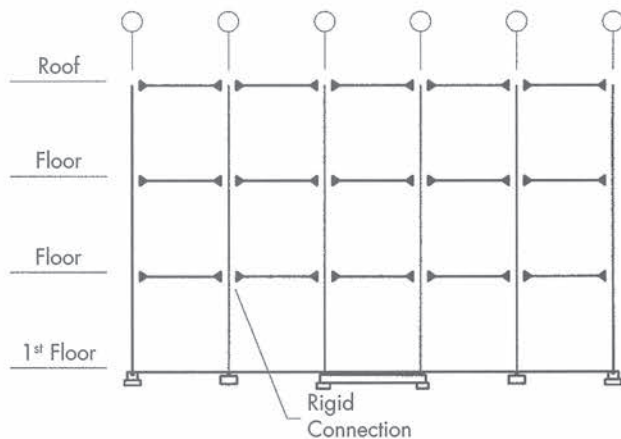

Fig. 11. Rigid frame building elevation.

Rigid frames, or moment frames, are used when the architectural design or some other constraint does not allow for diagonally braced frames. This type of lateral resisting system incorporates rigid welded or bolted connections between the columns and the beams/girders. Rigid frames are generally more expensive and less efficient at resisting lateral loads than a braced-frame system. However, low-rise building spans frequently use rigid frames when the bays can't accommodate diagonal braces.

It's best to have well-proportioned bays with shorter span beams to manage building drift. This is one of the challenges of working with a rigid frame system.

Figures 10 and 11 show a floor plan and building line elevation representing a rigid frame system. Figure 10's solid "triangles" are typically used to indicate rigid connections between the steel components. Figure 12 shows a typical moment connection between the beam/girder and a column; these connections typically use a shear connection along the web to support the gravity loads on the member, as well as field-welded beam-flange to column-flange connections to resist lateral loads.

Rigid frame moment connections can be four to six times as expensive as a typical gravity connection because they require more preparation time and field welding. Column stiffener plates are sometimes required, at additional cost, between the flanges of the column to prevent buckling of the column webs.

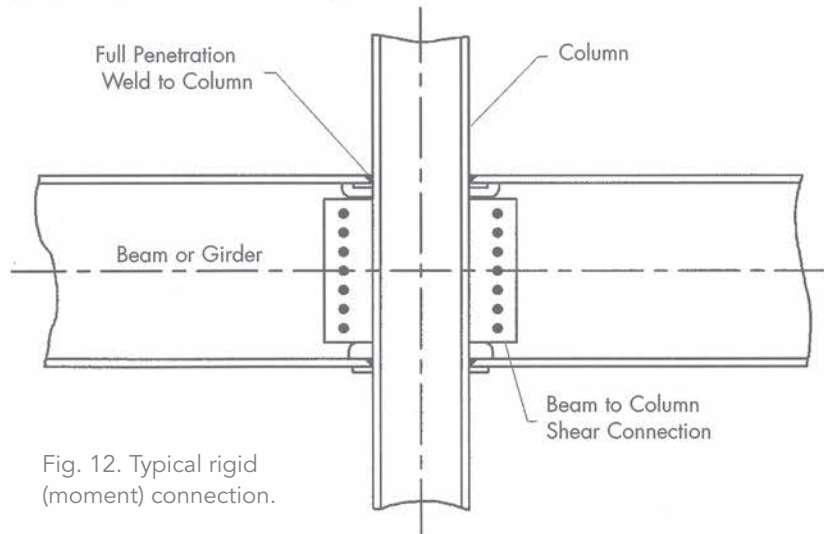

Fig. 12. Typical rigid (moment) connection.

Sometimes, when the forces are relatively small, it's possible to use a bolted end-plate moment connection in place of a field-welded moment connection. It is important to note that this type of joint requires that all vertical utility ductwork and piping be free and clear of the column and beam/girder flanges. With a rigid frame, you generally want to avoid modifications to the beam/girder flange, such as coping or web openings to allow passage of piping or other utilities. The structural engineer on your team is a good resource in situations that may call for such modifications.

## Shear Walls

This type of lateral load-resisting system engages a vertical element of the building, usually concrete or masonry, to transfer the horizontal forces to the ground by a primary shear behavior. Shear walls are inherently stiff elements and are therefore extremely effective at resisting lateral wind loads. Steel shear walls are also now available, as well as composite plate shear wall cores for tall buildings that use a non-proprietary system called SpeedCore. The SpeedCore system can significantly increase the speed of erection, and that shorter construction time can save a significant amount of money. Visit [www.aisc.org/speedcore](http://www.aisc.org/speedcore) to learn more about this revolutionary core system.

You can find additional resources on a broad array of engineering-related topics at [aisc.org/engineeringbasics](http://aisc.org/engineeringbasics).



2015 AISC IDEAS<sup>2</sup> Award  
Florida Polytechnic University  
IST Building, Lakeland, Fla.  
Photo: Macbeth Photo



# Finishes, Coatings, and Fire Protection

.....  
**SECTION**



## Fire can strike anywhere and anytime, so it's crucial to plan for the worst.

Building codes specify the number of hours a structure must withstand a given temperature, based on a variety of characteristics of the building in question. There are three key considerations when creating a fire protection plan: life safety, fire suppression, and protection of the structure. We'll focus on common ways to protect a steel structure here. You can find more information about life safety, fire suppression, and protection of the structure in AISC's Design Guide 19: *Fire Resistance of Structural Steel Framing*.

## Effect of Temperature on Steel

Even noncombustible materials such as steel can be affected by high temperatures. However, because structural elements are not usually loaded to their full design strength, even bare steel may have sufficient load-carrying capacity to withstand the effects of fire.

In general, structural steel retains 60% of its ambient temperature yield strength at 1,000 °F—and most building fires exceed that temperature at some point.

The standard ASTM fire test uses constantly increasing temperatures, assuming that the fire has an infinite supply of fuel and the members are loaded to full design load. When building codes specify fire-resistant construction based on the results of these tests, structural steel elements must be insulated with protective materials.

Many such materials and systems have performed well in testing. Contractors must take great care to install all of them properly while maintaining the physical integrity that makes them insulate so well.



## Intumescent Coatings

Intumescent coatings are epoxy-based, paint-like mixtures applied to the primed steel surface. When subjected to high heat, these coatings expand to many times their original thickness, forming an insulating blanket that protects the steel member from heat. These coatings allow for fire ratings of up to four hours.

Intumescent coatings can effectively balance architecturally exposed structural steel design elements with fire rating requirements. However, intumescent coatings are more expensive, costing several times the price of common spray-applied systems. The cost of intumescent coatings increases as the required fire rating increases. These coatings are generally used only to protect exposed steel.

A single member may frequently have a combination of systems: spray-applied fibrous systems on hidden portions, and intumescent coatings on exposed portions.



## Gypsum

Gypsum is commonly used for fire protection, and it comes in a variety of formats. Adding lightweight mineral aggregates such as vermiculite and perlite can significantly increase the effectiveness of gypsum-based fire protection systems.

Gypsum plaster can be applied over metal or gypsum lath. If your project uses gypsum plaster, the contractor must be sure to properly install the lath, then apply the required thickness of the properly proportioned mix.

Gypsum wallboard, meanwhile, can be installed over cold-formed steel framing or furring and comes in a few different varieties. Type X wallboards have specially formulated cores that provide greater fire resistance than regular wallboard of the same thickness. In addition, many manufacturers produce proprietary wallboards that are even more resistant to fire. It is important to verify that the wallboard used in construction is the one specified in the final design. In addition, special types and spacing of fasteners and furring channels may be required.



## Spray-applied Fire-Resistive Material

The most widely used fire protection materials for structural steel are mineral fiber and other cementitious materials that are sprayed directly onto the contours of beams, columns, girders, and floor/roof decks. These materials are proprietary, so it's particularly important to mix and apply each product according to the manufacturers' instructions. UL publishes fire-resistant designs with different types and thicknesses of material.

Be sure to remove dirt, oil, and loose scale before applying these materials, as defects like these can affect adhesion. Light corrosion is fine and will not have an adverse effect on adhesion.

Steel will likely arrive at your construction site after being primed by the fabricator. Be sure to use a fireproofing material that is approved for application over a primer to ensure a good bond between the sprayed material and the primed steel member.

A number of materials are approved for this application. In addition, research has shown that it is not necessary to paint structural steel when it is protected, such as with spray-applied fire protection materials, or fully enclosed between the inside and outside walls of a building.



## Suspended Ceiling Systems

Suspended ceiling systems protect floors, beams, and girders. UL publishes fire resistance ratings for each of the proprietary systems that are available. When planning to use a suspended ceiling system, remember to carefully protect openings for light fixtures, air diffusers, and similar accessories. The manufacturer will provide specific instructions to facilitate that protection as well as the integration of ceiling tile, grid, and suspension systems. Be sure to follow those instructions carefully.

In case of load transfer trusses and/or girders that support loads from more than one floor, building codes may not allow the use of suspended ceiling systems.



## Concrete and Masonry

In past decades, concrete was the most widely used material for structural steel fire protection, though its relatively high thermal conductivity does not make it a particularly efficient choice. As a result, concrete is no longer widely used for the purpose of fire protection.

A notable exception is the growing use of composite construction, such as concrete-encased steel columns. Concrete and masonry are also sometimes used to protect steel columns for architectural purposes or when substantial resistance to physical damage is required.

AISI offers design information on fire resistance of steel columns encased in concrete or protected with precast concrete column covers. Information on using concrete masonry or brick is available from the National Concrete Masonry Association, and the Brick Institute of America, respectively.

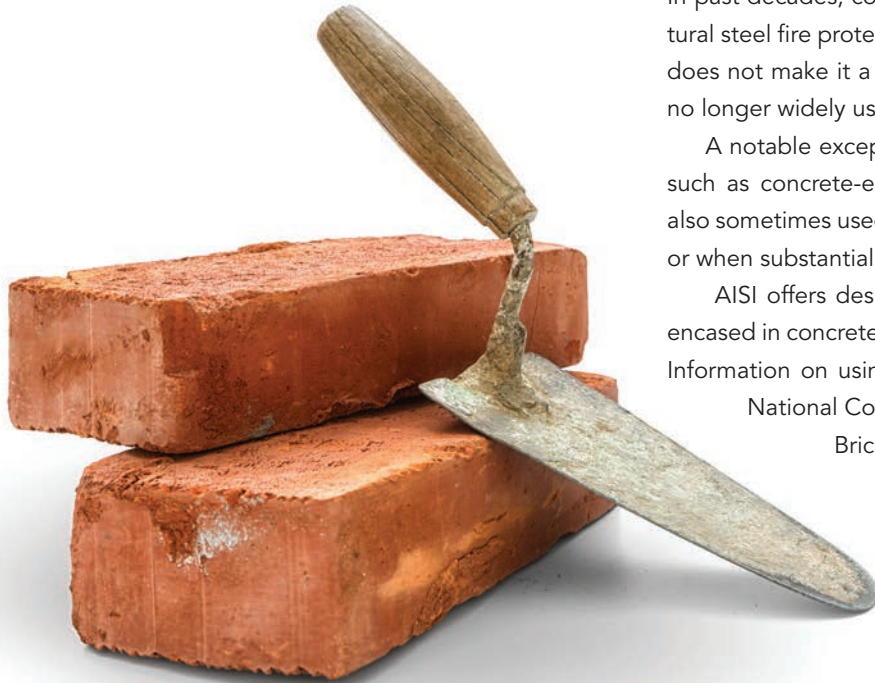

You can find more information regarding life safety, fire suppression, and protection of the structure at **[aisc.org/fireproofing](https://aisc.org/fireproofing)**.



# Sound Isolation and Noise Control

.....  
**SECTION**



No one likes a noisy building. Your team should start thinking about noise intrusion and other acoustic objectives early in the design process—particularly as acoustic requirements become more stringent and “green” design emphasizes the effects of noise pollution.

Acoustic performance comes down to the selection and assembly of building elements, not the material types and framing systems. A good design will create the desired sound characteristics using any material and any frame system.

AISC’s Design Guide 30: *Sound Isolation and Noise Control in Steel Buildings* outlines a logical approach to achieve the desired acoustic environment. Please refer to the Design Guide for further information.

To begin, one must determine a reasonable sound level for a given space. For example, how quiet does an office need to be? What about a large conference room? The building finishes you choose will have an impact on the noise level. The table below outlines the sound absorption coefficients of common building finishes.

### SOUND ABSORPTION OF COMMON BUILDING FINISHES

Material	Absorption Coefficients, Hz						Noise Reduction Coefficient
	125	250	500	1,000	2,000	4,000	
wood floor	0.15	0.11	0.10	0.07	0.06	0.07	0.10
carpet, on concrete	0.02	0.06	0.14	0.37	0.60	0.65	0.30
5/8-in. gypsum board on 3 5/8-in. steel studs, insulation in cavity	0.13	0.06	0.04	0.03	0.03	0.03	0.04
1-in. fabric-wrapped glass fiber panel, wall-mounted	0.05	0.32	0.82	1.0	1.0	1.0	0.80
2-in. fabric-wrapped glass fiber panel, wall-mounted	0.29	0.82	1.0	1.0	1.0	1.0	1.0
suspended mineral fiber acoustic ceiling tile (typical)	0.25	0.30	0.50	0.75	0.75	0.75	0.60
suspended glass fiber acoustic ceiling tile (typical)	0.75	0.90	0.80	0.95	1.0	1.0	0.90

Table 3–1 found in Design Guide 30: *Sound Isolation and Noise Control in Steel Buildings*.

Finishes are only one part of the equation. How many people will be in the space? For example, an office may have very different requirements than a recording studio or performance space. The following table is a good reference for the background noise criteria (NC) ratings of various settings.

## BACKGROUND NOISE CRITERIA (NC) FOR VARIOUS OCCUPANCIES

Building Types	Rooms	NC Rating	Reference(s)
residences	living areas	30	<i>ASHRAE Handbook: HVAC Applications</i> , Ch. 48 (ASHRAE, 2011)
	bathrooms, kitchens	35	<i>ASHRAE Handbook: HVAC Applications</i> , Ch. 48
hotels	guestrooms, suites	30	<i>ASHRAE Handbook: HVAC Applications</i> , Ch. 48
	meeting/banquet rooms	30	<i>ASHRAE Handbook: HVAC Applications</i> , Ch. 48
	lobby/support/service	40	<i>ASHRAE Handbook: HVAC Applications</i> , Ch. 48
office buildings	private offices	30	<i>ASHRAE Handbook: HVAC Applications</i> , Ch. 48; P-100: <i>Facilities Standards for the Public Buildings Service</i> (GSA, 2010)
	teleconference rooms	20 to 25	<i>ASHRAE Handbook: HVAC Applications</i> , Ch. 48; P-100: <i>Facilities Standards for the Public Buildings Service</i>
	open-plan offices	40	<i>ASHRAE Handbook: HVAC Applications</i> , Ch. 48; P-100: <i>Facilities Standards for the Public Buildings Service</i>
recording studios, performing arts centers	performance spaces, studios	below 15 or threshold of hearing	ANSI/ASA S12.2 Annex E: "Criteria for Recording Studios and Other Low-Noise Situations" (ASA, 2008)
	rehearsal spaces	20 to 25	<i>Acoustical Design of Music Education Facilities</i> (McCue and Talaske, 1990)
hospitals	patient rooms, exam rooms, doctors' offices	30 to 40	<i>Guidelines for Design and Construction of Health Care Facilities</i> (FGI, 2010)
	teaching lab	35 to 45	<i>Guidelines for Design and Construction of Health Care Facilities</i>
	multiple-occupant patient care areas	35 to 45	<i>Guidelines for Design and Construction of Health Care Facilities</i>
	NICU	25 to 35	<i>Guidelines for Design and Construction of Health Care Facilities</i>
courts	courtroom	25 to 30	<i>U.S. Courts Design Guide</i> (GSA, 2007)
laboratories	research lab <sup>a</sup>	35 to 50	<i>ASHRAE Handbook</i>
schools	classrooms	30	ANSI/ASA S12.60 (ASA, 2010) (35 dBA and NC-30 are roughly equivalent)
religious facilities	worship spaces	15 to 25	<i>Worship Space Acoustics</i> (Kleiner et al., 2010); <i>ASHRAE Handbook</i>

<sup>a</sup> Depending on communication requirements. Teaching labs should have lower background sound levels than pure research labs, with minimal requirements for speech communication. : Table 4–1 found in Design Guide 30: *Sound Isolation and Noise Control in Steel Buildings*.



Next, consider what other elements might add additional noise. Where are loud conversations or amplified presentations likely? Where do you anticipate a lot of foot traffic? What mechanical (HVAC) equipment serves the various rooms, and how much noise does that equipment make? How much noise is outside the building? All of these items must be taken into consideration when achieving a desired Sound Transmission Class (STC) for a specific space. As an example, the table below outlines different STCs for spaces adjacent to a core learning space within a school.

### SOUND ISOLATION CRITERIA IN ANSI/ASA S12.60—PART 1<sup>a</sup>

Space Adjacent to a Core Learning Space	Minimum Sound Isolation (STC)
another core learning space, therapy room, health care room, or another space requiring acoustical privacy	50
common-use and public-use toilet room	53
corridor (not including the door), stair, office, or conference room	45
music room, performance space, mechanical equipment room, cafeteria, or gymnasium	60

<sup>a</sup> Summarized from ANSI/ASA S12.60 Table 4 (ASA, 2010).

: Table 5–2 found in Design Guide 30:  
 : *Sound Isolation and Noise Control in*  
 : *Steel Buildings.*

Once you understand the potential noise sources and hotspots, you can start to consider how noise for each source travels to a given space and predict the acoustic environment in that space. Once you have an estimate, you can start to figure out what noise reduction interventions that space might need and think about how sound might be transmitted between spaces. For instance, sounds can be transmitted between rooms through walls, or through gaps under doors. Below, you'll find tables and figures outlining typical wall and ceiling assemblies, what STC ratings they can achieve, and a typical detail of these elements.

## SOUND ISOLATION PROPERTIES OF COMMON STUD-FRAMED WALLS

Studs	Wall Facing, GBW, Side 1	Wall Facing, GBW, Side 2	Batt Insulation, <sup>a</sup> in.	Stud	Stud Spacing (o.c.), in.	STC	Data Sources
	Number of Layers, Thickness, in.	Number of Layers, Thickness, in.		Size, in., Gauge			
Single	1 layer, 5/8	1 layer, 5/8	none	3 5/8, 25	24	38 to 42 38	1 2
Single	1 layer, 5/8	1 layer, 5/8	3	3 5/8, 25	24	43 to 44	1, 3
Single	1 layer, 5/8	1 layer, 5/8	3.5	3 5/8, 25	16	44 39 to 49 <sup>b</sup>	3 2
Single	1 layer, 5/8	1 layer, 5/8	3	3 5/8, 16 or 20	16 or 24	38 to 39	3
Single	2 layers, 5/8	1 layer, 5/8	3.5	3 5/8, 25	24	47 to 49	1, 3
Single	2 layers, 5/8	1 layer, 5/8	3.5	3 5/8, 16	16	42	3
Single	2 layers, 1/2 or 5/8	2 layers, 1/2 or 5/8	3 or 3.5	3 5/8, 25	24	50 to 54 52 51 to 58	1 3 2
Single	2 layers, 1/2 or 5/8	2 layers, 1/2 or 5/8	3.5	3 5/8, 25	16	49 52 to 56	3 2
Single	2 layers, 5/8	2 layers, 5/8	3.5	3 5/8, 16 or 20	16	44, 45	3
Double	1 layer, 5/8	1 layer, 5/8	2.5 × 2	2 1/2, 25	24	55	2
Double	2 layers, 5/8	2 layers, 5/8	2.5 × 2	2 1/2, 25	24	64	2

1. California Office of Noise Control (DuPree, 1981).

2. National Research Council of Canada Institute for Research in Construction (IRC) Report IRC-IR-761 (Halliwell et al., 1998) and Report RR-343 (Kodur et al., 2013).

3. Bétit (2010).

: Table 8–1 found in  
: Design Guide 30:  
: *Sound Isolation  
: and Noise Control  
: in Steel Buildings.*

<sup>a</sup> Per Report IRC-IR-761 (Halliwell et al., 1998); results in the same STC ranges with fiberglass batt, mineral fiber and cellulose insulation.

<sup>b</sup> A review of published laboratory test data indicates that some IRC tests (Halliwell et al., 1998) have produced higher STC results of nominally identical constructions than other tests (at IRC and elsewhere). These higher test results should not be used as the basis of design decisions. Some of these data are presented here to illustrate the wide range of published data.

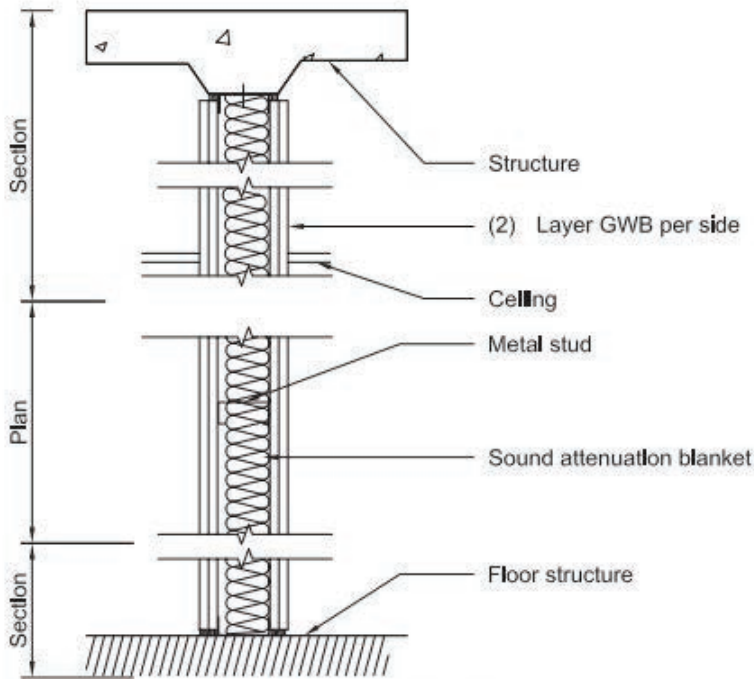

Provide a continuous bead of acoustical sealant around ceiling and floor perimeters of partition.

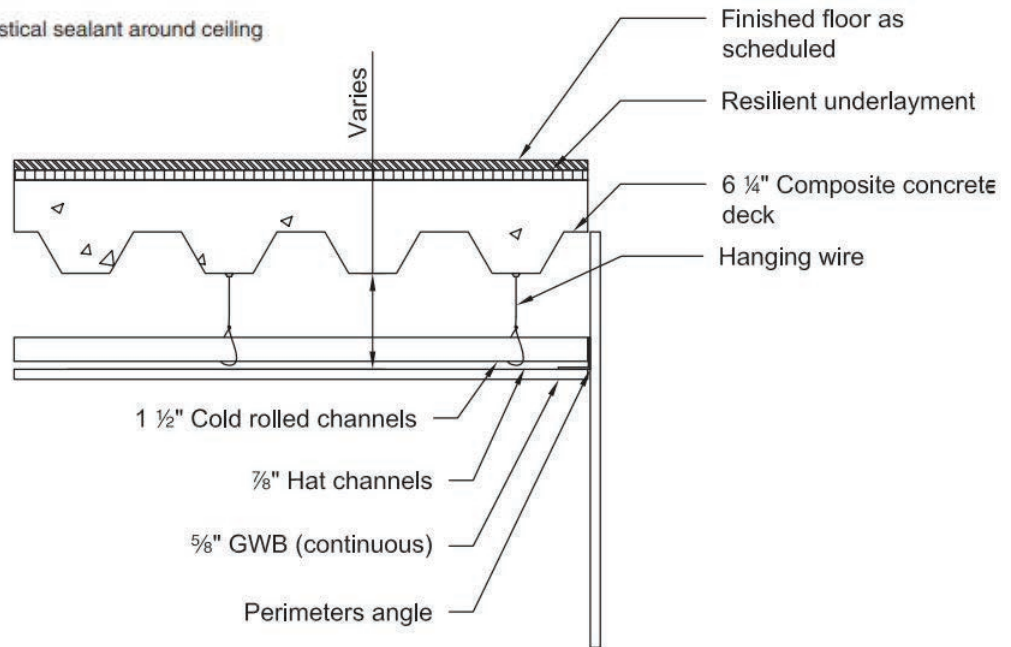



## SOUND ISOLATION OF FLOOR/CEILING ASSEMBLIES

Floor/Slab/Deck	Insulation	Ceiling Suspension	Ceiling	STC	Data Source
10-in. hollow core concrete panels, 64 psf	–	–	–	50	1
6-in. concrete slab, 75 psf	–	–	–	55	1
8-in. concrete slab, 95 psf	–	–	–	58	1
6-mil vinyl floor on 1/10-in. resilient underlayment on 6 1/4-in. total-thickness lightweight concrete on 3-in. 18-ga. galvanized composite metal floor deck	3-in. mineral fiber board	3-in. 16-ga. wire hangers	1 layer, 1/2-in. lightweight GWB	55	2
3/4-in. hardwood floor on 1-in. resilient underlayment on 6 1/4-in. total-thickness lightweight concrete on 3-in. 16-ga. galvanized composite metal floor deck	3-in. glass fiber batt	resilient clip with 4-in.-deep angle, steel stud framing	2 layers, 5/8-in. GWB	FSTC* 69	3
3 1/2-in. normal-weight concrete over Type 0.6C, 26-ga. steel deck (0.562 in.-deep), on 10K1 open-web steel joist, 24 in. o.c.	none	resilient clips 48-in. o.c. with 25-ga. hat channel, 24 in. o.c.	1 layer, 5/8-in. GWB	60	3
5-in. concrete slab, 42 psf, on metal deck	none	16-in.-deep wire hangers	mineral fiber ACT in T-grid	60	4

1. California Office of Noise Control (DuPree, 1981).
2. NGC Testing Services (NGC, 2014a).
3. PAC-International laboratory test data (PAC International, 2014).
4. Long (2014).

\*STC value was obtained in field test rather than in the lab.

- Table 8–6 found in
- Design Guide 30:
- *Sound Isolation*
- *and Noise Control*
- *in Steel Buildings.*

For more information on Sound Isolation and Noise Control, please visit [aisc.org/soundisolation](https://aisc.org/soundisolation).



# Sustainability and Resilience

.....

**SECTION**

**5**



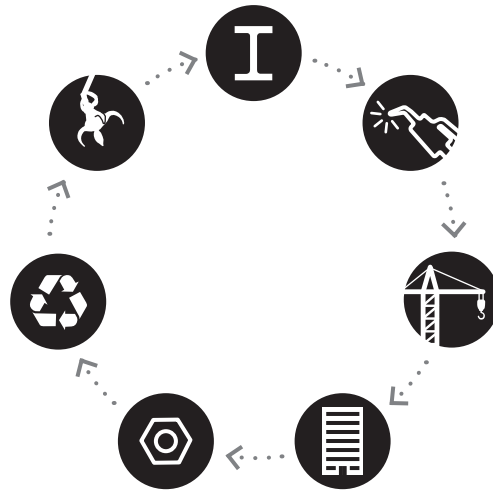

## Sustainability

Structural steel is infinitely recyclable, which makes it a superior material for green construction.

In fact, domestically produced structural steel contains an average of 93% recycled content, and 98% of that steel is recycled back into new products at the end of a structure's life. That's one reason the U.S. Green Building Council's LEED Green Building Rating System gives maximum credit to structural steel for its contribution to a structure's overall rating.

The ability to recycle steel over and over again makes it a unique cradle-to-cradle material, in contrast with other materials that can only be used once.

Over the past three decades, the steel industry has reduced greenhouse gas and overall emissions by 36% and increased the water recycling rate of steel production to 95%. As the green building movement grows, more and more building owners, architects, engineers, and contractors are selecting structural steel framing systems to meet sustainable design and construction goals.

## CRADLE-TO-CRADLE LIFE CYCLE OF STRUCTURAL STEEL



### Structural Steel Mill

Overall carbon emissions have been reduced by 36% since 1990 and steel production has a water recycling rate of 95%, resulting in a net consumption of only 70 gallons per ton.



### Fabrication

More than 1,700 steel fabricators in the United States supply fabricated structural steel for building and bridge projects; these fabricators purchase structural steel shapes and plates and fabricate the steel to meet the unique requirements of each project.



### Construction and Erection

Steel is fabricated off site to strict tolerances and can be erected quickly in the field, meaning fewer workers on the job site, safer working conditions, shorter construction schedules and reduced emissions from construction equipment.



### Building Operation

Long-span beams with open, column-free spaces attract potential occupants. In addition, steel framing can more easily be adapted for future changes in loading conditions, vertical expansion and changes in occupancy when compared to other framing systems.



### Deconstruction

Beams, columns and other structural steel elements removed from a building can be re-fabricated for use in new structures without having to be melted and rolled; remaining steel elements are captured as scrap and used to create new steel products!



### Scrap Collection

By weight, 81% of all steel products are recovered for recycling at the end of their life. This includes 85% of automobiles, 82% of appliances, 70% of containers, 72% of reinforcing bar and **98% of structural steel**.



### Scrap Processing

Steel is the most recycled material in the world, with domestic mills recycling more than 70 million tons of scrap each year. Currently, structural steel includes 93% recycled content!

## Resilience

A material's resilience—how it performs during and after an extreme event—is a crucial consideration for any project. Structural steel's inherent resilience as a material can address the owner's desire to maintain select building functions after an extreme event, especially when coupled with purposeful design decisions addressing resilient requirements. After such an event occurs, structural steel is more easily repaired and/or replaced than other materials.

Resilience following a blast or terrorist attack is a newer concern that further challenges the engineer's ability to design for drift. Current building codes address occupant safety during an extreme event but do not address not a structure's functionality and recovery following the event. Structural steel's durability, strength, elasticity, toughness, lack of combustibility, and resistance to decomposition make it a uniquely resilient choice for safe structures that last.







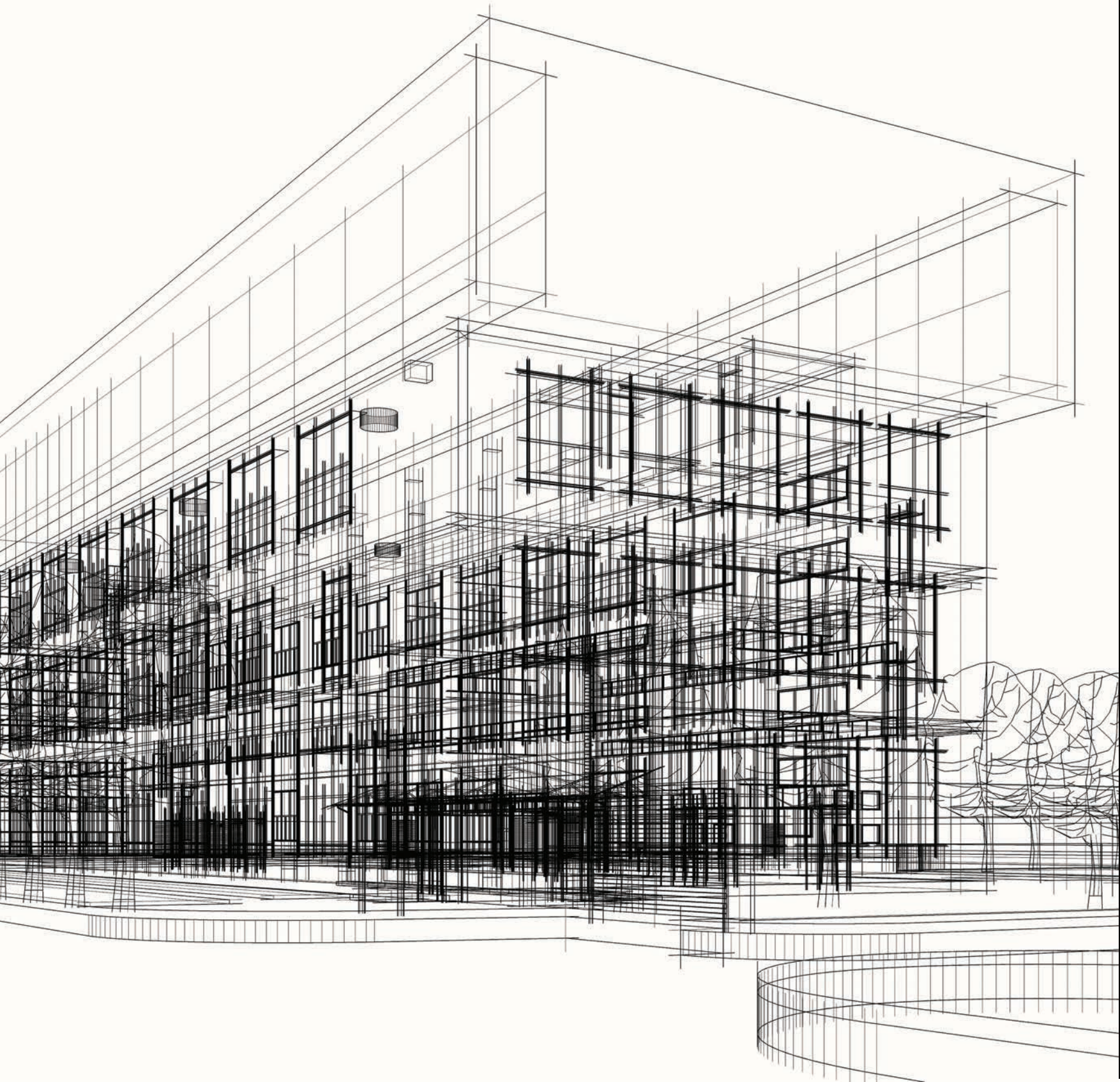

# Detailing Considerations

.....

**SECTION**





It's far easier to start a project with detailing in mind than it is to go back and take care of it later. Various building enclosure systems (or skins) have different connections to the many available steel framing systems, and you'll want to be mindful of how the two interface as you develop a project.

These few pages are not intended to be a comprehensive detailing guide. Instead, we'll identify common issues that should be addressed in early phases of a project. Bear in mind that each project and region will have different considerations when it comes to creating a weather-tight enclosure system.

The type of lateral system used in a building may have a large impact on the location of the enclosure's interior face relative to the column centerlines. If an exterior wall has diagonal bracing, the enclosure system and the interior wall finish, along with any supports, must clear the bracing members.

Usually these bracing members are rods, angles, or structural tubes (hollow structural sections, or HSS) that are located on the column centerlines. If single angles are used, the vertical leg of the member is generally attached to a gusset plate that is located directly on the column centerline. The horizontal leg should be oriented so as to avoid interference with the enclosure system, its back-up system, and the interior wall finish.

It's important to note that bracing is not required in every bay if a system uses cross-bracing. Depending on the building size and configuration, bracing may only be required in one or two bays in each primary direction of the building. Cross-braced bays can sometimes accommodate doors and windows within the bay, provided the opening's frames and supports clear the bracing members and associated connections.

You'll have more design freedom in terms of placing the enclosure or interior wall finish surfaces if the building's lateral system uses rigid moment frames or shear walls. There are, however, cost implications and detail considerations that must be addressed if alternate lateral bracing systems are used.









The following details show a floor system that comprises a steel floor deck topped with concrete. Typical floor system thicknesses range from 4 in. to 7½ in. depending on floor loads, the distance that the system must span between beams, and the required fire rating.

There are two varieties of cold-formed steel floor deck: composite and non-composite. A composite sdeck has dimples pressed into its surface. Those dimples interlock with the cured cast-in-place concrete to form the tension reinforcing in the bottom of the slab. A composite steel floor deck acts as a permanent form and as the positive bending reinforcement for the structural concrete topping.

Non-composite steel floor deck acts as permanent formwork for reinforced concrete slabs. It is only a form; the deck does not have dimples, and it does not act compositely with the concrete.

Similarly, composite and non-composite steel beams can both support the floor system. Composite beams headed studs welded to the top flange of the member after the metal deck has been installed. These studs interlock with the cured cast-in-place concrete; the concrete and steel work together as a composite unit. Non-composite beams are standard steel beams that support the metal deck and concrete topping without any interlocking studs.

Composite beams are generally lighter and shallower than non-composite framing. It should be noted, however, that all floor systems should be carefully checked for any floor vibration concerns.

Steel framing can accommodate several other types of floor systems, including cast-in-place concrete and precast concrete planks. Precast planks can span 10 ft to 40 ft between steel girders, depending on the floor load and plank thickness, but long spans of planks may require deeper steel girders.

## Exterior Masonry Walls

*A quick note: We'll use concrete masonry units (CMU) as the back-up system for the masonry details in this Guide; back-up systems can also use other materials such as metal studs.*

If you're considering a brick and CMU enclosure system, you'll need to first determine the location of the entire enclosure system relative to the column centerline. The brick and block enclosure system can completely bypass the floor slab, perimeter beam flanges, and column flanges (Figure 1). Alternately, the brick can bypass the floor slab, which will then support the CMU. Each system has advantages and disadvantages. If the masonry enclosure system bypasses the slab edge, the perimeter steel members do not support the load of the masonry at each floor, and therefore those steel members may be lighter and shallower.

The disadvantage of such an arrangement is that the weight of the entire enclosure system would be supported directly on the perimeter footings or grade beams. This may require a larger and more expensive foundation. In addition, the columns would project more into the interior spaces because they wouldn't be buried in the enclosure system at all.

The required clearances for the largest column or widest beam flange at the perimeter of the building will dictate the location of the inside face of the masonry enclosure system. In addition, masonry can only extend so high without intermediate supports. Please contact masonry industry professionals/publications for specific requirements and further guidance.

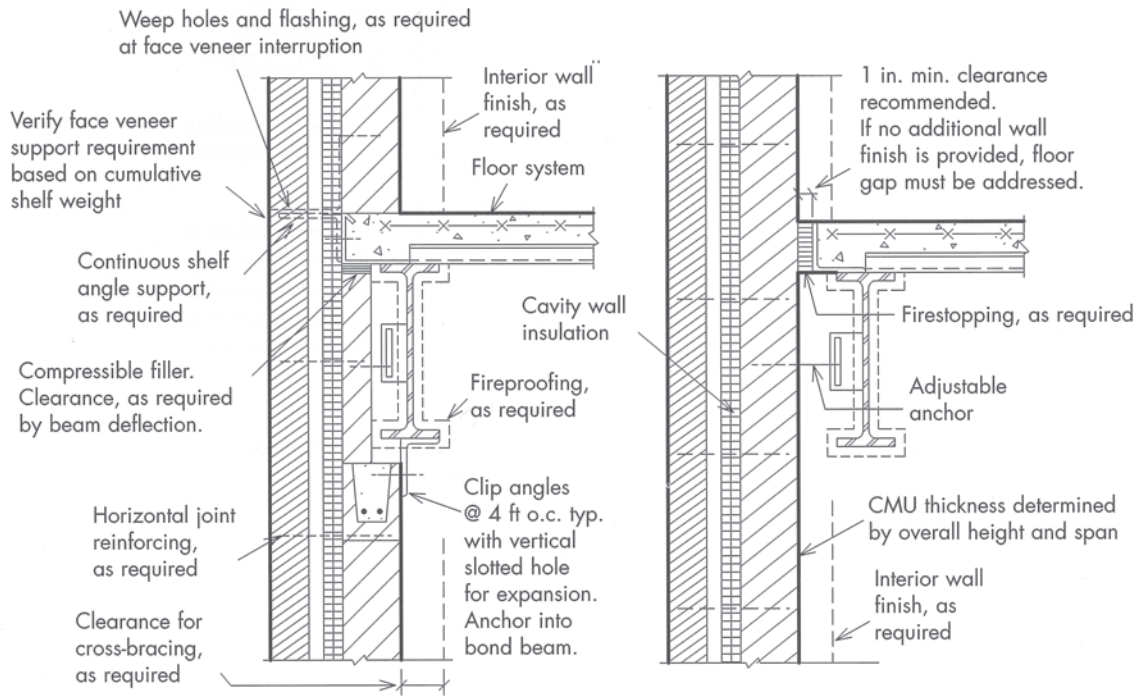

Fig. 1. Sample masonry wall section details at floor framing.



## Precast Concrete Panels

Precast concrete panels can be an attractive and cost-effective enclosure system for some applications. Precast panel systems are most economical when the panel sizes are 20 ft to 30 ft in length, and the panel width/height is limited to approximately 14 ft.

There are many ways to connect precast concrete exterior wall panels to the supporting steel frame (Figure 2). The precast panel manufacturer will generally determine the final details of the connection.

It is, however, the architect's responsibility to make adequate provisions for proper support and construction tolerance of the panels. Some precast manufacturers prefer to bear the panels on recessed pockets within the panels that are supported directly on seated connections or haunches from beams or columns. The seated connections or haunches minimize the eccentricity of the panel self-weight on the support connection. Other support options include such assemblies as structural angles or channels attached to the columns or beams which would support embedded angles located on the back of the precast panels.

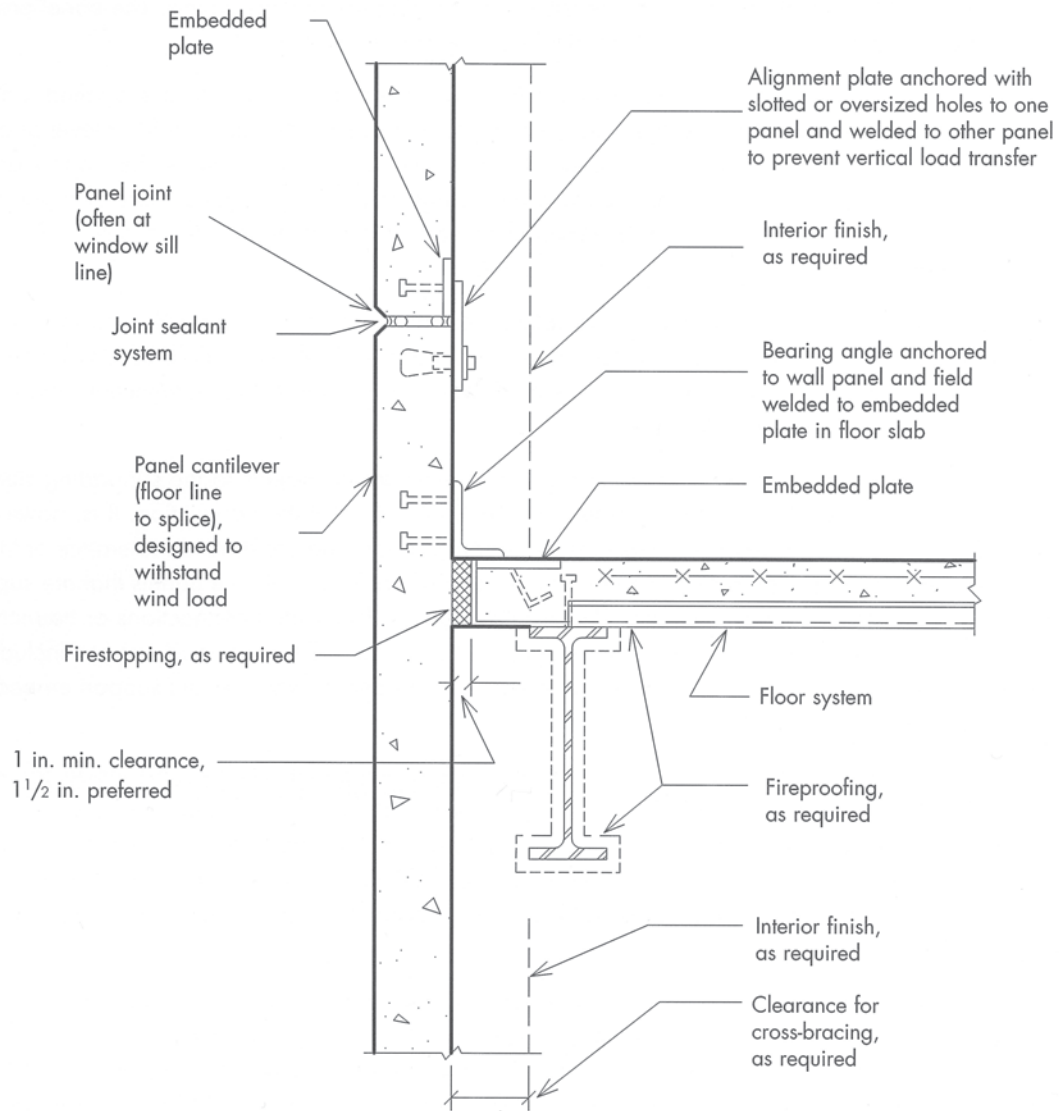

Fig. 2. Sample wall section detail at vertical span precast panels.

## Thin Stone Veneer Panels

Stone is a product of nature. As a result, thin stone veneer panels may have different physical properties—even stones from within the same quarry. For example, one granite panel may be as much as 150% stronger than another.

When selecting a thin stone veneer system, it's important to carefully consider:

- the physical properties of the selected stone
- design criteria for the veneer
- the interrelationship of the exterior wall assembly
- the structural engineering responsibilities of the stone veneer and the anchoring system

A grid strut back-up system will be required to laterally and vertically support the thin stone (Figure 3). This back-up system is generally a steel sub-frame system or a CMU wall. Please consult a stone fabricator for detailing information and deflection limitation criteria.

Because stones vary in strength, you need to pick stone panel anchors very carefully. A stronger stone requires fewer anchors, as the stone can support itself between them. There are hundreds of different anchors that are inserted into a kerf or slot cut into a hole drilled into the sides or rear of the stone panels. Choosing the appropriate anchor, based on the panel size, thickness, and back-up system is critical to the success of thin stone veneer panel systems.



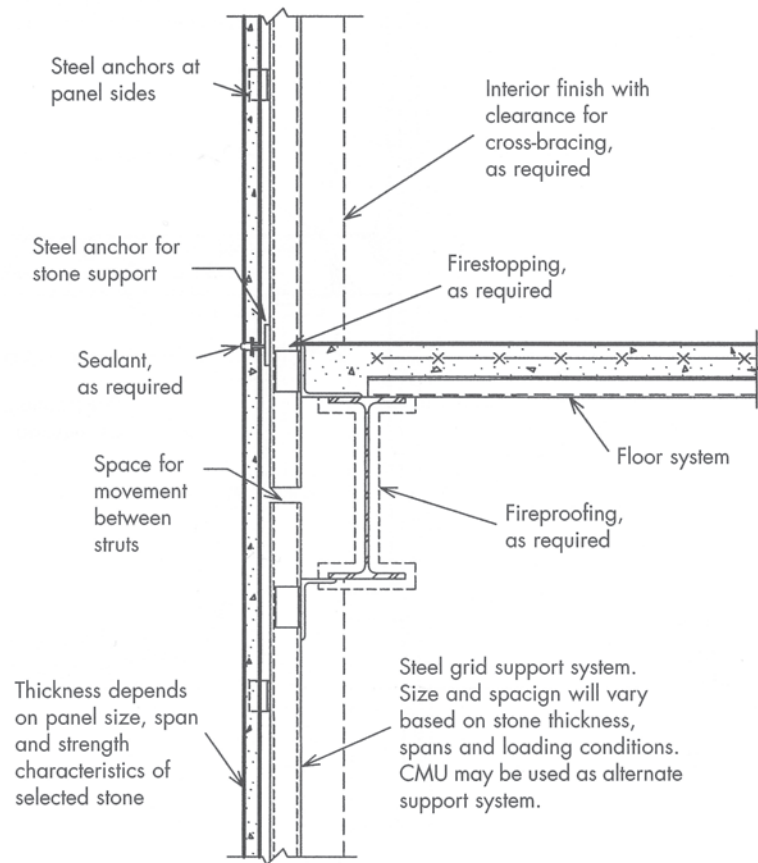

Fig. 3. Sample wall section detail for thin stone veneer panels.

## Curtain Wall Enclosure Systems

Window wall and curtain wall systems contain their own lateral load-resisting structural system. The glazing systems' mullions provide support to transfer the exterior wind loads on the glazing to the primary building structure. Generally speaking, the glazing horizontally or vertically spans the short direction between mullions, depending on the proportions and orientation of the glazing (Figure 4). Please consult a window wall manufacturer to determine practical mullion locations and depths. It should be noted that mullions can generally be reinforced with steel to increase their strength without increasing their depth.

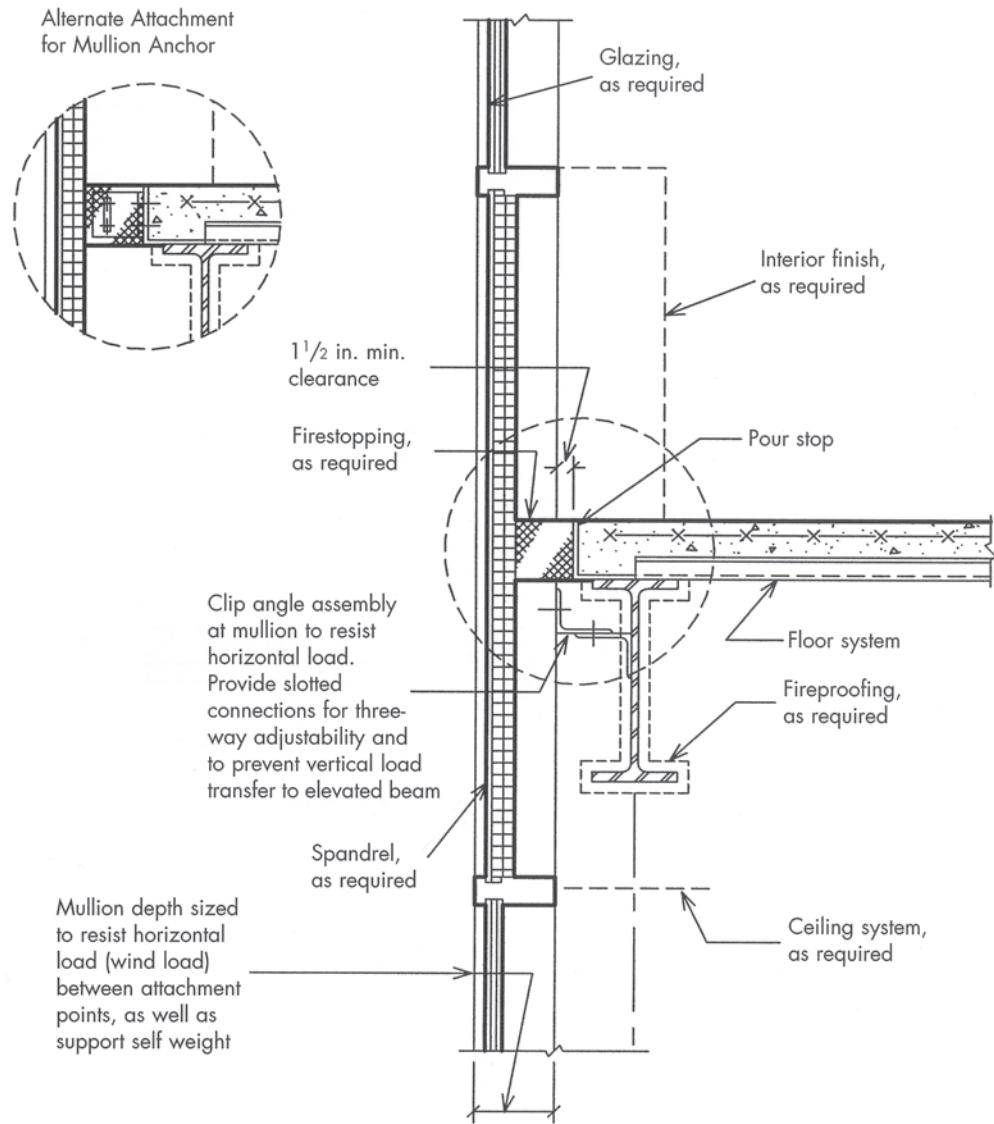

Fig. 4. Sample wall section detail for curtain wall enclosure systems.



## Floor Assemblies

Evaluating space requirements for mechanical, electrical, plumbing, and fire suppression systems can be difficult to do at the beginning of a project. Unfortunately, that is when decisions about overall building systems need to be made. Probably the most important system decision to be made is to determine the approximate space the mechanical ductwork will require within the ceiling cavity. A mechanical engineer consultant will provide the most accurate information in the early phases of the project. General locations of major ductwork or piping crossovers should be identified (Figure 5). Crossovers can be the type of problem area that require lowered ceilings and expensive beam web penetrations if sufficient space is not provided when the ceiling plenum depth is determined.

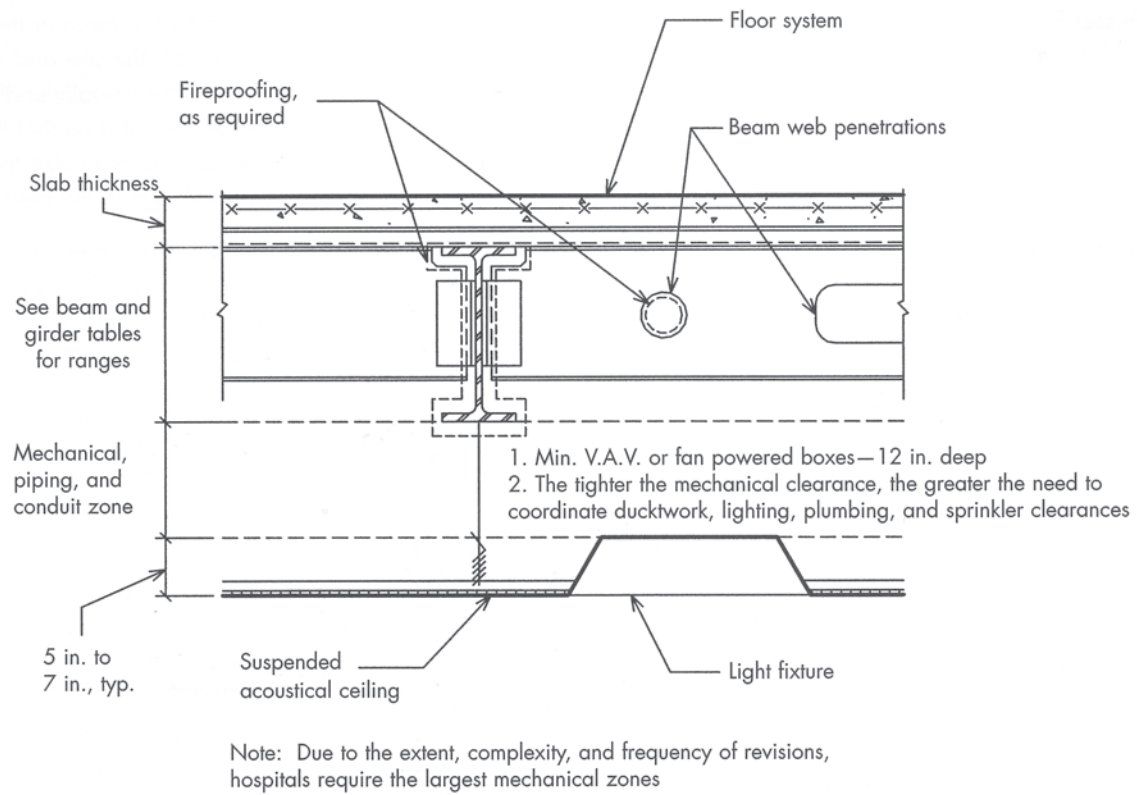

Fig. 5. Sample section detail for floor/ceiling assembly.

## Cross-Bracing Details

Buildings that incorporate cross-braces within the lateral system can be extremely economical. However, the braces themselves may conflict with ideal locations for doors or windows. In order to minimize any sort of conflict between the bracing and the doors/windows, it is important to understand exactly what shape/section the brace member is and where it is located.

It's best to bring the work lines of all connecting members together at one work point (see Figure 6). Ideally, the work lines run through the centroids of all the members. If the member is not symmetrical (for instance, an angle instead of a wide flange) then the work line is not at the mid-depths of the member because the centroid of an angle is not at the mid-depths of the member. This is essential to understand when determining whether or not a window or door frame will bypass the brace.

**Gusset Plates:** Fabricators produce gusset plates in a variety of sizes and shapes. The force in the cross-brace and the thickness of the gusset plate will dictate a gusset plate's minimal dimensions. The degree to which the brace and gusset plate must overlap to achieve the required connection strength will determine the minimum size of the gusset plate. If the gusset plate is hidden within a wall, the size and shape of the gusset plate generally is not an issue. However, if the gusset plate is exposed, there are virtually endless possibilities for its shape.

**Work Lines:** The work line for the bracing member is located at the centroid of the bracing member but it may not necessarily be at the mid-depth of the member. This would be the case for non-symmetrical members such as WT and angle shapes. Also, the angle of the bracing member at a floor may be at a different angle from a floor above or below it. This would occur if a building had varying floor-to-floor heights.

**Bracing Members:** Bracing members can consist of virtually any structural shape. Typically, rods, single angles, double angles, WT shapes, and hollow structural sections (HSS) are used as bracing members in tension. Sometimes, wide flange shapes are used if the bracing forces are extremely large.

**Work Point:** The work point is the intersection point of the work lines. It should be noted that it is desirable, but not always necessary, for the work lines to intersect at a work point. If the work lines do not intersect at a work point, the connections must be designed for these eccentricities and you may ultimately need larger members. Please consult a structural engineer for further details in this situation.

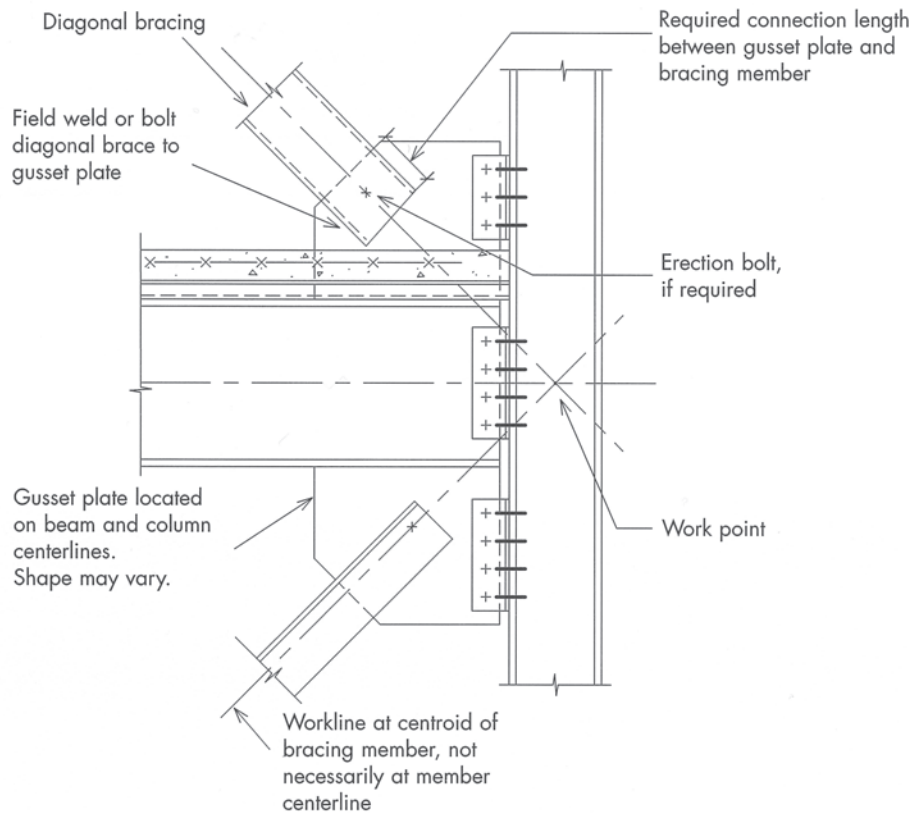

Fig. 6. Sample elevation detail for diagonal bracing.

For more information on structural detailing considerations, including additional conditions and detail downloads, please visit [aisc.org/detailingconsiderations](https://aisc.org/detailingconsiderations).





2015 AISC IDEAS<sup>2</sup> Award  
Denver Union Station, Denver  
Photo: Skidmore Owings & Merrill





# Architecturally Exposed Structural Steel

.....  
**SECTION**

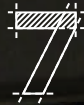

It takes a huge amount of time and energy to create an elegant structural system.

Why hide all that work when you can show it off?

Architecturally exposed structural steel puts the aesthetic focus on the structural integrity of a building. The striking visual impact of these iconic structures is possible because steel is fabricated in a nearly limitless range of shapes, tapered forms, curves, colors, and finishes.

Structural steel comprises elements that are required to support the design loads of a building and fit within the components of a structural frame, according to the AISC *Code of Standard Practice* (ANSI/AISC 303-16). For clarity, the Architecturally Exposed Structural Steel (AESS) category system is typically only applied to fabricated structural steel elements such as anchor rods, base plates, beams, bracing, canopy framing, columns, connection materials, crane stops, girders, lintels, posts, shear stud connectors, and trusses. Unfinished, reused, galvanized, or weathering steel members may all be fabricated with AESS requirements.

AESS components get the royal treatment during fabrication, shipment, and erection to avoid blemishes and unwanted surface appearance. Workers take extra care when handling the steel and removing temporary braces or fixtures. For some categories, all backing and runoff tabs are removed, and welds are ground smooth. Oil, grease, dirt, and loose mill must also be removed from basic, unpainted steel for an attractive, striking finish.

AESS can fall within the following five categories:

- AESS 1: Basic Elements
- AESS 2: Feature Elements Not in Close View
- AESS 3: Feature Elements in Close View
- AESS 4: Showcase Elements
- AESS C: Custom Elements





rd  
ove  
e

Ashland/63rd Due  
54th/Cermak 4 min

Elevator

EXIT  
Linden

Kimball  
Board here

Finch Street



Courtesy of CAST CONNEX, doublespace photography



The Queen Richmond Centre West in Toronto features massive cast elements designated as AESS. Selection of the appropriate AESS Category should consider not only viewing distance but also the coating system to be implemented. An intumescent coating has been applied to the steel.

## AESS CATEGORY MATRIX

CATEGORY		AESS C	AESS 4	AESS 3	AESS 2	AESS 1	SSS
I.D.	CHARACTERISTICS	CUSTOM ELEMENTS	SHOWCASE ELEMENTS	FEATURE ELEMENTS IN CLOSE VIEW	FEATURE ELEMENTS NOT IN CLOSE VIEW	BASIC ELEMENTS	STANDARD STRUCTURAL STEEL
1.1	Surface preparation to SSPC-SP 6		x	x	x	x	
1.2	Sharp edges ground smooth		x	x	x	x	
1.3	Continuous weld appearance		x	x	x	x	
1.4	Standard structural bolts		x	x	x	x	
1.5	Weld spatters removed		x	x	x	x	
2.1	Visual Samples		x	x	optional		
2.2	One-half standard fabrication tolerances		x	x	x		
2.3	Fabrication marks not apparent		x	x	x		
2.4	Welds uniform and smooth		x	x	x		
3.1	Mill marks removed		x	x			
3.2	Butt and plug welds ground smooth and filled		x	x			
3.3	HSS weld seam oriented for reduced visibility		x	x			
3.4	Cross-sectional abutting surface aligned		x	x			
3.5	Joint gap tolerances minimized		x	x			
3.6	All welded connections		optional	optional			
4.1	HSS seam not apparent		x				
4.2	Welds contoured and blended		x				
4.3	Surfaces filled and sanded		x				
4.4	Weld show-through minimized		x				
C.1							

Table 10.1 found in the 2022 *Code of Standard Practice for Steel Buildings and Bridges* (ANSI/AISC 303-22).



### AESS 1

- Edges ground smooth
- Continuous weld appearance
- Weld spatters removed



### AESS 2

- Uniform/smooth welds
- Fabrication marks not apparent
- One-half standard fabrication tolerances





### AESS 3

- Mill marks removed
- Butt and plug welds ground smooth and filled
- HSS seams oriented for reduced visibility
- Joint gap tolerances minimized



### AESS 4

- Weld-show through minimized
- Surfaces filled and sanded
- HSS seams not apparent
- Welds contoured and blended



## Different Viewing Levels, Different AESS Levels

Spaces like multilevel concourses provide the possibility for multiple AESS categories all in a single space and all visible at once. Kansas City's Sprint Center was built before the current AESS categories were implemented, but in looking at the below photo of the space, you can see where various categories could have been implemented. With any area employing multiple categories, the architect should provide clear notes as to where each category should be used and coordinate this documentation with the structural engineer's drawings and specifications.

The decision to architecturally expose structural steel can add significant value to a building, but coordination is essential. All parties on a project—the owners, architects, engineers, general contractors, fabricators, detailers, and erectors—must have the same level of expectations to achieve the best end result for a project. The five AESS categories all require a high degree of evaluation and coordination in order to meet project expectations within budget and schedule.

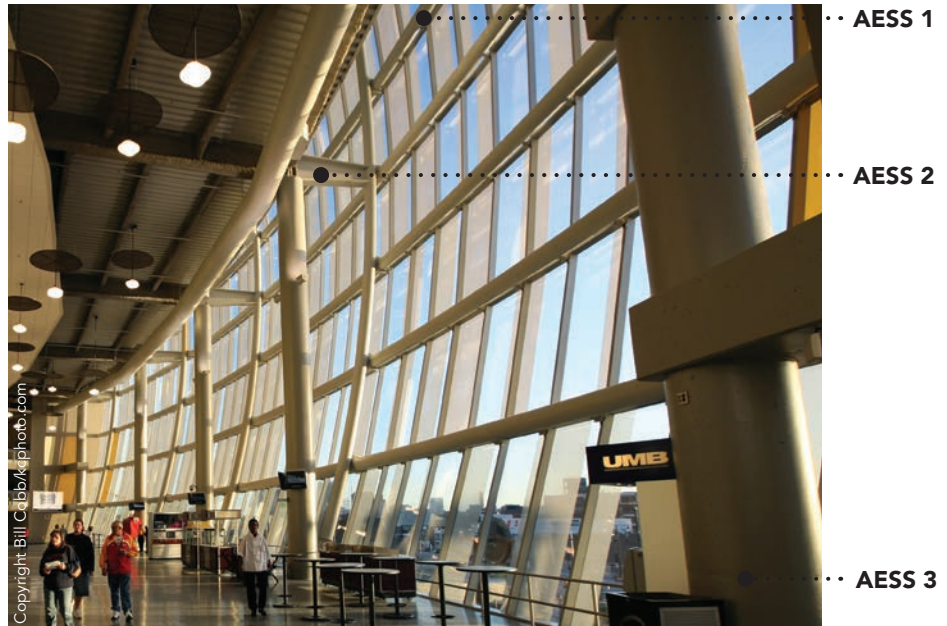

When planning to use AESS, it is important to consider the following factors:

- Member Visibility
- Viewing Distance
- Location
- Lighting
- Coatings
- Style
- Adjacency

Visit [aisc.org/aess](https://aisc.org/aess)  
for additional information.

DESIGNING WITH  
**STRUCTURAL**

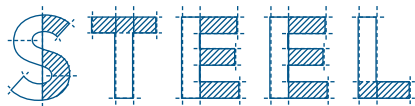

A GUIDE FOR ARCHITECTS  
[aisc.org/architectsguide](https://aisc.org/architectsguide)

1

**WHY STEEL**

[aisc.org/why-steel](https://aisc.org/why-steel)

2

**ENGINEERING BASICS**

[aisc.org/engineeringbasics](https://aisc.org/engineeringbasics)

3

**FINISHES, COATINGS, AND  
FIRE PROTECTION**

[aisc.org/fireprotection](https://aisc.org/fireprotection)

4

**SOUND ISOLATION AND  
NOISE CONTROL**

[aisc.org/soundisolation](https://aisc.org/soundisolation)

5

**SUSTAINABILITY AND RESILIENCE**

[aisc.org/sustainability](https://aisc.org/sustainability)

6

**DETAILING CONSIDERATIONS**

[aisc.org/detailingconsiderations](https://aisc.org/detailingconsiderations)

7

**ARCHITECTURALLY EXPOSED  
STRUCTURAL STEEL**

[aisc.org/aess](https://aisc.org/aess)

8

**PRELIMINARY BEAM, GIRDER AND  
COLUMN SIZE TABLES**

[aisc.org/architectsguide](https://aisc.org/architectsguide)

This chapter is available online and will help you approximate column sizes and floor and roof system depths at early stages of a project before a structural engineer is engaged.



