

# STEEL PLATE AVAILABILITY FOR HIGHWAY BRIDGES

BY CHRISTOPHER GARRELL, P.E., LEED AP

An overview of plate sizes commonly produced by domestic mills.

**THE LENGTH AVAILABILITY** for the various plate widths and thicknesses is a very common question engineers have when designing highway structures. Understanding availability of plate material while performing design iterations will ensure that the material used can be sourced from all steel mills and result in better economy for the overall bridge superstructure.

The information listed below is not intended to be an all-encompassing summary of available plates that a mill may be able to produce. It is instead intended to provide a look at plate availability across the steel mills within the United States by width, thickness and length, as shown in Figure 1. Other widths, thicknesses and lengths may be available from one or more of these producers. In cases where a dimension is not shown, one should consult the steel mill or a local steel bridge fabricator. For specific contact information, please contact your local

NSBA Regional Director (see sidebar). Alternatively, the AISC Steel Solutions Center can assist you by phone at 866.ASK.AISC and online at [www.aisc.org/askaisc](http://www.aisc.org/askaisc).

The tables that follow outline availability of A709-50 and A709-50W for non-fracture critical applications only. All units are in inches unless otherwise specified.

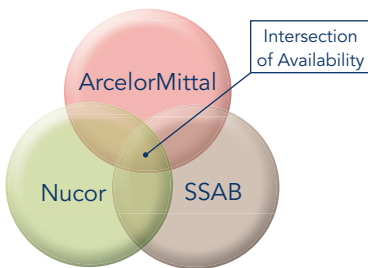

▲ Fig. 1: The rationalization of plate availability.

## Availability and Relative Cost

Steel plate producers in the United States are ArcelorMittal, Nucor and SSAB. Geographically, most steel plate mills are located within the eastern third of the United States as shown in Figure 2. Despite their location, many plate providers will choose to equalize on freight or meet a competitive price depending on their target markets.

## Usable Area

The source plate from which each component of a steel plate girder is cut and fabricated is referred to as the “mother” plate. Given the variability of plate squareness and the thickness of each cut, the net usable area of a mother plate is reduced. For example, consider the haunched girder section shown in Figure 3.

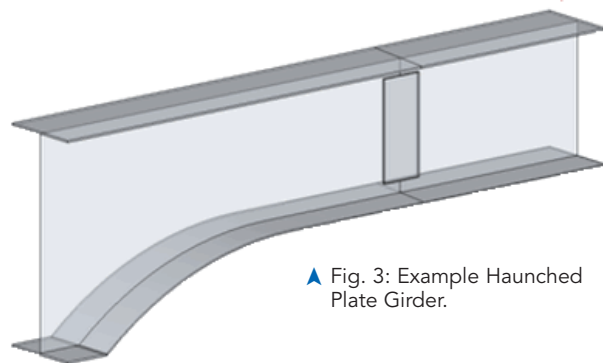

▲ Fig. 3: Example Haunched Plate Girder.

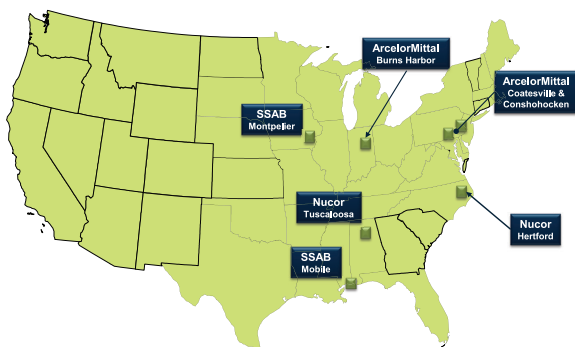

▲ Fig. 2: Plate mill locations in the United States.

**Christopher M. Garrell, P.E., LEED AP**, is Southeast Regional Director with NSBA.



The depth of the haunched web is controlled by the width availability of steel plate and also the material loss due to the cutting and squaring process (Figure 4). With respect to the flanges, a fabricator will optimize the layout of the flanges in order to maximize the number that can be obtained from a single width of plate (Figure 5). However, similar to the web, the net available area is reduced by the material lost to squaring the plate and  $n-1$  cuts (where  $n$  represents the number of flange plates that can be cut from a single mother plate). Similar to a haunch, the amount of camber a girder has also affects the net usable area of a plate.

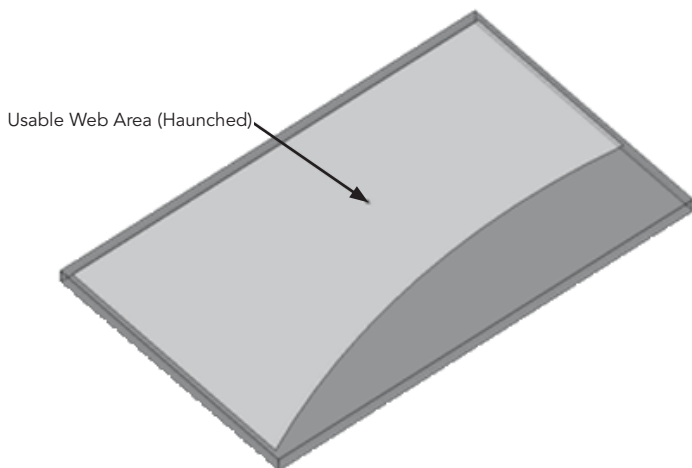

▲ Fig. 4: Usable plate area for haunched web.

▼ Fig. 5: Usable plate area for flanges.

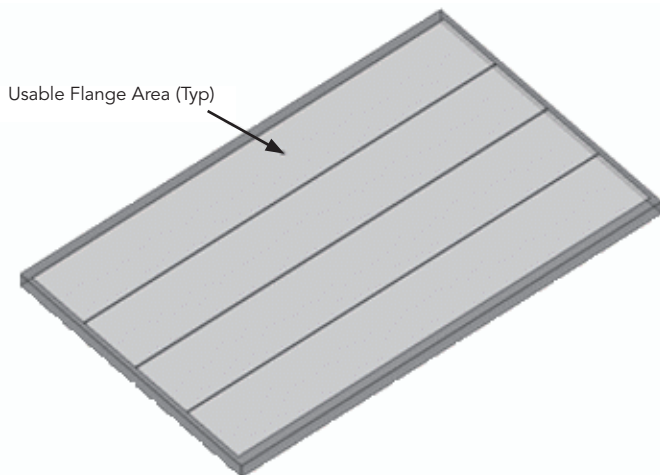

While it is not entirely necessary for engineers to include optimization of plate usage into their design process, it is important to understand how design decisions may affect the size and number of plates purchased by a fabricator to accommodate the design. At a minimum, an engineer should be conscious of how chosen sizes compare to the length and width boundaries of available steel plate, as an inch may force a fabricator to the next larger available plate size. In turn, this may increase material waste and also limit availability. For reference, Table 1 summarizes approximate material loss due to the fabrication process. Note that this can vary from fabricator to fabricator, and can be dependent on their capabilities and equipment.

	Width	Length	Notes
Web Plate	1"– 4"	1"– 6"	Material loss will increase if web is haunched or cambered.
Flange Plate	1"– 4" total plus an additional ¼" per burn	1"– 6"	A fabricator may choose to increase flange widths specified by the engineer from ¼"– ¾".

**Table 1**

Approximate material loss due to squaring and cutting during fabrication.

### A709-50 and A709-50W (Non-FC) Availability

The plate availability for ArcelorMittal, Nucor and SSAB was compiled so that the common widths and thicknesses could be tabularized. The goal of this process is to obtain steel plate thicknesses, widths and lengths that are available from all three steel plate mills. The following sections summarize the availability of A709-50 and A709-50W non-fracture critical materials, which are appropriate for the majority of the steel highway bridges being designed. As stated previously, while the capability of some steel mills exceeds what is shown, the purpose is to only summarize sizes that are available from three mills.

#### Thickness Availability

For the steel mills with information available at the time of printing, thicknesses range from 3/16 in. through 4 in.; note that the AASHTO LRFD *Bridge Design Specification* limits the thickness of material used for structural applications to 4 in. Available thicknesses are indicated by an "X" in a cell in Table 2.

#### Width Availability

Similarly, widths from all of the surveyed steel mills were tabularized to compare availability. A range from 48 in. through 138 in. is shown in Table 3. While

	ArcelorMittal	Nucor	SSAB
3/16	X		X
1/4	X		X
5/16	X	X	X
3/8	X	X	X
7/16	X	X	X
1/2	X	X	X
9/16	X	X	X
5/8	X	X	X
11/16	X	X	X
3/4	X	X	X
13/16	X	X	X
7/8	X	X	X
1	X	X	X
1 1/8	X	X	X
1 1/4	X	X	X
1 1/2	X	X	X
1 3/4	X	X	X
2	X	X	X
2 1/4	X	X	X
2 1/2	X	X	X
2 3/4	X	X	X
3	X	X	X
3 1/4	X		
3 1/2	X		
3 3/4	X		
4	X		

► **Table 2**  
Plate thickness availability by steel mill (in inches).

wider plate is available, the number of steel mills that can produce it decreases to a single provider. Available widths are indicated by an “x” in a cell in Table 3 below.

Standard industry widths are 72 in., 96 in. and 120 in. Outside these standard widths, the ability for a mill to supply the plate may become a consideration. When possible, consolidation will be performed

	ArcelorMittal	Nucor	SSAB
48	X		
54	X		
60	X		
66	X		
72	X	X	X
75	X	X	X
78	X	X	X
81	X	X	X
84	X	X	X
87	X		X
90	X	X	X
93	X	X	X
94	X	X	X
95	X	X	X
96	X	X	X
99	X	X	X
102	X	X	X
108	X	X	X
111	X	X	X
114	X	X	X
117	X	X	X
120	X	X	X
123	X	X	
126	X		
132	X		
138	X		

**Table 3**

Plate width availability by steel mill (in inches).

to minimize the number of non-standard widths, which will make steel more economical. Otherwise, a special heat sequence, which can equate to a minimum order size, may be necessary to provide plate outside the standard industry widths.

### Thickness, Width and Length Charts

The availability of different steel plate thicknesses and widths is important when making choices for plate girder cross sections;

however the piece lengths and locations of splices will be affected by the length of plate that steel mills can provide. Maximum plate length from a steel mill is a function of both plate width and thickness (Table 4).

To ensure the maximum availability, the table below was developed around cases where the thicknesses and widths are available from all four steel mills. The associated lengths for each mill at each common thickness and width were then reviewed. The minimum length for the group was then used to create Table 4. While in some instances, mills can produce longer pieces, the length values shown below ensure that if one chooses from this table, a fabricator can obtain the plate from ArcelorMittal, Nucor and SSAB.

### Closing

This distillation of steel plate availability may help ease part of the process of

designing steel plate girder highway bridges. Further information regarding best practices can be found in the AASHTO/NSBA Steel Bridge Collaboration document “Guidelines for Design for Constructability”; this and other similar documents can be found on the NSBA website, [www.steelbridges.org](http://www.steelbridges.org), under AASHTO/NSBA Steel Bridge Collaboration Standards.

Special thanks to James Barber, regional sales and product development manager, SSAB Americas; Michael Engstrom, technical marketing director, Nucor-Yamato Steel; and Phil Bischof, plate product manager, Nucor, for their assistance in collecting plate availability. Additional thanks to Alex Wilson of ArcelorMittal for his assistance. MSC

	Plate Width								
	72	78	84	90	96	102	108	114	120
3/8	972	972	972	972	972	972	972	972	750
1/2	972	972	972	972	972	972	972	972	750
9/16	972	972	972	972	972	972	972	972	972
5/8	972	972	972	972	972	972	972	972	972
3/4	1,030	1,030	1,030	1,030	1,030	1,030	1,030	1,030	1,030
7/8	1,030	1,030	1,030	1,030	1,030	1,030	1,007	954	907
1	1,030	1,030	1,030	1,030	992	933	882	835	793
1 1/4	1,030	1,030	907	846	793	747	705	668	635
1 1/2	1,030	1,030	756	705	661	622	588	557	529
1 3/4	1,030	1,030	648	604	567	533	504	477	453
2	937	937	567	529	496	467	441	418	397
2 1/4	833	833	504	470	441	415	392	371	353
2 1/2	749	749	453	423	397	373	353	334	317
2 3/4	681	681	412	385	361	339	321	304	288
3	624	624	378	353	331	311	294	278	264

**Table 4** Composite plate chart: Maximum length (in inches) for given plate thickness and width.

#### NSBA’s Regional Resources

The National Steel Bridge Alliance’s Regional Directors are the primary liaisons between NSBA and the bridge design and construction community. They assist fabricators, designers, and owners in making the best bridge design selections possible. In addition, NSBA regional directors provide steel superstructure technical assistance and technical reviews at various stages of drawing completion. To contact your NSBA regional director, please see the list to the right.

#### NSBA Managing Director

William F. McEleney, Cranston, R.I.  
[mceleney@steelbridges.org](mailto:mceleney@steelbridges.org)

#### Regional Director

Calvin R. Schrage, Lincoln, Neb.  
[schrage@steelbridges.org](mailto:schrage@steelbridges.org)

#### Regional Director

Christopher M. Garrell, P.E., LEED AP  
Philadelphia, Pa.  
[garrell@steelbridges.org](mailto:garrell@steelbridges.org)

#### Regional Director

Jeff Carlson, P.E., Denver, Co.  
[carlson@steelbridges.org](mailto:carlson@steelbridges.org)



**LRFD SIMON**  
SOFTWARE SOLUTION FOR PRELIMINARY  
BRIDGE DESIGN

# Design + analyze steel plate and tub girders even faster.

Register for your free download at [www.steelbridges.org/softwareregistration](http://www.steelbridges.org/softwareregistration)



- **Easy Input**

Manage your design parameters with ease using SIMON's new graphical user interface

- **AASHTO 5th Edition**

SIMON now uses the AASHTO 5th Edition LRFD Bridge Design Specification

- **Fast & Flexible**

Analyze and design single and multiple span steel plate and tub girders extremely quickly

- **Takeoffs & Cost Estimates**

SIMON provides quick and accurate material takeoffs as well as the ability to provide comparative cost estimation based on user input

- **Customizable Output**

Given the nature of XML, SIMON's analysis output can be displayed in many formats including Microsoft Word, PDF, and multiple web browsers

## NSBA's Steel Bridge Design Also Suite Contains

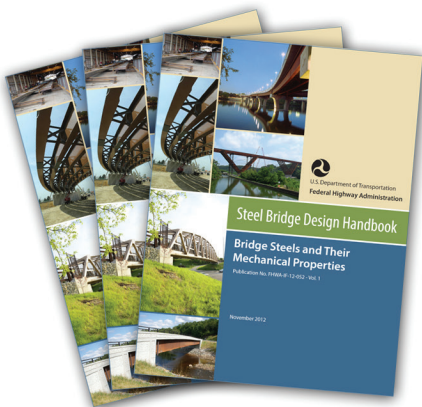

**Steel Bridge  
Design Handbook**



**NSBASPLICE**  
SOFTWARE SOLUTION FOR SPLICE DESIGN

**Splice Design  
Software**

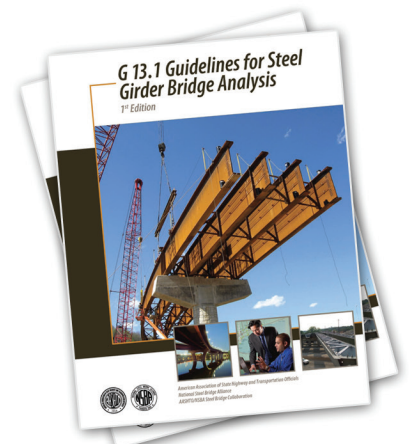

**AASHTO/NSBA  
Collaboration  
Documents**

Register and download the entire suite at [www.steelbridges.org/softwareregistration](http://www.steelbridges.org/softwareregistration)